

Series One™ Junior Programmable Controller

User's Manual

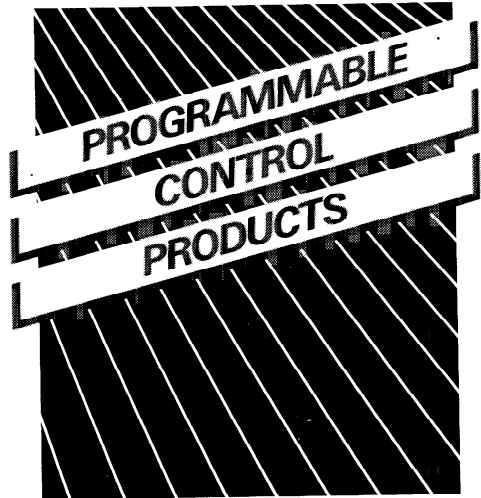

GE Fanuc Automation

Series One™ Junior Programmable Controller

User's Manual

ATTENTION

This Product has not been reviewed for application in compliance with the European Machinery Directive 89/392/EEC. Machine Builders that elect to use these products on machines to be installed within the European Union are responsible for determining and implementing special measures necessary for compliance with the Machinery Directive.

ATTENTION

La possibilité d'utiliser ce produit sur une machine devant être conforme à la directive européenne 89/392/EEC n'a pas été contrôlée. En cas d'utilisation de ce produit sur une machine installée dans l'Union Européenne, le constructeur de la machine est responsable de la détermination et de l'implémentation des mesures nécessaires à la mise en conformité de la machine par rapport à la directive européenne 89/392/EEC.

ACHTUNG

Dieses Produkt wurde nicht auf den Einsatz in Maschinen gemäß der Europäischen Maschinen Richtlinie 89/392/EEC überprüft. Maschinenhersteller, die dieses Produkt in Maschinen, welche in Ländern der Europäischen Gemeinschaft installiert werden, einsetzen möchten, sind verpflichtet alle notwendigen Maßnahmen zu ergreifen, daß die o.g. Maschinen-Richtlinien erfüllt werden.

ATTENZIONE

La possibilità di utilizzare questo prodotto su una macchina che deve essere conforme alla direttiva europea 89/392/EEC, non è stata verificata. In caso di utilizzo di questo prodotto su una macchina all'interno dell'Unione Europea, il costruttore della macchina è responsabile della determinazione e della realizzazione delle misure necessarie a soddisfare la conformità della macchina alla direttiva europea 89/392/EEC.

ATENCION

Este producto no ha sido revisado, para aplicaciones en maquinaria de acuerdo con la normativa 89/392/EEC. En caso de la utilización de este producto en una máquina instalada dentro de la Comunidad Europea, el constructor de la máquina será responsable de la determinación y la aplicación de las medidas necesarias para que la máquina cumpla con dicha normativa.

GFZ-0095

January 1995

GE Fanuc Automation

MARCH 1987

GEK-90503A

WARNING, CAUTION, AND NOTES AS USED IN THIS PUBLICATION

WARNING

Warning notices are used in this publication to emphasize that hazardous voltages, currents, temperatures, or other conditions that could cause personal injury exist in this equipment or may be associated with its use.

In situations where inattention could cause either personal injury or damage to equipment, a Warning notice is used.

CAUTION

Caution notices are used where equipment might be damaged if care is not taken.

NOTE

Notes merely call attention to information that is especially significant to understanding and operating the equipment.

This document is based on information available at the time of its publication. While efforts have been made to be accurate, the information contained herein does not purport to cover all details or variations in hardware and software, nor to provide for every possible contingency in connection with installation, operation, and maintenance. Features may be described herein which are not present in all hardware and software systems. GE Fanuc Automation assumes no obligation of notice to holders of this document with respect to changes subsequently made.

GE Fanuc Automation makes no representation or warranty, expressed, implied, or statutory with respect to, and assumes no responsibility for the accuracy, completeness, sufficiency, or usefulness of the information contained herein. No warranties of merchantability of fitness for purpose shall apply.

P R E F A C E

The purpose of this manual is to provide the information required by the user to install, program and implement the Series One Junior Programmable Controller (PC) into a control system. The Series One Junior PC is another offering in the growing family of Series One PCs. The Series One Junior PC can replace as few as 4 relays, and is designed for control applications with 4 to 60 relays.

Chapter 1 is an introduction to the Series One Junior PC, with emphasis on its features and capabilities. A summary of terms common to PCs is provided at the end of this chapter, as an aid to first-time PC users.

Chapter 2 provides a detailed description of the hardware components of the PC. This chapter provides an understanding of the components of a Series One Junior PC system and how they are related to the overall system.

Chapter 3 provides the specifications and instructions required for installation of your Series One Junior PC system.

Chapter 4 describes the operation of the Series One Junior PC, including the features and functions of the programmer used for entering new programs, editing existing programs, monitoring the status of inputs or outputs, and displaying timer or counter accumulated values. The last part of this chapter describes operation of peripheral devices which may be used with a Series One Junior PC. These peripherals include an audio tape recorder for recording your program after it has been entered, in order to have a permanent record of that program; PROM Writers, which allow a non-volatile means of program storage within the PC, and printers for documenting your programs.

Chapter 5 provides the basic information required in order to develop, enter, and implement your programs. A description of each function is provided, including examples of using each function, and step-by-step entry of sample programs.

Chapter 6 is a guide to the capabilities of the input and output (I/O) circuitry and their physical connections to field devices, in both Series One Junior basic units and I/O modules contained in an expansion rack. UL listed products are included.

Chapter 7 is a guide to maintenance of your system, should it be needed. Reliability of the Series One Junior PC is excellent and other than changing the Lithium back-up battery, as required, there should be little maintenance required of your PC.

Chapter 8 provides several typical applications using the Series One Junior PC. This chapter should be especially helpful to first-time users of a programmable controller.

Should further information be required, contact your salesperson or GE Fanuc Automation North America, Inc., P.O. Box 8106, Charlottesville, Virginia, 22906.

Henry A. Konat
Senior Technical Writer

The Series One Junior has been tested and found to meet or exceed the requirements of FCC Rule, Part 15, Subpart J. The FCC requires that the following note be published.

NOTE

This equipment generates, uses, and can radiate radio frequency energy and if not installed and used in accordance with the instruction manual, may cause interference to radio communications. It has been tested and found to comply with the limits of a Class A computing device pursuant to Subpart J of Part 15 of FCC Rules, which are designed to provide reasonable protection against such interference when operated in a commercial environment. Operation of this equipment in a residential area is likely to cause interference in which case the user at his own expense will be required to take whatever measures may be required to correct the interference.

TABLE OF CONTENTS

Chapter 1 Introduction

History of the Programmable Controller	1-1
Advantages Over Other Control Devices	1-1
Series One Junior™ Programmable Controller	1-1
General Specifications for the Series One Junior PC	1-3
Internal Functions	1-4
Programmable Controller Concepts	1-5
Programming the Series One Junior PC	1-6
Function of the Central Processor Unit	1-6
Types of Memory Used for Program Storage	1-6
Function of the Input/Output Circuitry	1-7
System Planning	1-7
Communicating With Other Devices	1-7
PC Terminology	1-8

Chapter 2 Physical Equipment Configuration

Introduction	2-1
Equipment Configuration	2-1
Front and Side Panel Features	2-3
Status Indicator Lights	2-3
Front Panel Connector	2-5
I/O Status Display	2-5
Field Wiring Terminals	2-5
Top Terminals	2-5
Bottom Terminals	2-6
Side Panel Connector	2-6
Battery Compartment Access Cover	2-6
PROM Socket	2-6
Programmer Tape Port	2-7
Programmer Mount Assembly	2-8
I/O Expansion Requirements	2-8
I/O Expansion Rack References	2-8
I/O Expansion Module Faceplate	2-10
Expansion Racks	2-11
Rack Mount Brackets	2-12
I/O Module Placement in Racks	2-12
Expansion Rack Heat Dissipation	2-12
Routing of Field Wiring	2-12
Data Communications Unit	2-13
Peripheral Devices Supporting Series One Junior	2-13
Printer Interface Unit	2-13
PROM Writer Unit	2-14
I/O Expansion Units	2-15
I/O Expansion Unit Features	2-16

Chapter 3 Installation

Introduction	3-1
Installation Specifications	3-1
Mounting Dimensions	3-2
Installation Instructions	3-3
Mounting the Basic Unit	3-3
Mounting an Expansion Rack	3-3
Power Connections	3-5
Series One Junior	3-5
Expansion rack	3-5
Inserting I/O Modules Into an Expansion rack	3-7
I/O Field Wiring	3-7
Programmer (Hand-Held)	3-8
Programmer Mount Assembly	3-9
Power Supply Limitations for Expansion Racks	3-10
Installation of Expansion Units	3-13
Remote Mounting of Timer Counter Setpoint Unit	3-14

Chapter 4 Operation

Introduction	4-1
Programmer	4-1
Programmer Features	4-2
Mode Switch	4-2
Address/Data Display	4-2
Status Display	4-2
Logic Display	4-3
Logic Keys	4-3
Editing Keys	4-5
Shifted Functions	4-7
Program Checking and Error Codes	4-8
Operation Sequences	4-12
Monitor CPU Logic	4-13
Search CPU Logic	4-14
Alter One Logic Element	4-14
Delete One logic Element	4-15
Clear All Memory	4-15
Insert One Logic Element	4-15
Monitor I/O Status	4-16
Monitor Timer or Counter Status	4-17
Display a Specific Address	4-17
Forcing I/O References	4-18
Operation with Peripheral Devices	4-19
Tape Recorder Operation	4-19
Recording a Program	4-19
Verifying a Program	4-20
Loading a Program	4-22

Chapter 4 (Continued)

Printer Interface Unit	4-23
Hardware Description	4-24
Hardware Features	4-25
80/132 Column Selection Switch	4-26
External Power Supply Connector	4-26
Power Supply Select Switch	4-26
Sequence of Operation	4-26
Power-Up Sequence	4-26
Program Transfer From PC to Printer Interface Unit	4-27
Selection of Printout Format and Type of PC	4-27
Start Printer Operation	4-27
Printing Error Messages During Ladder Diagram Listing	4-27
Printing Error Messages During Boolean Listing	4-28
Cross Reference Printout	4-28
Expanded Print Format	4-29
Printout Annotation Explanation	4-29
Sample Printout	4-30
PROM Writer Unit	4-34
Front Panel Features	4-35
Sequence of Operation	4-36
External Power Supply Connector	4-37
Power Supply Select Switch	4-37
Timer/Counter Setpoint Unit	4-37

Chapter 5 Programming

Introduction	5-1
Programming References	5-1
Input/Output References	5-2
Use of Internal Coils	5-2
Use of the Special Purpose Coils	5-2
Shift Register References	5-2
Timer and Counter References	5-2
Flexibility in Using References	5-3
CPU Operating Principles	5-3
CPU Scanning	5-3
Programming the Series One Junior	5-4
Programmer Keys	5-5
Basic Ladder Diagram Format	5-6
Concept of Power Flow	5-6
Unlimited References	5-7
Developing the Program	5-7
Programming Functions	5-7
How to Begin Programming	5-8
Entering a Rung With Series Contacts	5-8
Entering the Clear All Memory Sequence	5-9
Entering a Rung With Parallel Contacts	5-9
Entering a Simple Timer Rung	5-10

Chapter 5 (Continued)	
Basic Relay Logic (Motor Starter)	5-10
Motor Starter Logic Description	5-11
Normally Closed Input	5-12
Connecting Series and Parallel Groups of Logic	5-13
Use of Retentive Coils as Latches	5-15
Programming a Latched Coil	5-15
Master Control Relay Function Description	5-16
Programming a Master Control Relay Function	5-17
Multiple Master Control Relay Functions	5-17
Disabling of Outputs	5-18
Timer and Counter Functional Description	5-20
Programming Timers	5-20
Programming Counters	5-22
Extending the Timer and Counter Range	5-24
High Speed Counter, (Built-In)	5-25
Count Enable Input	5-25
Reset Input	5-25
High Speed Counter Reference	5-25
Programming the High Speed Counter	5-25
High Speed Counter Operation	5-26
Recommendations for Programming Preset Values	5-27
Sequencers	5-29
Shift Registers	5-32
Shift Register References	5-33
Shift Register Operation	5-33
Forcing I/O References	5-36
Chapter 6 I/O Capabilities	
Introduction	6-1
I/O Reference Assignment	6-1
Field Wiring to Basic Units	6-1
Top Terminals	6-1
Bottom Terminals	6-1
Field Wiring to I/O Modules	6-2
16 Circuit I/O Modules	6-3
Series One Junior Catalog Numbers	6-4
I/O Wiring	6-5
115 V ac Input, 115/230 V ac Output — Basic Unit	6-5
Bleeder Resistor Calculation	6-7
24 V dc Sink Input, 115/230 V ac Output Basic Unit	6-9
24 V dc Sink Input/24 V dc Sink Output — Basic Unit	6-13
24 V dc Sink Input/Relay Output — Basic Unit	6-17
24 V dc Source Input/Relay Output — Basic Unit	6-21
115 V ac Input Module	6-25
230 V ac Input Module	6-27
115 V ac Isolated Input Module	6-29
24 V dc Sink Input (8 Circuits) Module	6-31
24 V dc Sink Input (16 Circuits) Module	6-33
24 V ac/dc Source Input Module	6-35
115/230 V ac Output Module	6-37

Chapter 6 (Continued)

115/230 V ac Isolated Output Module	6-39
24 V dc Sink Output (8 Circuits) Module	6-41
24 V dc Sink Output (16 circuits) Module	6-43
24 V dc 2 Amp Sink Output Module	6-45
24 V dc 2 Amp Sink/Source Output Module	6-47
24 V dc Source Output Module	6-49
Relay Output Module	6-51
24 V dc Input/Output (4 In/4 Out) Module	6-53
24 V dc Input/Relay Output (4 In/4 Out) Module	6-55
Fast Response I/O Module	6-58
I/O Simulator	6-64
24 V dc Sink Input/Output, Expansion Unit	6-65
24 V dc Sink Input/Relay Output, Expansion Unit	6-67
24 V dc Source Input/Relay Output, Expansion Unit	6-70
Analog Input Module	6-73
Analog Output Module	6-78
UL Listed Products	6-81
115 V ac Input/115 V ac Output, Basic Unit (UL)	6-82
115 V ac Input/115 V ac Output, Expansion Unit (UL)	6-86
5-Slot Rack (UL)	6-89
115 V ac Input Module (UL)	6-90
Relay Output Module (UL)	6-92
115 V ac Output Module (UL)	6-94
24 V dc Sink Load Input w/Removable Terminal Board	6-96
24 V ac/dc Source Input w/Removable Terminal Board	6-98
24 V dc Sink Output w/Removable Terminal Board	6-100
24 V dc Source Output w/Removable Terminal Board	6-102
Relay Output w/Removable Terminal Board	6-104

Chapter 7 Maintenance

Introduction	7-1
Troubleshooting Aids	7-1
Basic Troubleshooting Procedure	7-1
General Troubleshooting Procedure	7-2
Replacement of Components	7-3
Replacing a Basic Unit	7-3
Replacing Expansion Rack I/O Modules	7-4
Replacing an Expansion Rack	7-5
Replacing the Lithium Battery	7-5
Fusing Information	7-7
Replacing a Fuse	7-8

Chapter 8 Applications

Application 1 — One-Shots	8-1
Application 2 — Flip Flop	8-2
Application 3 — Event/Time Drum	8-3
Application 4 — Cascaded Counters	8-7
Application 5 — Coil 374, Power-Up One-Shot	8-8

Application 6 — Coil 375, 10 Hz Clock	8-9
Example 1 — Cumulative Timer	8-9
Example 2 — Time of Day Clock	8-9
Application 7 — Start/Stop Circuit	8-12
Application 8 — Using AND•STR, OR•STR Instructions	8-13

Appendix A

Glossary of Terms	A-1
-------------------	-----

Appendix B

Other Programmable Controllers	B-1
Series One™	B-1
Series Three™	B-2
Series Six™	B-3

Index	I-i to I-x
--------------	------------

FIGURES

Chapter 1

1-1	Typical Series One Junior Basic Unit	1-2
1-2	Typical Series One Junior PC System Configuration	1-3
1-3	PC General Block Diagram	1-5

Chapter 2

2-1	Front Panel Features	2-3
2-2	Side Panel Features	2-5
2-3	PROM Orientation Into Socket	2-6
2-4	Programmer Mount Assembly	2-7
2-5	I/O Reference Per Slot Location	2-5
2-6	I/O Expansion Module	2-9
2-7	Typical Series One Racks	2-10
2-8	Expansion Rack Mounting Considerations	2-11
2-9	Data Communications Unit	2-12
2-13	Printer Interface Unit	2-13
2-14	PROM Writer Unit	2-14

Chapter 3

3-1	Mounting Dimensions, Basic Unit	3-2
3-2	Mounting dimensions for 5 and 10 Slot Racks	3-3
3-3	Recommended Expansion Rack Grounding	3-4
3-4	Power Connections	3-5
3-5	Expansion Rack Terminal Strip Location	3-6
3-6	Module Insertion Into Expansion Rack	3-7
3-7	Module Removal from Expansion rack	3-7
3-8	Pull Tab on Programmer Cable	3-9
3-9	Installation of Programmer Cable	3-9
3-10	Programmer Mount Assembly	3-10

Chapter 4

4-1	Programmer Features	4-1
4-2	Series Logic (AND)	4-4
4-3	Parallel Logic (OR)	4-4
4-4	Volume Control Range Setting	4-21
4-5	Front, Side, and Rear Views of Printer Interface Unit	4-24
4-6	Sample Ladder Diagram Printout	4-30
4-7	Sample Boolean Printout	4-31
4-8	Sample Outputs Used Table Printout	4-32
4-9	Sample Outputs Used Table Printout (Continued)	4-33
4-10	Plug-On PROM Writer Unit Features	4-34

Chapter 5

5-1	CPU Scanning Sequence	5-4
5-2	Programmer	5-5
5-3	Basic Ladder Diagram Format	5-6
5-4	Sample Relay Logic (Motor Starter)	5-11
5-5	Example of Normally Closed Inputs	5-12
5-6	AND STR and OR STR Connections	5-13
5-7	Programming the AND STR and OR STR Instructions	5-14
5-8	Sample Latching Logic	5-15
5-9	Master Control Relay Logic	5-17
5-10	Multiple Master Control Relay Logic	5-18
5-11	Coil Disabler Logic Example	5-19
5-12	Timer Logic Requirements	5-20
5-13	Example of Timer Logic	5-21
5-14	Counter Logic Requirements	5-22
5-15	Counter Example	5-23
5-16	Example of Extended Timers and Counters	5-24
5-17	High Speed Counter Timing Chart	5-27
5-18	High Speed Counter Program Example	5-27
5-19	Illustration of Sequencer Operation	5-28
5-20	Sequencer Example	5-29
5-21	Example of Sequencer Logic	5-30
5-22	Typical Shift Register	5-31
5-23	Example of a Shift Register	5-32
5-24	Sample Shift Register Logic	5-34

Chapter 6

6-1	Typical I/O Module	6-1
6-2	Typical I/O Module Terminal Arrangement	6-1
6-3	I/O Interface Cable Wiring List	6-3
6-4	Wiring for 115 V ac Inputs — Basic Unit	6-6
6-5	Wiring for 115 V ac Outputs — Basic Unit	6-8
6.5a	Wiring for 24 V dc Sink Inputs, IC609SJR102	6-10
6.5b	Wiring for 115 V ac Outputs, IC609SJR102	6-12
6-6	Wiring for 24 V dc Sink Inputs — Basic Unit	6-14
6-7	Wiring for 24 V dc Sink Outputs — Basic Unit	6-16
6-8	Wiring for 24 V dc Sink Inputs — Basic Unit	6-18
6-9	Wiring for Relay Outputs — Basic Unit	6-20
6-10	Wiring for 24 V dc Source Inputs — Basic Unit	6-22
6-11	Wiring for Relay Outputs — Basic Unit	6-24
6-12	Wiring for 115 V ac Inputs	6-26
6-13	Wiring for 230 V ac Inputs	6-28
6-14	Wiring for 115 V ac Isolated inputs	6-30
6-15	Wiring for 24 V dc Inputs	6-32
6-16	I/O Points Vs. Temperature Chart	6-33
6-17	Wiring for 16 Circuit, 24 V dc Sink Input Module	6-34
6-18	Wiring for 24 V ac/dc Inputs	6-36
6-19	I/O Points Vs. Temperature Chart	6-37

6-20	Wiring for 115 V ac Outputs	6-38
6-21	I/O Points Vs. Temperature Chart	6-39
6-22	Wiring for 115 V ac Isolated Outputs	6-40
6-23	I/O Points Vs. Temperature Chart	6-41
6-24	Wiring for 24 V dc Sink Outputs	6-42
6-25	I/O Points Vs. Temperature Chart	6-43
6-26	Wiring for 16 Circuit 24 V dc Sink Outputs	6-44
6-27	I/O Points Vs. Temperature Chart	6-45
6-28	Wiring for 24 V dc 2 Amp Sink Outputs	6-46
6-29	I/O Points Vs. Temperature Chart	6-47
6-30	Wiring of 24 V dc 2 Amp Sink/Source Outputs	6-48
6-31	I/O Points Vs. Temperature Chart	6-49
6-32	Wiring for 24 V dc Source Outputs	6-50
6-33	Wiring for Relay Outputs	6-52
6-34	Wiring for 24 V dc Inputs/Outputs	6-54
6-35	Typical Wiring Diagram	6-56
6-36	Sample 24 V dc Input/Relay Output Circuits	6-57
6-37	Fast Response Module Logic Diagram	6-60
6-38	Module Reference/Logic Symbol Definitions	6-62
6-39	Wiring for Fast Response I/O Module	6-63
6-40	I/O Simulator Module Faceplate	6-64
6-41	Wiring, 24 V dc Sink Inputs, Expansion Unit (IC609EXP110)	6-65
6-42	Wiring, 24 V dc Sink Outputs, Expansion Unit (IC609EXP110)	6-66
6-43	Wiring, 24 V dc Sink Inputs, Expansion Unit (IC609EXP120)	6-67
6-44	Wiring, Relay Outputs, Expansion Unit (IC609EXP120)	6-69
6-45	Wiring, 24 V dc Source Inputs, Expansion Unit (IC609EXP121)	6-70
6-46	Wiring, Relay Outputs, Expansion Unit (IC609EXP121)	6-72
6-47	Analog Input Module Faceplate	6-77
6-48	Analog Output Module Faceplate	6-80
6-49	Wiring, 115 V ac Inputs, Basic Unit (UL)	6-83
6-50	Wiring, 115 V ac Outputs, Basic Unit (UL)	6-85
6-51	Wiring, 115 V ac Inputs, Expansion Unit (UL)	6-87
6-52	Wiring, 115 V ac Outputs, Expansion Unit (UL)	6-88
6-53	UL Listed 5-Slot Rack	6-89
6-54	Wiring, 115 V ac Input Module (UL)	6-91
6-55	Wiring, Relay Output Module (UL)	6-93
6-56	Wiring, 115 V ac Output Module (UL)	6-95
6-57	I/O Points Vs. Temperature Chart	6-96
6-58	Wiring, 24 V dc Sink Load Inputs (16 Circuits)	6-97
6-59	I/O Points Vs. Temperature Chart	6-98
6-60	Wiring, 24 V ac/dc Source Load Inputs (16 Circuits)	6-99
6-61	I/O Points Vs. Temperature Chart	6-100
6-62	Wiring, 24 V dc Sink Outputs (16 Circuits)	6-101
6-63	I/O Points Vs. Temperature Chart	6-102
6-64	Wiring, 24 V dc Source Outputs (16 Circuits)	6-103
6-65	Wiring, Relay Outputs (16 Circuits)	6-105

Chapter 7

7-1	Series One Junior Troubleshooting Indicators	7-1
7-2	Battery Location	7-6

Chapter 8

8-1	Typical One-Shot Timing	8-1
8-2	Typical One-Shot Logic	8-1
8-3	Typical Flip-Flop Timing Diagram	8-2
8-4	Typical Flip-Flop Logic	8-2
8-5	Event/Time Drum Logic	8-3
8-5	Event/Time Drum Logic (Continued)	8-4
8-5	Event/Time Drum Logic (Continued)	8-5
8-5	Event/Time Drum Logic (Continued)	8-6
8-6	Sample Cascaded Counter Logic	8-7
8-7	Typical Machine or Process Power-up Inhibit Logic	8-8
8-8	Cumulative Timer	8-9
8-9	Sample 24 Hour Time Clock Logic	8-10
8-10	Time Clock Resetting	8-11
8-11	Fast Response Start/Stop Logic	8-12
8-12	Worst Case Timing Diagram	8-12
8-13	Push Down Stack Storage Locations	8-13
8-14	AND•STR/OR•STR Example 1	8-15
8-15	AND•STR/OR•STR Example 2	8-16

T A B L E S

Chapter 1

1-1	Series One Junior PC General Specifications	1-4
1-2	Internal Functions	1-5
1-3	PC Terminology	1-8

Chapter 2

2-1	Series One Junior PC Catalog Numbers	2-2
-----	--------------------------------------	-----

Chapter 3

3-1	Series One Junior PC General Specifications	3-1
3-2	Expansion Installation Specifications	3-2
3-3	Units of Load Supplied by Rack	3-11
3-4	Units of Load Used by I/O Modules	3-11

Chapter 4

4-1	Error Code Definitions	4-9
4-1	Error Code Definitions (Continued)	4-10
4-1	Error Code Definitions (Continued)	4-11
4-2	PC Operation Sequences	4-12
4-2	PC Operation Sequences (Continued)	4-13
4-4	Printer Interface Unit Specifications	4-23
4-5	Printer Requirements	4-23
4-6	Format and PC Selection	4-27
4-7	Ladder Diagram Listing Error Messages and Definitions	4-28
4-8	Boolean Listing Error Messages and Definitions	4-28

Chapter 5

5-1	Programming References	5-1
5-2	Programming Functions	5-8
5-3	Effect of Coil 376 (Output Disabler)	5-19

Chapter 6

6-1	Series One Junior PC and Series One I/O Module Catalog Numbers	6-4
6-2	Maximum Current Vs. Load Type for Relay Outputs	6-51
6-3	Maximum Current Vs. Load Type for Relay Outputs	6-56
6-4	Maximum Current Vs. Load Type for Relay Outputs	6-59
6-5	Truth Table for Output in Fast Response Mode (S5 or S7 Have Been Enabled)	6-61
6-5	Maximum Current for Load Types	6-68
6-7	Maximum Current for Load Types	6-71
6-8	Analog Input Module Specifications	6-74
6-9	I/O Point Definition	6-75
6-10	Analog Output Module Specifications	6-79
6-11	I/O Point Definition	6-80
6-12	Maximum Current for Load Types	6-104

Chapter 7

7-1	Series One Junior Fuse List	7-7
-----	-----------------------------	-----

Chapter 8

8-1	AND Y and OR Y Truth Tables	8-14
-----	-----------------------------	------

Appendix

B-1	Series One I/O Modules	B-1
B-2	Series Three PC Specifications	B-2
B-3	Series Six CPU Capacities	B-3

CHAPTER 1 INTRODUCTION

HISTORY OF THE PROGRAMMABLE CONTROLLER

In today's ever changing control environment, automation is made possible through the use of electronics. Electronics is indeed the path to future automation. The rapid development of electronic devices has made the concept of the factory with a future a reality for modern technology. The factory with a future is possible today. It can provide improved system reliability, product quality, information flow, reduced costs, efficiency, and flexibility. One of the basic building blocks of such a factory is an electronic device called a Programmable Controller. This device was first introduced in 1970 and has been refined every 4-7 years as newer electronic components such as microprocessors were made available. Today's Programmable Controllers are designed using the latest in microprocessor design and electronic circuitry which provide reliable operation in industrial applications where many hazards such as electrical noise, high temperature, unreliable AC power, and mechanical shock exist. Here is where the Programmable Controller is in its element; it is designed for the industrial environment from its conception.

ADVANTAGES OVER OTHER CONTROL DEVICES

Programmable Controllers, or PCs as they are frequently referred to, offer many advantages over other control devices such as relays, electrical timers and counters, and drum type mechanical controllers. Several advantages of a PC should be considered beyond price only when specifying and selecting any control device. These advantages typically are:

- Improved reliability
- Easier maintainability
- Smaller space required
- Programmable as system requirements change
- Less expensive than equivalent hard-wired systems
- More flexible (can perform more functions)
- Reusable

SERIES ONE JUNIOR™ PROGRAMMABLE CONTROLLER

The GE Fanuc Automation Series One Junior Programmable Controllers are a low-cost group of Programmable Controllers designed for control applications requiring 4 to 60 relays. A Series One Junior, being compact, requires only 53 square inches of mounting area, which is about the same space as four 4-pole relays. The Series One Junior PC provides a fixed number of I/O points in its compact package.

Each Series One Junior PC provides 24 I/O, which includes 15 inputs and 9 outputs. A typical Series One Junior basic unit is shown in Figure 1.1. The input terminals are located at the top of the unit and the output terminals and power source connections are located at the bottom of the unit.



Figure 1.1 TYPICAL SERIES ONE JUNIOR BASIC UNIT

The Series One Junior Programmable Controller has 700 words of CMOS RAM or optional EPROM memory for user program storage. If more than 24 I/O points are required for an application, the I/O can be expanded two ways. An I/O Expansion unit, having the same form as the basic unit, can be connected, thereby adding up to 26 I/O points. This method of expansion provides a total of up to 50 I/O points in your system. An additional 72 points is added by connecting the Series One Junior unit to an expansion rack. The expansion rack can be any of the currently available Series One 5 or 10-slot racks. Using this method allows a total of 96 I/O points. One method or the other can be used for expansion; not both.

The expansion rack can contain any combination of currently available Series One input or output ac or dc modules, with the exception of the High Speed Counter and Thumbwheel Interface modules. An added convenience is that the expansion rack can be installed up to 100 feet (30 m) from the Series One Junior. This allows the expansion rack to be located close to the machine or process being controlled. Figure 1.2 illustrates a typical Series One Junior PC system.

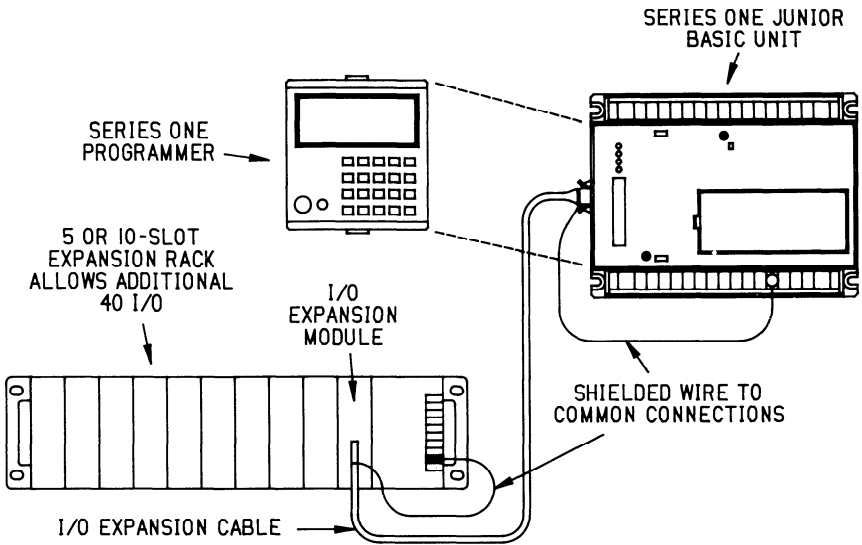

Figure 1.2 TYPICAL SERIES ONE JUNIOR PC SYSTEM CONFIGURATION

The Series One Junior uses many of the same support devices as the Series One PC, including the programmer, PROM writer, printer interface unit, and data communications unit. The programming language for the Series One Junior is the same as that used for the Series One and the same, hand-held programmer is used for entering those programs. The programmer can be installed on the basic unit, connected to the unit through a 5 foot (1.5m) cable, or it can be remotely mounted on the programmer mount assembly. Since programming is the same, an added convenience is that many programs developed on a Series One Junior can be transferred to a Series One for program execution.

An input circuit is provided (circuit 15) to count pulses up to 2000 counts per second (2 kHz), which gives the Series One Junior the added feature of having a built-in high speed counter. Another input circuit (circuit 16) is provided as a pulse reset circuit for the high speed counter. The counter has 20 preset points, which allows control of up to 20 high speed counting or sequencing events. Field wiring to the Series One Junior is made to terminals, located on the top and bottom edges of the unit.

Models of the Series One Junior are available in various combinations of voltages, such as AC Input/AC Output, DC Sink Input/DC Sink Output, DC Sink Input/Relay Output, and DC Source Input/Relay Output. UL approved models are also available.

GENERAL SPECIFICATIONS FOR THE SERIES ONE JUNIOR PC

General specifications for Series One Junior Programmable Controllers are listed in Table 1. These specifications include environmental and physical parameters which must be considered when specifying a programmable control system.

Table 1.1 SERIES ONE JUNIOR P C GENERAL SPECIFICATIONS

Operating Temperature	0° to 60 C° (32° to 140° F)
Storage Temperature	- 10° to 70° C (14° to 158° F)
Humidity (non-condensing)	5 to 95%
Required ac Power	115/230 V ac + 10%/ - 15%
Frequency	47 to 63 Hz
Maximum Load	25 volt-amps
Available dc power for user devices.	24 V dc + 10%/ - 20% (α 100 mA maximum)
Weight	4.1 lb (1850 grams)
Typical Battery Life	2 to 5 years
Shelf Life	8 to 10 years
Memory size and Type, 16-bit words	700 words CMOS or EPROM
Typical Scan Rate	12 ms for 250 words 40 ms for 700 words
Dimensions	
Basic Unit	Width 8.25" (210mm) Height 6.4" (162mm) Depth 2.2" (56mm)
Expansion Rack (5-slot)	Width 11.4" (290mm) Height 4.7" (120mm) Depth 5.4" (136mm)
(10-slot)	Width 18.9" (480mm) Height 4.9" (123mm) Depth 5.4" (136mm)

INTERNAL FUNCTIONS

The Series One Junior PC has functions other than input and output points which can be included in the user programs. These functions include internal coils, which are not available as "real world" outputs. This group of coils is available for use as control relays within the user logic. The internal coils are further defined as being either retentive or non-retentive. The retentive coils, when programmed as such, have their ON or OFF status retained during periods when the PC is not operating, such as during no-power conditions. The internal functions also include timers and counters, shift registers, sequencers, and a built-in high speed counter. The internal functions built into the PC are listed below in Table 1.2.

Table 1.2 INTERNAL FUNCTIONS

Number of I/O Points	
Basic Unit	24
With Expansion Rack	96 (total I/O)
With no expansion, the I/O points not being used as I/O can be used as internal relays.	
With I/O Expansion unit	50 (total I/O)
Internal Coils	160
Retentive coils (latches)	59
Non-retentive coils	96
Special Function coils	5
Timers/Counters (4-digit)	20*
*(Four of the Timers/Counters can only be used with the Timer/Counter Setpoint unit)	
Shift Registers	155 total steps
Sequencers (1000 step)	20
High Speed Counter	
Counting Speed	2 kHz
Range	0 to 9999
Inputs:	
Incremental (up) Pulse (circuit 15)	
Reset Pulse (circuit 16), minimum pulse width for input 16 is 0.1 mSec.	
(Circuits 15 and 16) can be used as discrete 24 V dc sink inputs if the High Speed Counter is not used.	

PROGRAMMABLE CONTROLLER CONCEPTS

When using a new product for the first time, there are always new concepts and terms to become familiar with. Although PCs are easy to install, program, and apply, there are some simple principles to follow. Figure 1.3 illustrates a general block diagram of a Programmable Controller. Specific hardware components to illustrate this diagram will be shown later in Chapter 2.

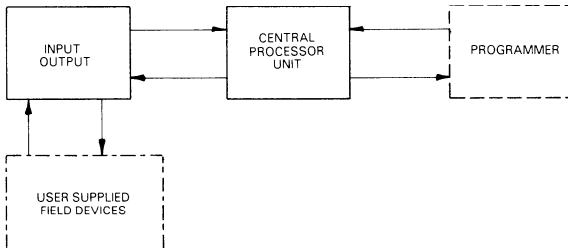

Figure 1.3 PC GENERAL BLOCK DIAGRAM

PROGRAMMING THE SERIES ONE JUNIOR PC

The hand-held programmer is used to enter the specific logic the user desires the PC to follow. This logic, to be described in detail in Chapter 3 is what makes the user's PC a unique unit that is different from all others, unless the identical logic is entered into another unit. Recording and reloading logic from one PC to another or to itself is also a standard feature with this programmer. The hand-held programmer can display any previously entered logic, allow the user to edit it (make changes, add or delete portions of the logic), or display the current value of any internal timer or counter. The hand-held programmer can be permanently connected to the PC or removed without disturbing the operation of the PC.

A Series One Junior can also be programmed with the LCD Portable Programmer, which allows you to program in ladder diagram format. The Portable Programmer uses a liquid crystal display which allows ladder logic rungs to be displayed as they are entered. The ladder program can be documented using a standard parallel or centronics compatible printer. Refer to GEK-90846 for detailed information on using the Portable Programmer.

FUNCTION OF THE CENTRAL PROCESSOR UNIT

The next element of the PC is the Central Processor Unit (CPU). The CPU is the "brain" behind all logical decision making. It reads in the status of the control system, makes decisions based upon the logic it has been provided, and then provides decisions to the actuating portion of the control system. The CPU also performs self checking of its internal operation to ensure reliable operation. If an error is detected, it will shut itself down. The logic entered by the programmer is actually stored in the CPU along with storage for the operation of timers and counters.

TYPES OF MEMORY USED FOR PROGRAM STORAGE

The memory provided for this storage function is normally measured in K words, where K is an abbreviation for kilo or 1024. Typically, one word is required storage for each function such as a relay contact, timer preset or timer storage. These words can be of various lengths such as 16 bits, 8 bits, or even 4 bits, wherein a bit is the most elementary measurement and can have only two states (on or off). The word length is much like a ruler used to measure wire, sheet steel, or fabric. It can be a yard long (16 bits) or a foot (8 bits) or an inch (4 bits); numerical values are for illustrative purposes only and do not represent exact ratios. Thus when quoting memory in K words (1K, 2K, 4K, etc.) always check to verify the length of the word. The Series One uses the most common measurement, 16 bits per word, which is also the most stringent for PCs.

There are several types of memory used in PCs to store both logic and data. The two most commonly used are CMOS and PROM. CMOS is an acronym commonly used for CMOS RAM (Complimentary Metal-Oxide Semiconductor, Random Access Memory). CMOS is a fast, low cost, low power memory that can be easily examined (read) and changed (written). However, it is volatile — it can lose its content if power is removed. To avoid reloading memory (and losing counts and system status) everytime power is turned off, the CMOS memory is usually provided with a battery to maintain its content (not system operation) when power fails. Due to the low

power drain of CMOS technology, a single new lithium battery can maintain memory without application of power for up to 2 to 5 years. The battery is not used when power is applied and the system is operating normally. Its storage or shelf life is typically 8 to 20 years.

The second type of memory is PROM (Programmable Read Only Memory) which also is fast, and has a relatively low cost. Unlike CMOS memory, its contents are retained upon loss of power. However, this memory cannot be easily changed, although it can be examined (read) at anytime. But to change (write) it requires some special action on the part of the user. In this system, the PROM must be clear of all previous contents (either new, or erased with an intense ultraviolet light) and then placed into a special loader called a PROM writer. A previous logic program developed in CMOS is then written into the PROM. Finally, the PROM is removed from the PROM writer and inserted in a socket in the CPU.

FUNCTION OF THE INPUT/OUTPUT CIRCUITRY

The final element of the PC is the Input/Output section. Electrical noise such as spikes on the power lines, inductive "kick-back" from loads, or interference picked up from field wiring is very prevalent in industrial applications. Since the CPU operates at relatively low voltage levels (typically 5 volts), this noise would have serious impact on its operation if allowed to reach the internal circuits of the CPU.

The I/O section, both inputs and outputs, protects the CPU from electrical noise entering through the I/O modules or wiring. The I/O section is where status signals are filtered to remove noise, voltage levels are validated, and where decisions made by the CPU are put into operation. Inputs provide their status to a storage area within the CPU and outputs are driven from similar stored status in the CPU.

The Series One Junior I/O is fixed, that is, a specific quantity and type of inputs and outputs are provided on each basic unit. If a Series One 5 or 10-slot rack is used to expand the quantity of I/O in a Series One Junior system, the I/O inserted in these racks is modular in design and can accommodate a variety of signals. A complete discussion of the types and capacities of Series One I/O modules available for use with a Series One Junior PC is provided in Chapter 6. The specific type of I/O module, for example, 115 Vac or 24 Vdc, is usually determined by the field device selected by the user.

SYSTEM PLANNING

Decisions such as number of 115 Vac solenoids, 24 Vdc solenoids, motor starters, limit switches (their voltages), control panel lamps (what voltage?), pushbuttons, and external relays have a major impact on the configuration of any PC. These parameters should be established as early as possible in the overall design of the control system. Of course, being a flexible device, the PC configuration either on paper or in hardware, can be changed if requirements change. Typically, the user provides the field devices, wires them to the I/O section, and provides the power source to operate them.

COMMUNICATING WITH OTHER DEVICES

The Data Communications Unit (DCU), IC610CCM100A provides the ability for the Series One Junior PC to communicate with external devices. These devices can be other programmable controllers, computers, or other smart devices. User programs and I/O information in the Series One Junior PC can be uploaded and downloaded to or from any master device that supports the Series Six CCM2 protocol as defined

in the Series Six Data Communications Manual, GEK-25364. For detailed information on how to use a DCU in a Series One Junior system, refer to the applicable manual which is GEK-90477, Data Communications for the Series One, Series One Junior, And Series Three Programmable Controllers.

PC TERMINOLOGY

To summarize the preceding discussion of Programmable Controller concepts, Table 1.3 provides a list of terms discussed above that you should be familiar with relating to PCs. A more complete list of terms is provided in the glossary at the end of this manual.

Table 1.3 PC TERMINOLOGY

TERM	DEFINITION
PC	Programmable Controller or Programmable Logic Controller. An industrial control device using microprocessor technology to perform logic decision making with relay ladder diagram based programming.
Programmer	A device for entry, examination and alteration of the PC's memory including logic and storage areas.1
Logic	A fixed set of responses (outputs) to various external conditions (inputs). All possible situations for both synchronous and non-synchronous activity must be specified by the user. Also referred to as the program.
CPU	Central Processor Unit — the physical unit in which the PC's intelligence resides. Decision making is performed here.
Memory	A physical place to store information such as programs and/or data.
K	An abbreviation for kilo or exactly 1024 in the world of computers. Usually related to 1024 words of memory.
Word	A measurement of memory length, usually 4, 8, or 16 bits long.
CMOS	A read/write memory that requires a battery to retain its content upon loss of power.
PROM	A read only memory that requires a special method of loading, but is inherently retentive upon power loss.

Table 1.3 (Continued)

I/O	Input/Output — that portion of the PC to which field devices are connected. Isolates the CPU from electrical noise.
Noise	Undesirable electrical disturbances to normal signals generally of high frequency content.
Input	A signal, typically ON or OFF, that provides information to the PC.
Output	A signal typically ON or OFF, originating from the PC with user supplied power to control external devices based upon commands from the CPU.
Field Devices	User supplied devices typically providing information to the PC (Inputs: pushbutton, limitswitches, relay contacts, etc.) or performing PC tasks (Outputs: motor starters, solenoids, indicator lights, etc.).

CHAPTER 2 PHYSICAL EQUIPMENT CONFIGURATION

INTRODUCTION

This chapter contains a general hardware description of the Series One Junior Programmable Controller. You will become familiar with the features of the basic units, expansion units, expansion racks, accessories, and the optional peripheral devices. After reading this chapter and becoming familiar with the available hardware, proceed to Chapter 3 for a detailed description of the procedures required to install a Series One Junior Programmable Controller system.

EQUIPMENT CONFIGURATION

Each Series One Junior Programmable Controller is self-contained in a single package. This package contains a power supply, 24 I/O terminals for connection to user input devices or loads to be controlled, and the CPU (Central Processing Unit). The CPU is an intelligent device that makes decisions based on the user program stored in memory and then executes instructions based on those decisions.

Configuration of a system is relatively easy using a Series One Junior PC. First, you must add a programmer for entering or changing the programs required for controlling a machine or process. The snap-on programmer can mount on the Series One Junior for operator convenience when entering programs. It can also connect to the Series One Junior through a 5 foot (1.5m) cable, or it can be mounted on the outside of a panel or console by using the optional programmer mount assembly, which is described later.

In addition to adding a programmer, connections must be made from input devices, such as limit switches and sensors, to the input terminals located at the top of the unit. I/O references for a Series One Junior PC are marked on the case adjacent to each terminal. Connections must also be made from the output terminals at the bottom of the unit to the motor, machine, or whatever is being controlled. A 115 or 230 V ac power source must be connected to the appropriate terminals located on the lower right of the Series One Junior. UL approved units can operate only from 115 V ac power source.

If more than 24 I/O points are required for your application, an expansion rack can be added by connecting an I/O expansion cable to the expansion connector mounted on the left side panel of the Series One Junior PC. The opposite end of the cable plugs into a connector mounted on the faceplate of the optional expansion module. This module must be inserted in the slot adjacent to the power supply on the expansion rack. The expansion cable is available in three lengths, 3' (1m), 30' (10m), and 100' (30m). Standard Series One 5 or 10-slot racks can be used as expansion racks. If no more than 50 I/O are required, an I/O Expansion unit can be connected to a basic unit through an I/O Expansion cable.

Any of the Series One I/O modules can be used in an expansion rack, with the exception of the Thumbwheel Interface module (IC610MDL105A), and the High Speed Counter module (IC610MDL110A). One 16 point I/O module can be used, but can only be placed in the first I/O slot immediately adjacent to the I/O Expansion module.

Table 2.1 is a list of catalog numbers for Series One Junior PC basic units, expansion racks, cables, and accessories that can be used with those units.

Table 2.1 SERIES ONE JUNIOR PROGRAMMABLE CONTROLLER CATALOG NUMBERS

DESCRIPTION	CATALOG NUMBER
Basic Units	
115 V ac IN, 115/230 V ac OUT	IC609SJR100
24 V dc Sink IN, 115/230 V ac OUT	IC609SJR102
24 V dc Sink IN, 24 V dc Sink OUT	IC609SJR110
24 V dc Sink IN, 24 V dc Sink OUT	IC609SJR114
24 V dc Sink IN, Relay OUT	IC609SJR120
24 V dc Sink IN, Relay OUT	IC609SJR124
24 V dc Source IN, Relay OUT	IC609SJR121
I/O Expansion Units	
24 V dc Sink IN, 24 V dc Sink OUT	IC609EXP110
24 V dc Sink IN, Relay OUT	IC609EXP120
24 V dc Source IN, Relay OUT	IC609EXP121
UL Listed Units	
Basic Unit	
115 V ac IN, 115 V ac OUT	IC609SJR101
Expansion Unit	
115 V ac IN, 115 V ac OUT	IC609EXP101
Programmer (Hand-Held)	
Programmer w/Key Switch	IC610PRG100/105
CPU To Programmer Cable 5' (1.5m)	IC610CBL100
Programmer Mount Assembly	IC610PRG190
Remote CPU/Programmer Cable 5' (1.5m)	IC610CBL102
Key, Programmer (10 keys)	IC610ACC100
I/O Expansion Racks And Cables	
I/O Expansion Module	IC610CCM109
Series One 5-slot Rack	IC610CHS110
Series One 5-Slot Rack w/24 V dc PS	IC610CHS114
Series One 10-Slot Rack	IC610CHS130
Series One 10-Slot Rack w/24 V dc PS	IC610CHS134
I/O Expansion Cable 3' (1m)	IC609CBL191
I/O Expansion Cable 30' (10m)	IC609CBL192
I/O Expansion Cable 100' (30m)	IC609CBL193

Table 2.1 CATALOG NUMBERS (Continued)

Expansion I/O Modules

Any Series One I/O module can be used in the Series One Junior Expansion Rack except the following:

- Thumbwheel Interface module IC610MDL105
- High Speed Counter module IC610MDL110

Accessories

- Data Communications Unit IC610CCM100
- Printer Interface Unit IC610PER151
- PROM Writer Unit IC610PER154
- Battery IC610ACC150
- PROM Memory (4 chips) IC610ACC151
- Portable Programmer IC610PRG110

FRONT AND SIDE PANEL FEATURES

Each Series One Junior Unit has several features on the front and side panel which are common to all models. These items are described in the following paragraphs. Figure 2.1 is an illustration showing the front panel features.

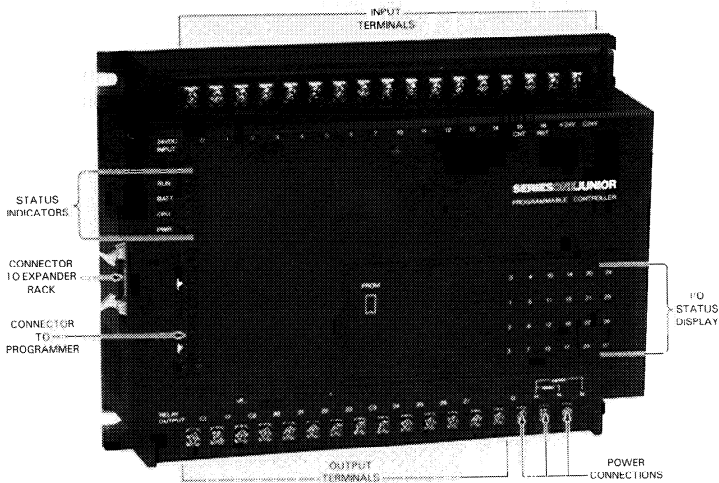

Figure 2.1 FRONT PANEL FEATURES

STATUS INDICATOR LIGHTS

Four LEDs are located on the upper left front of the unit. These LEDs; RUN, BATT, CPU, and PWR, are visual indicators of the operating status of the Series One Junior.

RUN	This green LED monitors the status of the operating state of the CPU.
ON	CPU is in the RUN mode.
OFF	CPU is in a mode other than RUN, either PROGRAM, LOAD, or TAPE.
BATT	This red LED monitors the condition of the CMOS RAM memory back-up battery.
ON	Battery voltage is low and may not properly maintain the contents of user memory under a no-power condition.
OFF	Battery voltage OK, or battery is disconnected.
CPU	This red LED monitors the status of the CPU circuitry in the Series One Junior PC unit.
ON	A CPU failure has been detected.
OFF	CPU circuitry is operating normally.
PWR	This green LED monitors the status of the dc power being produced by the internal power supply.
ON	Indicates that +5 V dc is being produced by the internal supply.
OFF	The internal +5 V dc not producing voltage, ac source of input voltage to unit is missing, or internal component failure.

FRONT PANEL CONNECTOR

The 26 pin connector located directly below the status indicator LEDs provides the connection to the programmer when user programs are to be entered, modified, or monitored. The programmer can be attached directly to the Series One Junior PC by placing the mating connector on the rear of the programmer over the 26-pin connector and gently pushing down on the programmer until the programmer snaps into place.

The programmer can also be attached using the 5' (1.5m) Series One CPU to programmer flat ribbon cable. This allows hand-held programmer operation. A third method of connecting the programmer to the Series One Junior is by using the programmer mount assembly. A dust cover protects the programmer when it is not being used.

I/O STATUS DISPLAY

On the lower right of the front panel is an LED display, numbered 0 to 7, 10 to 17, and 20 to 27. These 24 LEDs indicate the real time status, either ON or OFF, of the 15 input and 9 output I/O points. The LED numbers on the lens correspond to the input and output circuit numbers printed on the unit adjacent to each terminal. The programmer, when attached, can provide a similar display on its LEDs through the use of the monitor function. Beneath the lens can be found a socket used to contain the optional EPROM for user program storage.

FIELD WIRING TERMINALS

There are 17 terminals on the top (front view) and bottom (front view) of the unit for field wiring connections. Each of the terminal blocks is protected by a removable plastic cover. This cover snaps into place and is keyed for proper orientation on the terminal blocks. When looking at the ends of the terminal blocks, notice that one end has 2 notches, while the other end has 3 notches. The covers have 2 protrusions on one end and 3 on the other, these must be properly matched to the terminal blocks. The covers have removable paper inserts, which provide a convenient means of circuit annotation.

Top Terminals

The top terminals, labeled 0 to 16, provide a total of 15 connections to input devices. The last two input terminals (15 and 16) can be used for the high speed counter incremental pulse input and the reset pulse input. If terminals 15 and 16 are not being used as high speed counter inputs, they can be used as dc sink inputs. The function of the remaining terminals depends on the model. For most models, the last two terminals supply 24 V dc @ 100 mA, maximum, which can be used as a source of power for external user devices, such as sensors.

Bottom Terminals

The bottom terminals provide the connections to field devices to be controlled by the PC's output circuits. There are connections labeled 17 through 27, which correspond to the 9 output circuits, and their commons, labeled C1, C2, and C3. On future versions of catalog number IC609SJR100, the connections currently labeled C1, C2 and C3 will be H1, H2 and H3. This is to reflect that they are the "Hot" ac connections. The C terminal immediately to the right of terminal 27, is for connecting the shielded wire when an expansion cable is connected to a Series One Junior (see Figure 1.2). The 4 remaining terminals are for connecting the input source of ac power. These 4 terminals are labeled G (Ground), H (Hot), N (Neutral for 115 V ac), and N (Neutral for 230 V ac)

WARNING

ENSURE THAT PROPER CONNECTIONS ARE MADE WHEN CONNECTING AN AC SOURCE OF POWER. IF 230 V AC IS APPLIED TO THE 115 V AC NEUTRAL TERMINAL, THE UNIT MAY BE DAMAGED. THE 230 V AC NEUTRAL TERMINAL HAS A PROTECTIVE TAG ON IT, WHICH SHOULD NOT BE REMOVED UNLESS A 230 V AC POWER SOURCE IS TO BE USED.

SIDE PANEL CONNECTOR

A 10-pin connector located on the left side of the Series One Junior will accept an I/O expansion cable, when required, for connection to an expansion rack. A dust cover provides protection for the connector when a cable is not connected.

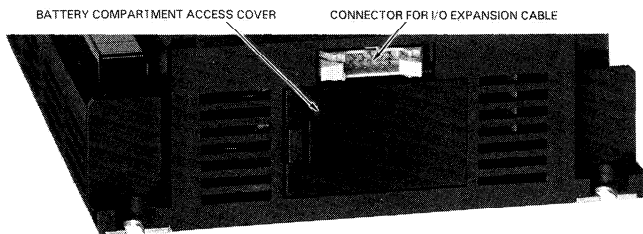

Figure 2.2 SIDE PANEL FEATURES

BATTERY COMPARTMENT ACCESS COVER

Located directly below the side panel connector is a snap-in, rectangular cover plate which allows access to the lithium battery used as a source of back-up power for the CMOS RAM user memory. When replacing the cover plate, the snap-lock should be positioned at the top of the access area.

PROM SOCKET

Directly beneath the lens on the front of the unit is a spare socket to be used for containing a PROM that has been loaded with the user program contained in CMOS memory. The PROM should be an Intel 2732A-2 or equivalent. User programs can be written (loaded) into the PROM with the optional PROM Writer unit. To access the socket, pull up the left side of the lens next to the slot in the Series One PC faceplate.

The PROM is inserted with its notch aligned with the notch in the socket as shown in Figure 2.3. For instructions on loading a PROM from RAM, refer to the instructions in Chapter 4 of this manual. Instructions for using the IC610PER154 Prom Writer unit are also printed on the front of the unit for easy reference.

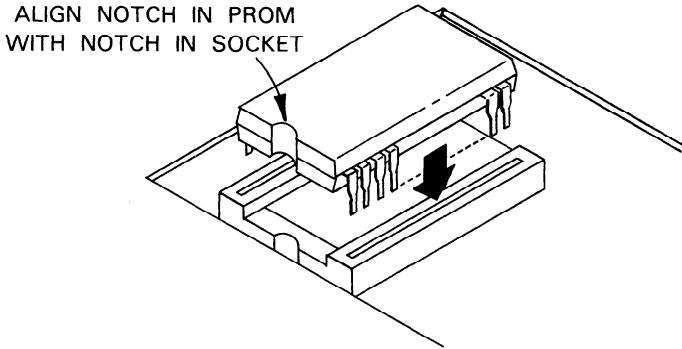

Figure 2.3 PROM ORIENTATION INTO SOCKET

If a program in RAM memory is running, AC power is turned off, a PROM is inserted containing a different program, then power is applied, the program contained in PROM will execute. If AC power is again turned off, the PROM is removed, and power applied, the original program in RAM will then execute. If a blank PROM is inserted, the program in RAM will execute, since the CPU will detect a blank PROM as no PROM. With this feature it can be seen that a number of PROMs could each be loaded with a different program for controlling various applications.

CAUTION

IT IS SUGGESTED THAT THE USER CAREFULLY DOCUMENT THE PROGRAMS AND PUT A PROGRAM IDENTIFICATION CODE ON EACH PROM SO THAT PROGRAMS ARE NOT MISMATCHED WITH THE APPLICATION. IF THIS PRECAUTIONARY MEASURE IS NOT FOLLOWED, DAMAGE TO EQUIPMENT MAY OCCUR.

PROGRAMMER TAPE PORT

The Programmer, when installed on the Series One Junior basic unit, provides an auxiliary port, labeled TAPE, as the connection to allow memory transfers to peripheral devices. Tape recordings of programs can be made on virtually any audio cassette recorder and once made can be used to initialize the CPU in any PC to that program. Thus programs can be made once and transported to other PCs without manually being re-entered. Once entered they can be edited if required. In the unlikely event that a PC fails, a replacement can be installed and quickly reloaded to specifically perform the task its predecessor was accomplishing, if a tape record was made. The TAPE port can also be used to transfer the user program to PROM memory or obtain a printout of the logic in the same format as it was entered (Boolean) using the stand-alone printer. These functions are discussed in more detail under installation, Chapter 4.

PROGRAMMER MOUNT ASSEMBLY

The programmer mount assembly can be used to mount and protect the programmer on the outside of a panel or console. A programmer, when mounted externally, can be used as an operator interface unit to change timer or counter presets, monitor timer or counter current values, monitor 16 consecutive I/O points, or monitor the entire contents of the user program. The programmer mount assembly includes a mounting bezel, a clear plastic cover, and a cable fastener. In addition to the mounting assembly, a shielded, round CPU-Programmer cable (Catalog No. IC610CBL102A), designed specifically for mounting the programmer away from the PC, must be used when installing the programmer in this manner.

The programmer mount assembly bezel installs on the outside of a panel or console with only four screws. The programmer snaps into the bezel using its two snaplocks. A clear plastic cover then fits over the bezel and programmer, thereby protecting it from its industrial environment. The programmer mount assembly can also be used as a table top stand for the programmer by mounting four rubber feet, which are included with the assembly, on the reverse side of the bezel using the panel mounting holes.

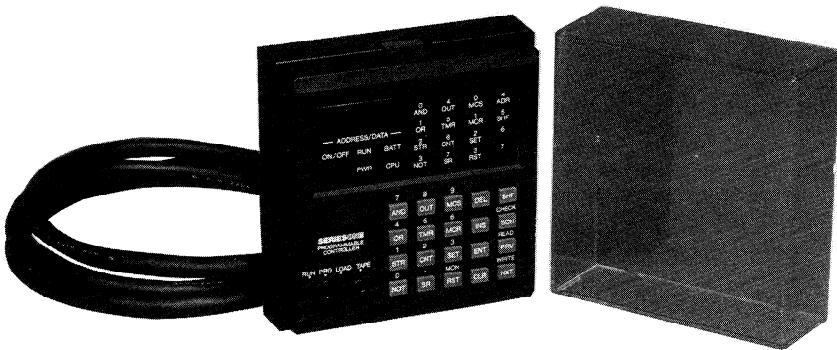

Figure 2.4 PROGRAMMER MOUNT ASSEMBLY

I/O EXPANSION REQUIREMENTS

If more than 24 I/O points are required in a Series One Junior PC system, an expansion rack or I/O Expansion unit must be installed. With an expansion rack connected to a Series One Junior basic unit, up to 72 additional I/O points can be added to the system, thereby allowing a total of 96 I/O points. An I/O Expansion unit provides 26 I/O points, allowing up to 50 I/O points in a system.

The I/O expansion system allows the expansion rack to be located at a distance of up to 100' (30m) from the basic unit. This provides a convenient method of allowing the I/O modules in the expansion rack to be close to the machine or process being controlled. The required hardware for an I/O expansion system with an expansion rack is as follows.

- | | | |
|----|---|-------------|
| 1. | I/O Expansion Module | IC610CCM109 |
| 2. | One of the following racks: | |
| | Series One 5-slot rack | IC610CHS110 |
| | Series One 5-slot rack w/24 V dc PS | IC610CHS114 |
| | Series One 10-slot rack | IC610CHS130 |
| | Series One 10-slot rack w/24 V dc PS | IC610CHS134 |
| 3. | One I/O expansion cable, which can be any of the following lengths: | |
| | 3' (1m) | IC609CBL191 |
| | 30' (10m) | IC609CBL192 |
| | 100' (30m) | IC609CBL193 |
| 4. | Any combination of Series One I/O modules with the exception of: | |
| | Thumbwheel Interface module | IC610MDL105 |
| | High Speed Counter module | IC610MDL110 |

The I/O slot adjacent to the power supply in the expansion rack must contain the I/O Expansion module. The next 4 slots can contain either 4 or 8 point I/O modules, up to a total of 40 I/O points. In addition, one 16-point module (and only one) can be inserted in I/O slot 1 of a rack. Each of the I/O slots is assigned 8 I/O points by the CPU. For example, if an 8 point I/O module is placed in slot 1, the I/O references are 030 to 037. If a 4 point I/O module is placed in slot 1, the I/O references for that module are 030 to 033. The remaining I/O references for slot 1 (034 to 037), in the case of the 4 point module, are then available for use as internal coils. When used as internal coils, they can provide status to other logic, but are not available to control "real world" hardware outputs.

I/O EXPANSION RACK REFERENCES

If a 16-point I/O module is placed in slot 1, the I/O references for that module are 030-037 and 130-137. I/O references for 5 and 10-slot expansion racks are as shown below.

SLOT NUMBER	I/O REFERENCE
1	030 to 037 and 130 to 137
2	040 to 047
3	050 to 057
4	060 to 067
5	070 to 077
6	100 to 107
7	110 to 117
8	120 to 127
9	130 to 137 (if all 8 point modules)

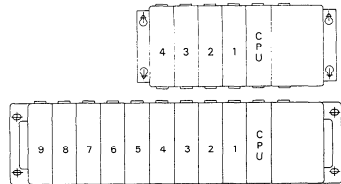
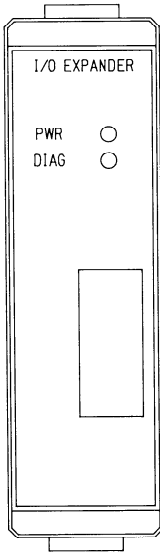

Figure 2.5 I/O REFERENCE PER SLOT LOCATION

A 16-point I/O module can only be placed in slot 1 of a 5 or 10-slot rack. Only one high-density 16-point module can be used in a system. The I/O references for that module are 030 to 037 and 130 to 137 as shown in Figure 2.5.

I/O EXPANSION MODULE FACEPLATE

The I/O Expansion module faceplate, refer to Figure 2.6, has 3 hardware features, which include 2 status indicator lights and a 10-pin connector. The 10-pin connector provides the connecting link from the expansion module to the Series One Junior PC through an I/O expansion cable, which was described previously. The function of the 2 indicators is described below.



- PWR** This LED indicator monitors the condition of the +5 V dc power supplied by the power supply in the expansion rack.

 - ON** +5 V dc is being properly produced by the rack power supply.
 - OFF** Rack power supply is not producing +5 V dc, the required source of input power to the supply is missing, or blown fuse.
- DIAG** Provides an indication of the operating status of the I/O Expansion module.

 - OFF** I/O Expansion module operating normally.
 - ON** A hardware error has occurred internally in the I/O expansion module and its watchdog timer has timed out.

Figure 2.6 I/O EXPANSION MODULE

NOTE

For configuration information on I/O Expansion units, refer to the end of this chapter.

EXPANSION RACKS

The Series One racks are available to be used as an expansion option if a Series One Junior installation is to have more than 24 I/O. Each rack contains a power supply to the right and space for up to either 5 or 10 modules. Racks are available in 2 versions, one powered by 115/230 V ac, the other powered by 24 V dc. Each supplies internal power to the modules inserted into the rack. Mounting is provided by attached brackets at the rear of the rack, each with two keyholes. All racks are similar; differences being the function of the rack as determined by the placement of modules by the user, the number of modules which may be inserted into a rack, and the input power required.

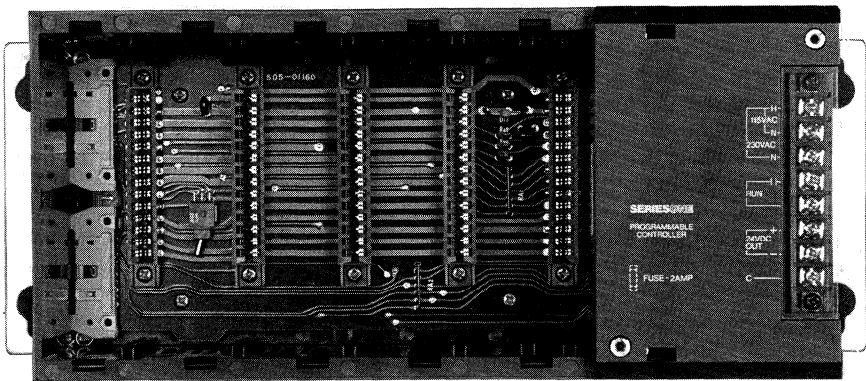

5-SLOT RACK

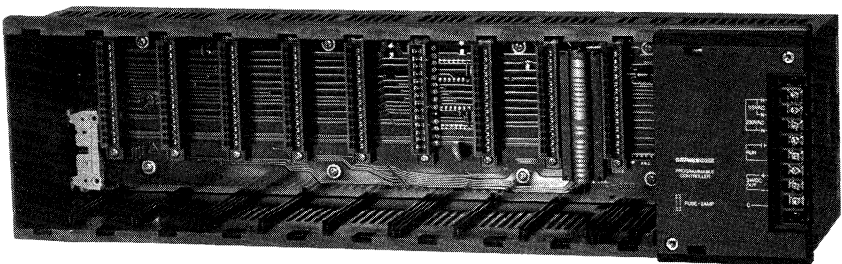

10-SLOT RACK

Figure 2.7 TYPICAL SERIES ONE RACKS

RACK MOUNT BRACKETS

Rack mount brackets are available to adapt the 10-slot racks for mounting in 19 inch racks. With the brackets assembled on either version of a 10-slot rack, the rack can be mounted on standard mounting rails in 19 inch cabinets and consoles.

I/O MODULE PLACEMENT IN RACKS

The available I/O slots can contain I/O modules in any mix of inputs versus outputs or voltage levels required by the user's application. All modules are secured to the rack by two snap-locks which can be released by squeezing the module top and bottom toward the center (see Chapter 3 for additional details).

EXPANSION RACK HEAT DISSIPATION

Each Series One rack is designed to dissipate internal heat through convection cooling only and does not require a fan for forced air cooling. However, to ensure efficient operation, free air flow should not be inhibited at the top and bottom of the unit. If a rack is panel mounted, a minimum space of 3 inches (75mm) is recommended at the top and 4 inches (100mm) at the bottom. Both sides should be free of obstacles to allow easy removal of the unit. Approximately 3 inches (75 mm) from each side excluding the mounting brackets is recommended. Furthermore, the unit should be oriented horizontally and not inverted nor rotated 90°. Placements of other sources of large volumes of heat near the units should also be avoided, especially directly below the rack. For reliable operation, the air entering the bottom of the rack should not be at a higher temperature than 60°C (140F°).

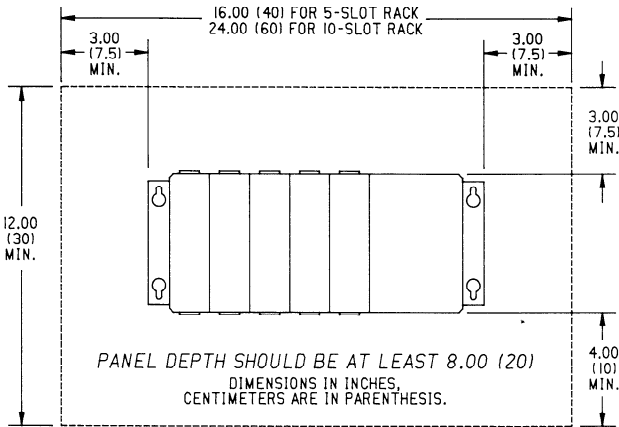

Figure 2.8 EXPANSION RACK MOUNTING CONSIDERATIONS

ROUTING OF FIELD WIRING

Field wiring to the Series One Junior, I/O modules in the expansion rack and power supplies should be placed so as to avoid blocking the air flow, yet provide a suitable service loop to allow easy removal of modules with wiring attached. Wires should be tied to maintain their order in the event they must be disconnected for any reason.

DATA COMMUNICATIONS UNIT

The Data Communications Unit (DCU) provides the ability for external devices to communicate with the Series One Junior PC. These devices function as a host to the Series One Junior PC and can be other programmable controllers, computers, or other smart devices. User programs and I/O information in the Series One junior PC can be uploaded and downloaded to or from any master device that supports the Series Six CCM2 (Communications Control Module, Version 2) master/slave protocol as defined in GEK-25364, which is the Series Six Data Communications Manual. The Series One Junior can only function as a slave device during a communications session. Refer to GEK-90477, Series One/Three Data Communications manual, for instructions on using the DCU.



Figure 2.9 DATA COMMUNICATIONS UNIT

PERIPHERAL DEVICES SUPPORTING SERIES ONE JUNIOR

Several peripheral units are available to support a Series One Junior Programmable Controller. A basic description of these units is provided in the following paragraphs. For a more detailed description of the use and operation of these units, refer to Chapter 4, Operation, in this manual.

PRINTER INTERFACE UNIT

The Printer Interface Unit is a compact, easy-to-use plug-on device that attaches to the Series One Junior PC in the same manner as the programmer. This peripheral interfaces to many readily available personal computer printers and provides a means of obtaining a hard-copy printout of the user program in either boolean or ladder diagram format. An illustration of the Printer Interface Unit is shown in Figure 2.10.



Figure 2.10 PRINTER INTERFACE UNIT

PROM WRITER UNIT

Also available is a PROM Writer unit, which allows the user program in CMOS memory to be transferred to PROM memory, thereby providing a convenient method of non-volatile (permanent) storage for those programs. The PROM Writer unit is a compact, easy-to-use plug-on unit which attaches directly to the PC in the same manner as the programmer. In addition to providing a means of non-volatile storage, an added advantage of PROM memory is that several PROMs can be programmed, each containing a different program, for use as required. Figure 2.11 is an illustration of the PROM Writer Unit.



Figure 2.11 PROM WRITER UNIT

I/O EXPANSION UNITS

I/O Expansion units can be included as a part of a Series One Junior system when more than 24 I/O points are required. The physical form, size and appearance are identical to the basic unit. Any one of the expansion units can be used with any of the basic units to provide up to 50 I/O points in your Series One Junior PC system. There is no requirement to match voltage types, you can mix or match as required by your application.

An I/O Expansion unit connects to a basic unit through an I/O Expansion cable, available in 3 lengths, which are 3' (1m), 30' (10m), and 100' (30m). The I/O Expansion cable is the same cable that is used when connecting a basic unit to a 5 or 10-slot expansion rack.

I/O EXPANSION UNIT SPECIFICATIONS

The type and I/O capacity of each of the I/O Expansion units, and total I/O available when used with a basic unit is as shown in Table 2.2. General specifications for each unit are listed in Table 2.3.

Table 2.2 I/O EXPANSION UNIT TYPE AND NUMBER OF I/O

Catalog Number	Description of Unit	Expansion Unit		Basic Unit Plus Expander Unit Available I/O Quantity
		Inputs	Outputs	
IC609EXP110	DC SINK IN/DC SINK OUT	16	10	50
IC609EXP120	DC SINK IN/RELAY OUT	16	10	50
IC609EXP121	DC SOURCE IN/RELAY OUT	16	10	50*

*Two of the inputs in the basic unit are DC sink.

Table 2.3 GENERAL SPECIFICATIONS

Required AC Power	115/230 V ac, ± 15%
Frequency	47 to 63 Hz
Power Consumption	
IC609EXP110	25 volt-amps
IC609EXP120	30 volt-amps
IC609EXP121	30 volt-amps
Operating Temperature	0° to 60°C (32° to 140°F)
Storage Temperature	- 10° to 70°C (14° to 158°F)
Humidity (non-condensing)	5% to 95%
Noise Immunity	Conforms to NEMA ICS3-304
Vibration	Conforms to JIS C 0911 IIB Class 3
Shock	Conforms to JIS C 0912

Table 2.3 GENERAL SPECIFICATIONS (Continued)

Dimensions (All same as basic unit)	Width—8.25" (210mm) Height—6.4" (162mm) Depth—2.2" (56mm)
Expansion Cable Lengths IC609CBL191 IC609CBL192 IC609CBL193	3 feet (1m) 30 feet (10m) 100 feet (30m)

I/O EXPANSION UNIT FEATURES

Each of the Series One Junior I/O Expansion units has features located on the front and side panels which are common to all versions. These items are described below and illustrated in the following figure.

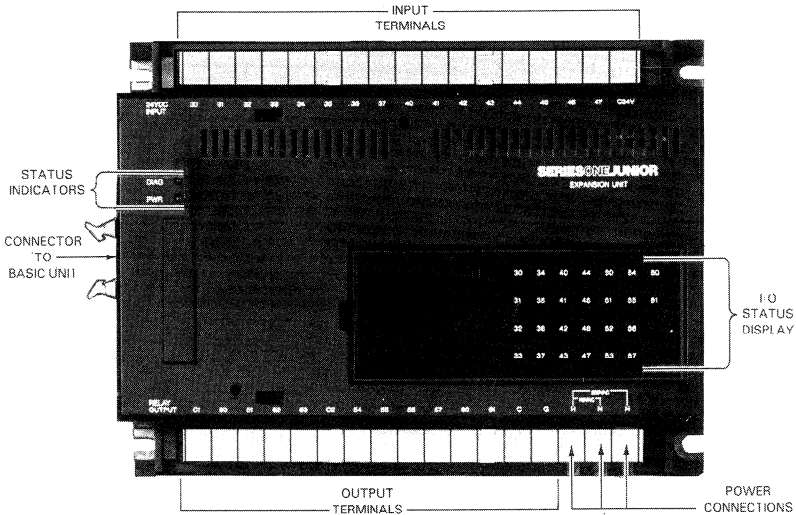

Figure 2.12 I/O EXPANSION UNIT FEATURES

STATUS INDICATOR LIGHTS

There are two LEDs in the upper left of the front panel. These LEDs, **DIAG** and **PWR**, are visual indicators of certain operating status of the I/O Expansion unit.

DIAG	This LED monitors the operation of the I/O Expansion unit.
<i>ON</i>	The I/O Expansion unit is operating normally, all I/O signals are being transferred correctly between the CPU and the I/O Expansion unit. Internal watchdog timer has not timed out.
<i>OFF</i>	A hardware error has occurred internally in the I/O Expansion unit and its watchdog timer has timed out.
PWR	Monitors the +5 V dc power supply in the I/O Expansion unit.
<i>ON</i>	+5 V dc is being properly produced by the I/O Expansion unit's power supply.
<i>OFF</i>	+5 V dc not at the proper level, the input power source to the I/O Expansion unit is missing or incorrect, or a fuse is blown in the input power line.

I/O STATUS DISPLAY

On the lower right is a group of numbers, printed on the lens, which correspond to the reference numbers for input and output terminals at the top and bottom of the unit. The reference numbers are in octal, as are all reference numbers in the Series One Junior. Each number has a corresponding LED beneath it, mounted on the printed circuit board inside of the unit. These indicators provide a visual status of the ON or OFF state of each input or output circuit.

FIELD WIRING TERMINALS

There are 17 screw terminals located at the top and bottom of the unit for field wiring connections. Each designated input or output terminal is directly connected to the corresponding input or output circuit in the I/O Expansion unit.

Each group of terminals is protected by a removable plastic cover. This cover snaps into place and is keyed for proper orientation on the terminal blocks. When looking at the ends of the terminal blocks, notice that one end has 2 notches, while the other end has 3 notches. The covers have 2 protrusions on one end and 3 on the opposite end. These protrusions must be properly matched to the notches on the terminal blocks. The covers have a removable paper insert for circuit annotation.

Top Terminals

The top screw terminals provide the connections from the input devices. The screw terminals are labeled 30 through 47 for each unit (IC609EXP110, EXP120 and EXP121) with the remaining terminal being the 0 volt connection to the internal 24 V dc supply.

Bottom Terminals — DC IN/OUT Expansion Units

IC609EXP110, 120, 121 — The bottom terminals on these units are labeled 50 through 61, corresponding to the 10 output circuits, and their commons are labeled C1 and C2. The terminal labeled C, connects to the green wire on the I/O Expansion cable. The 4 terminals to the right are for connection to the 115 or 230 V ac power source. These 4 terminals are labeled (from the leftmost one) G (Ground), H (Hot), N (Neutral for 115 V ac) and N (Neutral for 230 V ac).

SIDE PANEL CONNECTORS

A 10-pin connector located on the left side of the unit provides the means of connecting an expansion unit to a Series One Junior basic unit through an I/O Expansion cable, either 3' (1m), 30' (10m) or 100' (30m) in length. These are the same cables that can be used to connect a basic unit to a 5 or 10-slot expansion rack. Any of the expansion units can be connected to any basic unit for expansion of the I/O system. There is no requirement that the DC I/O Expansion units be connected to a DC basic unit. They can be connected to either AC or DC I/O basic units.

NOTE

The snap-in, rectangular cover plate on the side panel beneath the 10-pin connector has no useful function in an expansion unit. In the Series One Junior basic unit, this cover provides access to the CMOS RAM back-up battery. The cover is there since the form factor of both units is the same.

CHAPTER 3 INSTALLATION

INTRODUCTION

Unpack each unit carefully to ensure that there has been no shipping damage. Verify that all components of your system are received and as ordered. Each Series One Junior PC basic unit includes with it, a user's manual and an accessory kit consisting of a spare terminal cover plate, spare connector dust covers, and several spare screws for the terminal blocks. Mounting, expansion rack, and wiring instructions are provided in the following section.

INSTALLATION SPECIFICATIONS

Installation specifications for Series One Junior basic units are provided in Table 3.1 as a guide for system requirements. Table 3.2 provides a list of the installation specifications for an expansion unit, if required. The expansion unit can be a Sespecifications for an expansion unit, if required. The expansion unit can be a Series One 5 or 10-slot rack. A total of 40 I/O can be placed in the expansion rack.

Table 3.1 SERIES ONE JUNIOR GENERAL SPECIFICATIONS

Operating Temperature	0° to 60° C (32° to 140° F)
Storage Temperature	- 10° to 70° C (14° to 158° F)
Humidity (non-condensing)	5 to 95%
Required ac Power	115/230 V ac +10%/ -15%
Frequency	47 to 63 Hz
Maximum Load	25 volt-amps
Available dc power for user devices	24 V dc +10%/ -20% @ 100 mA maximum
Weight	4.1 lb (1850 grams)
Typical Battery Life	2 to 5 years
Shelf Life	8 to 10 years
Dimensions for a Basic Unit	Width 8.25" (210mm) Height 6.4" (162mm) Depth 2.2" (56mm)

Table 3.2 EXPANSION RACK INSTALLATION SPECIFICATIONS

Rack Size (W x H x D)	
5-Slot	11.4 x 4.7 x 5.5" (290 x 120 x 140mm)
10-Slot	18.3 x 4.7 x 5.5" (465 x 120 x 140mm)
Completed Rack Weight (less wiring)	4.5 lbs (2.0 Kg), 5-Slot 5.0 lbs (2.5 Kg), 10-slot
Ambient Temperature	0° to 60°C (32 to 140°F)
Storage Temperature	- 10 to 70°C (14 to 158°F)
Humidity (Non-Condensing)	5-95%
AC Power Required:	
IC610CHS100 Rack	
IC610CHS110/130 Rack	
Voltage	115V/230V ± 15%
Frequency	47-63 Hz
Maximum Load	70 volt-amps (CHS110,130)
DC Power Required:	
IC610CHS114/134 Rack	
Voltage	20.5 - 30 V dc (100% of capacity used) 18 - 30 V dc (90% of capacity used)
Ripple	± 10% of Input Voltage
Maximum Total Current	2.2 A
Vibration	Meets JIS C 0911 IIB 3
Shock	Meets JIS C 0912
Noise Immunity	Meets NEMA ICS3-304
Run relay	250V, 4 amp, Resistive Load

MOUNTING DIMENSIONS

Figure 3.1 shows dimensions for mounting all models of Series One Junior.

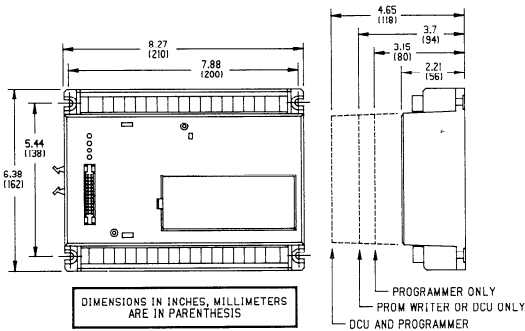

Figure 3.1 MOUNTING DIMENSIONS, BASIC UNIT

INSTALLATION INSTRUCTIONS

The Series One Junior PC can be rack or panel mounted either horizontally, vertically, or on a flat surface, as long as the upper right (as viewed on Figure 3.1) of the unit is facing up. A transformer is located internally in that area and must be facing up, when mounted, for proper heat dissipation. In addition, to ensure proper ventilation of the unit, there should be no other unit or obstruction within 1.5" (38mm) of the top and bottom, 1.5" of the right side or 2.5" (64mm) of the left (Battery access cover) side.

MOUNTING THE BASIC UNIT

1. Using a Series One Junior or by transferring the dimensions shown below to the mounting surface, mark where the 4 mounting holes are to be drilled.
2. Drill the 4 mounting holes to the required size, either for pass through bolts or for tapping. The hole should accept a 3/16" screw.
3. Tap holes if required. Insert top and bottom bolt on one side. Place the unit on the two bolts and loosely secure. Insert the two bolts on the opposite side and tighten all four bolts.

CAUTION

WHEN DRILLING OR TAPPING HOLES, ENSURE THAT METAL BITS DO NOT ENTER ANY UNIT OR EXPANSION RACK ALREADY INSTALLED. THE WORK AREA SHOULD BE CLEARED BEFORE INSTALLING UNITS OR EXPANSION RACKS.

MOUNTING AN EXPANSION RACK

4. If a Series One expansion rack is required in order to add I/O capability to the system, either a 5 or 10-slot rack can be used to contain the I/O modules. Figure 3.2 provides an outline of both 5 and 10-slot racks, including required mounting dimensions.

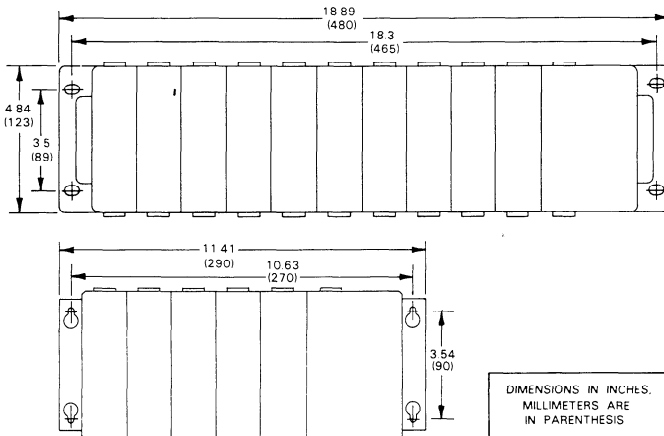

Figure 3.2 MOUNTING DIMENSIONS FOR 5 AND 10 SLOT RACKS

5. Using the 5 or 10-slot expansion rack as a template, mark where mounting holes are to be drilled.
6. Drill the four mounting holes $\frac{1}{4}$ " (6mm) if using pass through bolts, or $\frac{3}{16}$ " (5mm) if using tapped holes.
7. Insert top 2 bolts ($\frac{3}{16}$ " X $1\frac{1}{2}$ " or 5mm X 40mm), put unit in place, and loosely secure with washers, lock-washers and nuts.

OR

- 7a. Tap holes and insert top two bolts. Place unit onto mounting bolts and loosely secure.

CAUTION

WHEN DRILLING OR TAPPING HOLES ENSURE THAT METAL CHIPS DO NOT ENTER UNIT ALREADY INSTALLED. CLEAR WORK AREA BEFORE INSTALLING BASE UNITS.

NOTE

When inserting the 2 top bolts, attach the green jumper as shown in Figure 3.3. This jumper wire is packed with each rack and provides a method of grounding the rack when an earth ground is also connected to a mounting bracket.

8. The power supply ground connection is located on the mounting bracket instead of the "G" terminal on the power supply. A jumper wire is included with each rack to interconnect the mounting brackets.

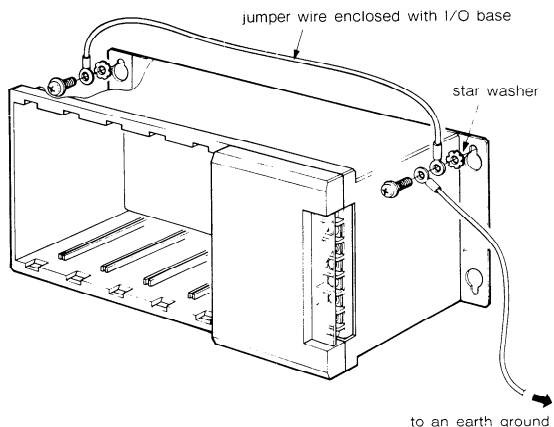

Figure 3.3 RECOMMENDED EXPANSION RACK GROUNDING

9. Complete the installation of the bottom two bolts and tighten all mounting hardware. Power supplies are shipped installed in an expansion rack.

10. Select the proper length I/O expansion cable, either 3', 10', or 100', and insert one end of the cable in the connector on the left side of the Series One Junior PC. Both connectors are keyed for proper insertion. Connect the shield to the C terminal on the right side of the bottom terminal block on the Series One Junior (refer to Figure 3.4).
11. Connect the opposite end of the cable to the top connector on the I/O expansion module. The I/O expansion module must be installed in slot 1 in the expansion rack. Connect the shield to the C terminal on the power supply terminal block located on the right side of the expansion rack (see Figure 3.5).

POWER CONNECTIONS

Series One Junior Basic and I/O Expansion Units

12. Connect a source of required ac power, either 115/230 V ac or 24 V dc, to the proper terminals on the lower terminal block on the Series One Junior. Three wires are required for ac units, hot, neutral, and ground. For dc units a + and - dc connection is required.

WARNING

ENSURE THAT PROPER CONNECTIONS ARE MADE WHEN CONNECTING AN AC SOURCE OF POWER. IF 230 V AC IS APPLIED TO THE 115 V AC NEUTRAL TERMINAL, THE UNIT MAY BE DAMAGED. THE 230 V AC NEUTRAL TERMINAL HAS A PROTECTIVE TAG ON IT, WHICH SHOULD NOT BE REMOVED UNLESS A 230 V AC POWER SOURCE IS TO BE USED.

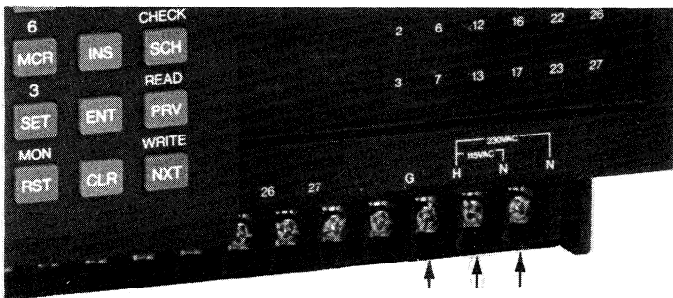

Figure 3.4 POWER CONNECTIONS

Expansion Rack

13. Either 115/230 V ac or 24 V dc power connections are made to the terminal block on the far right of each unit. See table 3.2 for power requirements. The minimum recommended wire size for power connections is AWG No. 18 (1mm).

14. Strip 0.4 ± 0.1 inches (10 ± 2 mm) of insulation from each wire (hot, neutral, and ground) or place a No. 6 insulated lug (ringed or forked) onto each wire.
15. Remove the plastic cover from over the terminal strip. Connect the hot wire to the top terminal. The neutral is connected to either the next (second) terminal for 115V operation or the third terminal for 230V operation as marked on the rack.

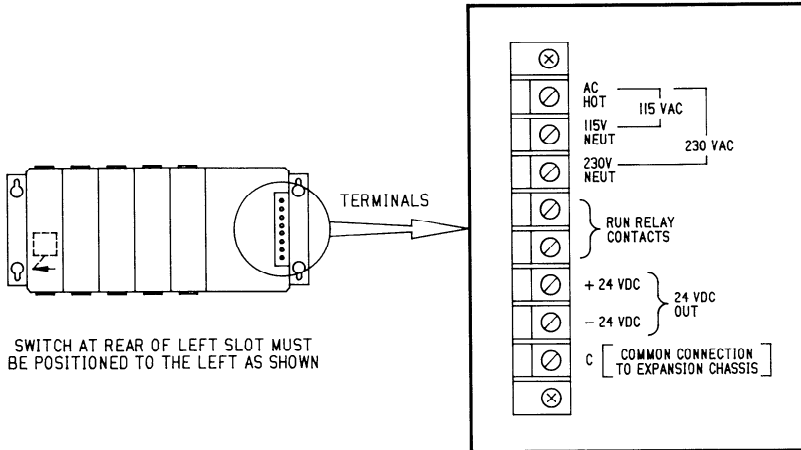

Figure 3.5 EXPANSION RACK TERMINAL STRIP LOCATION

WARNING

DO NOT USE THE TOP SCREW FOR POWER CONNECTIONS; IT SECURES THE TERMINAL BLOCK. VERIFY CONNECTIONS BEFORE APPLYING POWER.

16. The next two terminals are connected to the RUN relay. Use of this standard feature on the expansion rack is optional. It can be used to drive an external indication of the functional state of this rack. The Run relay is closed when the Series One Junior CPU is scanning.
17. If the Run indication is desired, it can be wired separately to an external indicator (light, bell, whistle, etc) or in series with other racks. When all wiring is complete replace the plastic cover.
18. Connect an earth ground wire to the rack mounting bracket as shown in Figure 3.3. (Typically this ground wire is the green wire from the ac power source.)

WARNING

ENSURE THAT ALL EXPOSED WIRING IS EITHER UNDER THE SCREW-DOWN PLATE OF THE TERMINALS OR INSULATED BY SHRINK TUBING OR SLEEVES.

INSERTING I/O MODULES INTO AN EXPANSION RACK

19. Tilt the module approximately 10° as shown in Figure 3.6. Insert the bottom of the large printed circuit board into the bottom card slot in the rack.
20. When the bottom slot is engaged, rotate the module slightly to engage the top slot. Slide the module into the rack until it is firmly seated and the snap locks fully engage.

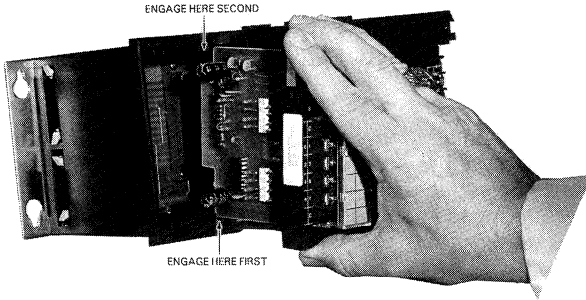

Figure 3.6 MODULE INSERTION INTO EXPANSION RACK

21. To remove a module from an expansion rack, squeeze the top and bottom snap locks (Figure 3.7) towards the center and pull the module straight out. Squeeze force should be about 10 pounds (5 Kg) and pull force about 8-12 pounds (4-6 Kg).

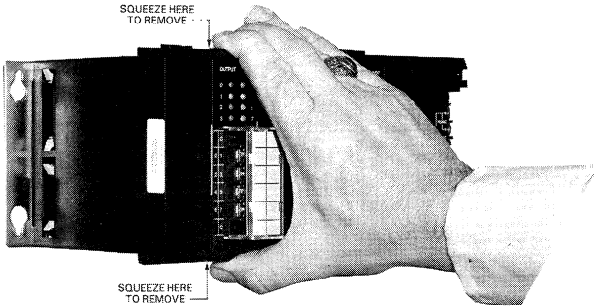

Figure 3.7 MODULE REMOVAL FROM EXPANSION RACK

I/O FIELD WIRING

22. Recommended wire size for connection of field wiring to the I/O terminals on the Series One Junior basic unit and I/O Expansion unit or to the terminals on the I/O modules installed in the expansion rack is stranded AWG No. 12 (2mm) wire. Two wires per terminal are possible with AWG No. 14 (6mm) wire.

23. Strip 0.3 ± 0.05 inches (8 ± 1.5 mm) from each wire to be connected to the basic or expansion unit or to the terminals on the I/O modules or install a No. 6 insulated lug (ringed or forked) on each wire. Bare wire connections are recommended for multiple wire connections to one terminal.
24. Connect all field wires from input devices to the proper input terminals at the top of the basic or expansion unit. Connect all field wiring to loads to the proper output terminals at the bottom of the basic or expansion unit.
25. Carefully remove plastic covers over the I/O terminals on the connections (modules in expansion rack) by lifting top or bottom leg and sliding it to right or left.
26. For wiring to modules in the expansion rack, starting with the lower four terminals (0, 2, 4, and 6), connect the field wires to all I/O terminals. Power connections such as those to commons (C) should be made last. No connections are required to unused circuits; however, screws on unused terminals should be tightened.

WARNING

ENSURE THAT WIRES TO THE TOP SET OF TERMINALS DO NOT EXTEND BEYOND THE SCREW-DOWN PLATE. ANY WIRE EXPOSED BEFORE THE TERMINAL PLATE MUST BE COVERED BY SHRINK TUBING OR SLEEVES.

27. If a 16-point module requiring a cable with D-connector is installed in the expansion rack, secure the connector on the I/O Interface cable to the connector on the module.
28. Wires should be laced together to leave a service loop adequate for removal of I/O modules without disconnecting wires. Wires to and from I/O modules should be run in conduit or otherwise neatly maintained in place. After testing of I/O wiring, replace the plastic covers.

PROGRAMMER (HAND-HELD)

29. The hand-held programmer (catalog no. IC610PRG100) can be attached to the Series One Junior PC by placing the mating connector on the rear of the programmer over the 26-pin connector located on the left side of the front panel and gently pushing down on the programmer until the programmer snaps into place.
30. If the programmer is to be used with the 5' (1.5m) extender cable (catalog no. IC610CBL100), it can be installed next, or when required. One end of the cable has a pull tab (see Figure 3.8). This end is connected to the programmer. The other end is connected to the 26-pin connector on the Series One Junior basic unit. Both ends are keyed for proper installation. The red edge of the ribbon cable is installed up at both ends.

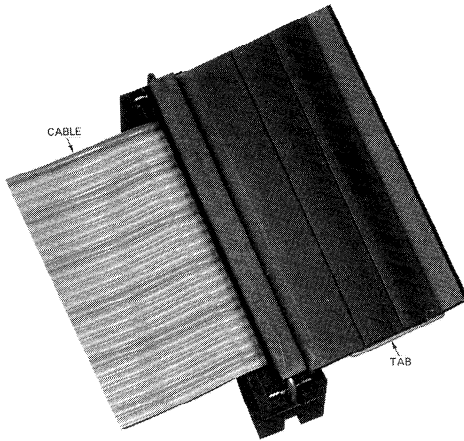

Figure 3.8 PULL TAB ON PROGRAMMER CABLE

NOTE

For proper noise immunity, the extender cable should be used on a temporary basis and not permanently installed with the programmer.

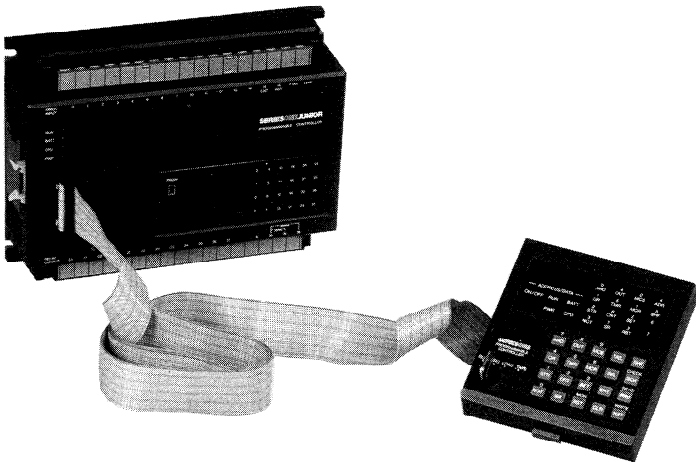

Figure 3.9 INSTALLATION OF PROGRAMMER CABLE

PROGRAMMER MOUNT ASSEMBLY

31. The Programmer Mount Assembly (catalog no. IC610PRG190) can be used when installing the programmer on the outside of a panel or console, or can be used as a table top stand for the programmer. Figure 3.10 shows how to install this assembly.

• HOW TO MOUNT THE CONNECTOR

CPU/PROGRAMMER CABLE
(IC610CBL102A) ROUND CABLE
OR
(IC610CBL100A) FLAT CABLE

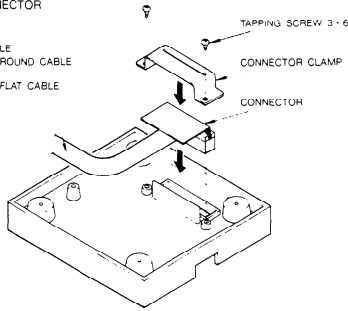

• WHEN USED AS A BENCH-TYPE

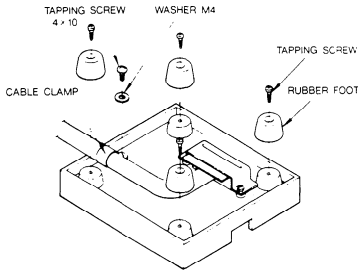

• WHEN MOUNTED ON A PANEL

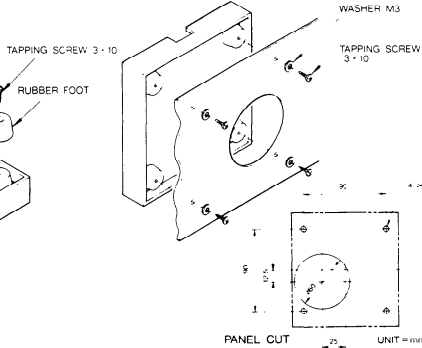

Figure 3.10 PROGRAMMER MOUNT ASSEMBLY

CAUTION

TO ENSURE PROPER CPU OPERATION, IT IS RECOMMENDED THAT THE PROGRAMMER NOT BE CONNECTED NOR DISCONNECTED WITH AC POWER APPLIED.

POWER SUPPLY LIMITATIONS FOR EXPANSION RACKS

If the power supply in an expansion rack should become overloaded, unpredictable system operation may occur. To ensure that this does not happen, the total current capabilities of the I/O modules placed in the rack must not exceed the current carrying capabilities of the rack power supply.

The power used by each I/O module is expressed in units of load, where 1 unit equals 10 mA. Calculations are based on the worst case condition with all inputs and outputs on. Table 3.3 lists the units of load supplied by each rack, and Table 3.4 is a list of units of load used by each I/O module. When configuring a rack, note the units of load supplied, then add the total units of load used by the modules you have selected. The total units of load for the modules must not exceed the total units of load supplied by the rack. If they do, the system should be redesigned.

Table 3.3 UNITS OF LOAD SUPPLIED BY RACK

CATALOG NUMBER	RACK DESCRIPTION	POWER SUPPLIED IN UNITS OF LOAD			
		+ 5 V	+ 9 V	+ 24 V	+ 24 V EXTERNAL
IC610CHS110	5-slot rack	140	80	40	10
IC610CHS114	5-slot w/24 V P/S	140	80	40	—
IC610CHS130	10-slot	140	160	40	10
IC610CHS134	10-slot w/24 V P/S	140	160	40	—

Table 3.4 UNITS OF LOAD USED BY I/O MODULES

CATALOG NUMBER	MODULE DESCRIPTION	POWER USED IN UNITS OF LOAD		
		+ 5 V	+ 9 V	+ 24 V
IC610MDL101	24 V dc Sink Input (8)	—	1	10
IC610MDL102	24 V dc Srce Input (16)	—	2	19
IC610MDL103	24 V dc In/Out (4/4)	—	2	7
IC610MDL104	24 V dc In/Relay Out (4/4)	—	20	6
IC610MDL106	24 V dc Sink In w/LEDs (16)	—	3	24
IC610MDL111	24 V dc ac/dc Input (8)	—	1	—
IC610MDL115	Fast Response I/O (4/2)	—	8	6
IC610MDL124	I/O Simulator (8) Inputs	—	1	11
IC610MDL125	115 V ac Input (8)	—	1	1
IC610MDL126	115 V ac Isol Input (4)	—	1	—
IC610MDL127	230 V ac Input (8)	—	1	—
IC610MDL151	24 V dc Sink Output (8)	—	2	3
IC610MDL152	24 V dc Sink Output (16)	—	5	4
IC610MDL153	24 V dc 2A Sink Out (4)	—	1	1
IC610MDL154	24 V dc Sink/Srce Out (4)	—	1	10
IC610MDL155	24 V dc Srce Output (8)	—	3	—
IC610MDL156	24 V dc Snk Out w/LEDs (16)	—	4	10
IC610MDL175	115/230 V ac Output (8)	—	16	—
IC610MDL176	115/230 V ac Isol/OUT (4)	—	8	—
IC610MDL180	Relay Output (8)	—	34	—
IC610CCM100	Data Communications Unit	30	—	—
IC610PER151	Printer Interface	26	—	—
IC610PER154	PROM Writer	50	—	—

1 unit of load = 10 mA. Calculations are based on the worst case, that is, all inputs and outputs on.

Table 3.4a UNITS OF LOAD FOR UL LISTED PRODUCTS

UNITS OF LOAD SUPPLIED BY RACK					
CATALOG NUMBER	RACK DESCRIPTION	POWER SUPPLIED IN UNITS OF LOAD			
		+ 5 V	+ 9 V	+ 24 V	+ 24 V External
IC610CHS111	5-Slot 115 V ac	140	80	50	10

UNITS OF LOAD USED BY I/O MODULES

CATALOG NUMBER	MODULE DESCRIPTION	POWER USED IN UNITS OF LOAD		
		+ 5 V	+ 9 V	+ 24 V
IC610MDL135	115 V ac Input	—	1	—
IC610MDL181	Relay Output	—	23	—
IC610MDL185	115 V ac Output	—	12	—

INSTALLATION OF EXPANSION UNITS

When installing an I/O Expansion unit, the expansion unit connects to a Series One Junior basic unit through an I/O Expansion cable, as mentioned above. All of the installation procedures for installing I/O Expansion units are the same as for installing the Series One Junior basic units.

The expansion units can be rack or panel mounted either vertically, horizontally or on a flat surface. When mounted vertically, the transformer should be at the top of the unit. A transformer located under the cover must be facing up when mounted, to ensure proper heat dissipation. There should be no other unit or obstruction within 1.5" (38mm) of the top, bottom and right side, and 2.5" (64mm) of the left side.

The illustration below shows a typical installation with an I/O Expansion unit connected to a Series One Junior basic unit.

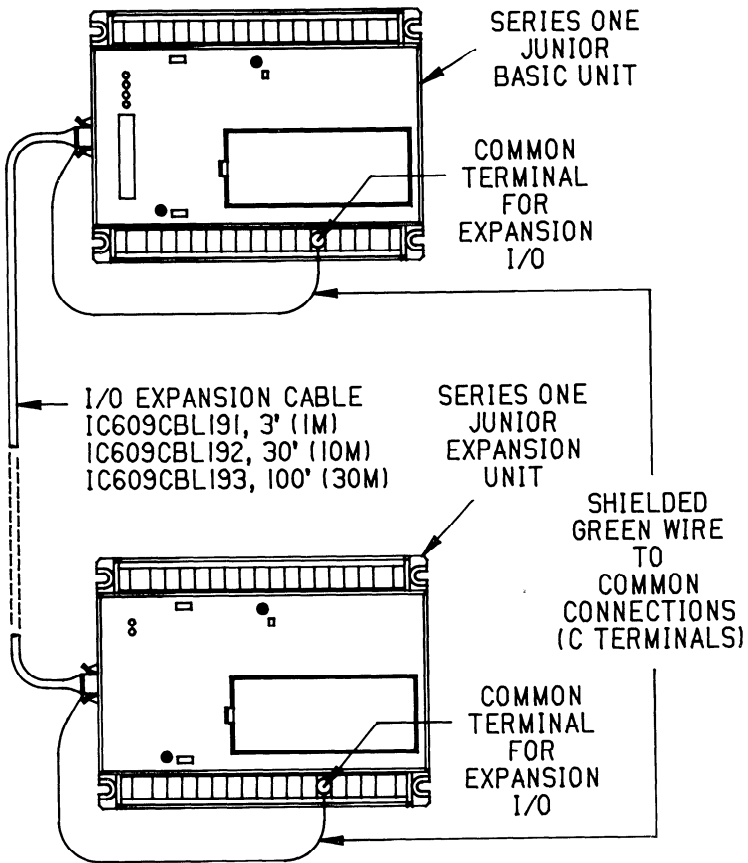

Figure 3.11 TYPICAL I/O EXPANSION UNIT INSTALLATION

REMOTE MOUNTING OF TIMER/COUNTER UNIT

A Unit mounting Bracket, IC610ACC190, is available to allow mounting of the Timer/Counter Unit on the outside of a panel or console. The Timer/Counter Setpoint Unit mounts on the bracket, as shown below, secured by two captive screws on the Timer/Counter Unit. The Timer/Counter Unit connects to a Series One Junior PC through the round 5 foot (1.5m) Remote Programmer Cable, IC610CBL102.

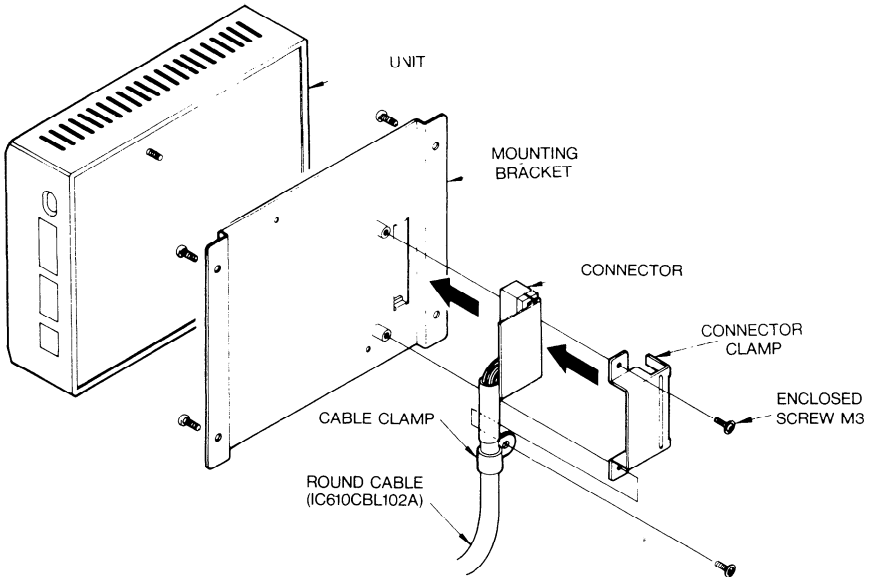

Figure 3.12 INSTALLATION OF UNIT MOUNTING BRACKET

CHAPTER 4 OPERATION

INTRODUCTION

After completing the installation procedures described in the previous chapter, your Series One Junior PC is ready for operation. This chapter describes the operation of a Series One Junior PC. A description of the features and functions of the programmer are the basis for the information in this chapter. In addition, the last portion of this chapter describes the operation of peripheral devices that can be used with a Series One Junior PC. The information in this chapter will allow you to become familiar with the programmer keys and the keystroke sequences required for the various programmer operations.

PROGRAMMER

The hand-held programmer, when attached to the Series One Junior by one of the three methods described in the previous chapter, can be used for entering a new program, examining a previously entered program, editing (changing) a previously entered program if required, monitoring the status of input or output points, and displaying timer or counter accumulated values. Figure 4.1 is an illustration of the programmer. Its features and functions are described in the following paragraphs. For detailed descriptions of the programming functions, refer to programming, Chapter 5.

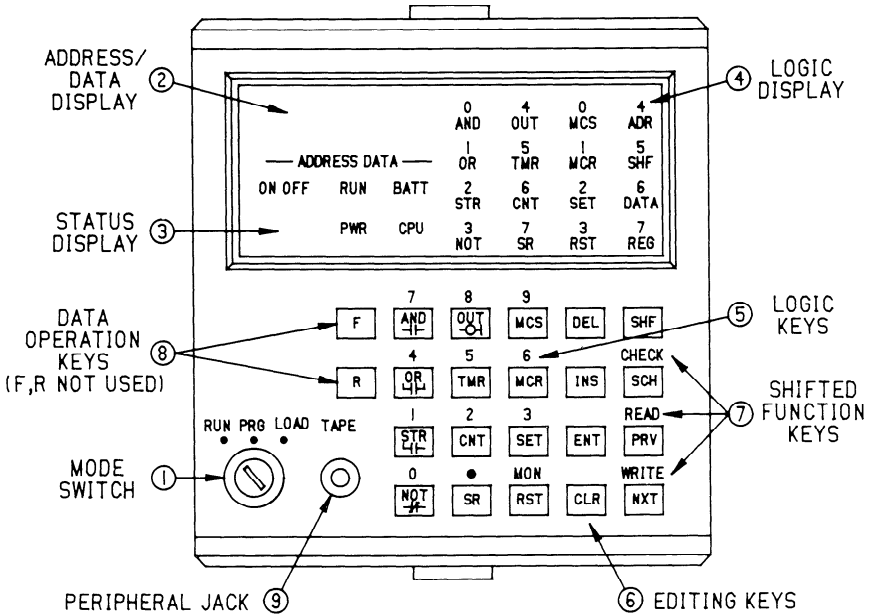

Figure 4.1 PROGRAMMER FEATURES

PROGRAMMER FEATURES

The features of the hand-held programmer shown in the illustration on the previous page are described in this section. The descriptions of the features are keyed to the numbers (1 to 8) next to each feature in the illustration.

1. MODE SWITCH

This is a three-position keyswitch used for selecting the operating mode of the PC. This switch can be repositioned at any time as necessary without disrupting AC power. The left position (RUN) allows program execution with outputs enabled. The CPU scans its stored logic and allows timer/counter and relay contacts to be displayed. However, in the Run mode, changes to the logic are not allowed. In the center (PRG or Program) position, new programs can be entered and previously entered logic can be altered; however, no solving of the logic is performed. The right (Load) position connects the programmer to an external device such as a tape recorder through the adjacent tape port. Logic is not solved while in the Load position.

WARNING

IF A VERSION A OR B (IC610CPU101A OR IC610CPU101B) CPU IS INSTALLED, THE SERIES ONE JUNIOR PROGRAMMABLE CONTROLLER WILL ALWAYS POWER UP IN THE RUN (OPERATING) MODE UNLESS A PROGRAMMER IS CONNECTED AND THE PROGRAMMER IS IN THE PROGRAM OR LOAD MODE.

2. ADDRESS/DATA DISPLAY

This is a four digit display used to indicate either the address, in decimal format, of where the display is in the user program stored in the PC's memory or reference data used as a part of the logic. To indicate that addresses are being displayed, periods appear near the bottom and to the right of each digit (for example, 0.1.2.3.). The LED to the top right behind ADR will also be lit.

3. STATUS DISPLAY

These five LEDs are energized to indicate the following functions or status of the Series One:

ON/OFF	When in the Run mode, this LED indicates the status of discrete references (I/O, internal coils, and shift register stages). It is ON when a reference is energized and OFF when de-energized.
RUN	ON when in the RUN mode and CPU is solving logic.
BATT	ON when the voltage of the internal lithium battery, which is used for maintaining the program stored in CMOS memory during no-power conditions, is at a low level and should be replaced within 10 days — see Chapter 7. This LED is OFF when battery voltage is OK, or battery is disconnected.

PWR	ON when the internal power supply is producing DC power. If OFF the Series One Junior's power supply should be checked — see Chapter 7.
CPU	ON when internal error checking has detected a fault in internal hardware — see Chapter 7.

The above four LEDs (RUN, BATT, PWR and CPU) duplicate the operation of the indicators on the CPU when the programmer is installed. The four CPU indicators on the Series One Junior are located in the lower left section of the front panel, directly above the 26-pin connector.

4. LOGIC DISPLAY

These sixteen LEDs are used to indicate the type of logic entered into memory. While being programmed, they reflect the logic selected by the user prior to actual entry into CPU memory. For definition of the first 12 LED's functions, see key definitions under 5 below. The two LED's to the upper right have special functions as follows:

ADR	ON when display is indicating an address value. The address is displayed in decimal notation, beginning at 0000 and ending at the last address in the user program or a maximum of 0700 (maximum number of 16-bit words in memory).
SHF	On when operator has selected the Shift key and is an indication that future key selections will be based upon the upper key labels. Shift function will remain in effect until either the Enter or Clear key is selected.

These sixteen LEDs can also indicate the status of 16 consecutive I/O states when used with the monitor function discussed later in this chapter. The numerals above the alphabetical characters are used during this function.

5. LOGIC KEYS

These twelve keys are used to select the required function and enter logic when in the Program mode. The upper labels are used to enter numerical values when preceded by the Shift key. Numerical values, when entered, are viewed in the Address Data display. The decimal point is used only for the entry of timer preset values in tenths of a second. The Monitor function will be discussed below as part of the Upper Case keys. The function of the lower or normal case labels on these keys is described in the following key discussion.

AND	Places logic such as two contacts or two groups of contacts in series (see Figure 4.2). Power flow must be possible through both elements before it will be passed to the next element.
OR	Places logic such as two contacts or two groups of contacts in parallel (see Figure 4.3). Power flow can be possible through either (or both) elements before it will be passed to the next element.

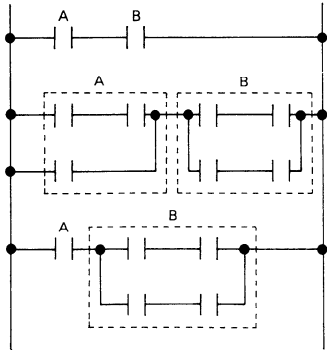

EXAMPLES OF AND (A • B)

Figure 4.2
SERIES LOGIC (AND)

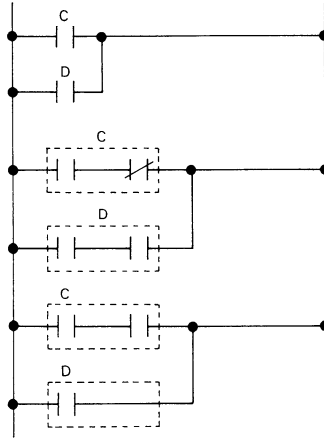

EXAMPLES OF OR (C + D)

Figure 4.3
PARALLEL LOGIC (OR)

- STR Begins (Starts) a new group of logic and stores current logic results into a Last In, First Out (LIFO) pushdown stack.
- NOT Inverts the state of the referenced status to create a normally closed contact. NOT AND results in a normally closed series contact. NOT OR results in a normally closed parallel contact.
- OUT Specifies the end of a string of logic by entering a coil. With a valid reference, such as OUT 19, this coil will reflect the output of the rung of relay logic by turning ON or OFF as dictated by the power flow. Outputs can be paralleled by entering additional OUT functions at the end of a rung of logic.
- TMR Specifies a timer function to end a rung of logic. The timer requires a unique 6XX reference for storage. Two types can be programmed (seconds and tenths of seconds) depending upon the numerical preset (with or without decimal point) entered after the 6XX reference. For example, 0.9 or 9.0 seconds can be programmed, depending on the decimal point.
- CNT Specifies a counter function to end two logic rungs. The two logic rungs required by this function are count and reset. Count, being the top rung of conditional logic. When all programmed conditions permit power flow, the counter will begin counting. The bottom rung is the reset rung and is programmed with the conditional logic required for resetting the counter. The counter also requires a unique 6XX reference for storage. Transition detection is a standard built-in function.

SR	Specifies a Shift Register function to end three logic rungs (input, clock, and reset). The reference used with SR (for example, SR 150) is the first stage of this shift register. The last stage must be entered immediately after the SR and its reference. A shift register can contain a total of 155 steps or several shift registers can be programmed, each with a different number of steps, as long as the total of 155 steps is not exceeded.
MCS	The MCS (Master Control Start) key specifies the beginning of a Master Control relay function. This provides an efficient method of programming for controlling large quantities of coils if a specific permissive condition is not satisfied.
MCR	The MCR (Master Control Reset) key specifies the end of a Master Control relay function. A similar number of MCRs must be entered to terminate, one at a time, the Master Control Start functions entered. One MCR terminates only one previous MCS function.
SET	Used with latches, shift registers, and coils. It specifies where latches are to be turned ON (set), shift register stages set to the ON state, or coils to be turned ON and not affected by internal reference 376 (disable all outputs).
RST	Performs functions similar to the SET key for latches, shift registers, and coils, except it specifies when these references will be turned OFF (reset).

6. EDITING KEYS

These eight keys select the action required to modify either the stored logic within the CPU or the logic address being displayed. Those keys that can modify previously entered logic (that is, Delete and Insert) require a confirming key operation to ensure that the operation is to be executed.. Thus, if they are accidentally depressed, the error can be corrected by depressing the CLR (Clear) key without actually affecting any entered logic. A description of each editing key is as follows:

DEL	When logic is being displayed, this key (Delete) when included as the first keystroke of a two key sequence, will cause that single function to be removed (deleted) from the CPU memory. To be effective, after depressing Delete, the PRV (Previous) key must be depressed, which executes the delete operation.
INS	This key (Insert) allows logic functions to be inserted between existing logic functions. The function or its address that is after the location at which the new function is to be placed, is displayed. Then the new logic is built followed by the Insert key (not the Enter key) and the confirming NXT (Next) key. The new logic that is inserted by this key sequence will be placed in memory immediately before the displayed function or address.

-
- ENT** The ENT (Enter) key is used to complete the entry of logic when initially building the CPU program or to replace an entire single word function. Logic functions are entered typically at the end of the existing logic.
- CLR** The CLR (Clear) key, when selected, clears the programmer of previously entered commands. If error codes are displayed, this key will acknowledge the error and return the programmer to its normal (cleared) function. When monitoring a program, depressing Clear will cause the display to indicate the memory address in lieu of logic functions. When the key sequence CLR, SHF, 3, 4, 8, DEL, NXT is entered, the entire contents of memory will be cleared.

NOTE

This key sequence should be used with caution, be sure that you want to clear the entire program. Remember, if single functions or groups of functions are to be cleared, the DEL key, followed by PRV should be selected for each function to be cleared.

- SHF** This key (Shift) locks all other keys to their shifted (upper label) functions and causes the SHF LED to be lit in the display area. The shift operation is ended by selecting the keys Clear or Enter. The SHF key must precede a numerical key or a group of numerals before selecting the numerical keys. For example to enter an open contact with input reference 12 as the first contact in a rung of logic, the key sequence would be STR, SHF, 1, 2, ENT.
- SCH** This key (Search) allows the entire program to be searched for specific logic functions. The logic function is defined by the logic keys (without Enter), then Search is selected. The memory will be searched from the current location until either a match is found or all memory is searched. Successive depressions of this key will cause repeated searches with memory wrap-around. An unsuccessful search results in error code E99 being displayed.
- PRV** When displaying logic or monitoring I/O state, selecting the PRV (Previous) key causes the previous logic function or I/O status to be displayed. Additional depressions of this key cause the display to decrement until memory address zero is reached.
- NXT** When displaying logic or monitoring I/O state, selecting the NXT (Next) key causes the next logic function or I/O status to be displayed. Additional depressions of this key cause the display to increment until end of memory is reached.

7. SHIFTED FUNCTIONS

The Shift key, when selected, causes most keys to change their function to those marked on the face of the programmer directly above the corresponding keys. Normal unshifted functions are as placed on the keys themselves. Most of the shifted functions are used when entering numerical values (digits 0-9 plus the decimal point). When entering a program, the unshifted functions must be selected first (AND, OR, NOT, OUT, TMR, etc.), then the SHF is selected to enter the numerical portion of the program. The use of the other four shifted functions are as follows:

MON When in the Run mode, this function allows the user to monitor the status of I/O references in two successive groups of 8. The specified I/O reference is used to select the first 8 references and the next group in numerical sequence is also shown to provide a total of 16 real time statuses. The specified reference should be the first reference in a group of 8, for example, specify 10 to monitor the I/O group 10 to 17. If a reference other than the first one in a group is specified, monitoring of the I/O will default to the first reference in the group. After the reference (for example 043) is entered and displayed (for example 040) as data, the status of the 8 references in that group (for example 040-047) are displayed by the first 8 LED's (AND, OR, STR, etc) in the logic display.

The next 8 references (e.g. 050) are also displayed and their status is indicated by the last 8 LED's (MCS, MCR, SET, etc). These 16 LED's will be ON or OFF as the I/O assigned to these references is energized or de-energized. As the I/O changes, the state of the LEDs changes.

To display another group of I/O references, the PRV or NXT key can be selected to decrement (40, 30, 20, etc.) or increment (50, 60, 70, etc) the group number and its associated references. References up to 577 can be displayed; there is automatic wrap-around from 570 to 000 (NXT) or 000 to 570 (PRV). The current values of timers and counters can also be monitored by entering TMR or CNT, 6XX (timer or counter reference) followed by MON (the Monitor Key).

WRITE This function operates with an audio tape cassette recorder or certain other peripherals to effect a transfer of the CPU's logic to the peripheral. Connect the device to the tape port with the audio cable supplied with each programmer or peripheral. Set the mode switch to LOAD and turn the device ON. To begin the transfer, select the WRITE key. This starts the writing of the CPU logic onto the cassette or other peripheral. For more detailed information on transferring data to peripheral devices, refer to the discussion of each peripheral.

READ	This function operates with the audio tape cassette recorder or other peripheral to load a CPU's memory from the cassette or other storage device. Connect the device to the tape port with the audio cable supplied with each programmer or peripheral. Set the mode switch to LOAD and select the READ key. To begin the CPU loading, turn the device ON. This starts the reading of the tape and the loading of the stored program into the CPU memory.
CHECK	This function operates with the audio tape recorder or other peripheral to verify proper program transfer. After a transfer is made, it should be read back similar to the READ above; however, the CHECK key must be selected instead of READ. The Check operation does not alter either the CPU logic nor the data in the peripheral. A data compare is made between the two sources of information to ensure that there has been no error in the recording process.

NOTE

The F and R keys and the DATA and REG notation in the Logic Display are not used with a Series One Junior.

PROGRAM CHECKING AND ERROR CODES

When entering ladder logic programs with the programmer, the CPU automatically performs many checks on the data and operations selected by the programmer. Functions entered are checked for proper key sequence, proper range of references entered, etc. Errors detected during these checks are indicated in the data display by the letter E followed by a two digit code (01-99). The CPU also performs the program error check any time that the PC is switched to the RUN mode.

Table 4.1 summarizes the meaning of each error code, its cause, and possible methods of clearing the error. The use of the programmer to enter logic is documented in Chapter 5 as part of programming. However, there are many other valuable functions it provides which are shown in the following Table:

Table 4.1 ERROR CODE DEFINITIONS

Code	Applicable Mode			Significance	Cause	Corrective Action
	Run	Prog	Load			
E1	X	X	X	Incorrect Operation	Operator attempted to perform illegal operation such as changing program in RUN mode.	Examine operation. Depress CLR. Reinitiate proper function.
E2	X			Fault in Program structure.	CPU Has detected error in program when placed into RUN Mode. Example: Input module reference used as coil.	Go to Program mode. Depress CLR. Address of faulty logic will be shown. Depress NXT to display content.
E3	X			Stack Capacity Exceeded.	More than eight status levels attempted to be stored in push-down stack.	Go to Program mode. Depress CLR. Programmer will display location of first 9th STR error. Examine logic and reprogram as necessary.
E5	X			Duplicate Coil Reference.	Coil (output, internal, timer, or counter) used as an OUT more than once.	Go to Program mode. Depress CLR. Programmer will display location of second coil of pair using same reference. Enter another coil reference.
E6	X			Incomplete Master Control	More MCR references than MCS in program.	Go to Program mode. Depress CLR. Programmer will display first unmatched MCR. Correct program by deleting MCR or adding MCS.
E7	X			Incomplete Counter or Shift Register.	All control lines not provided to one or more Counters and/or Shift Registers.	Go to Program mode. Depress CLR. Programmer will display errant function. Add required reset, clock or clear lines.
E8		X		Missing Numerical Value	No preset entered for timer or counters, or shift register stage reference.	Depress CLR. Programmer will display errant time, counter, or shift register. Add required value.
E9	X			Incomplete Logic	Relay ladder line not connected to coil; relay contact(s) left incomplete or hanging.	Go to Program Mode. Depress CLR. Programmer will display first unfinished logic element. Add logic to tie this element into stored logic, or delete element(s) to remove incomplete logic.

Table 4.1 ERROR CODE DEFINITIONS (CONTINUED)

Code	Applicable Mode			Significance	Cause	Corrective Action
	Run	Prog	Load			
E11		X		Memory Full	Operator attempting to add logic to CPU already at limit.	Depress CLR. Restructure program so that logic limits will not be exceeded.
E13		X		Maximum number of High Speed Counter preset points exceeded.	Operator attempted to enter more than 20 High Speed Counter preset points.	In Program mode depress CLR. Examine logic and reprogram as necessary.
E21	X	X		Parity Failure.	CPU has detected a fault in the parity structure of its internal memory.	Go to Load Mode. Depress CLR. Reload memory from previously recorded tape or clear entire memory and reload manually. If BATT light not ON and fault can not be cleared, replace CPU module.
E25			X	Faulty Comparison	External device such as tape cassette has content that does not agree with CPU memory.	Depress CLR. Verify correct program number or tape. If correct, either rerecord tape or reload CPU.
E28			X	Weak Record Signal	Playback Signal level, such as from tape recorder, is below acceptable level.	Adjust volume level on tape recorder or other peripheral device. If ON steady for extended period of time, restart function to obtain reliable operation.
E30		X		Communications lost between PC and expansion rack. CPU stops, outputs turn off.	Cable connection broken between PC and expansion rack or power loss in expansion rack.	Check cable, I/O expansion module and expansion rack power. Fix problem. Cycle system power off and on or attach programmer and switch From RUN to PRG to RUN.
E31	X			Framing error between PC and expansion rack. CPU stops, outputs turn off.	Communications lost or interrupted between PC and expansion rack.	Check cable, I/O expansion module and expansion rack power. Fix problem. Cycle system power off and on or attach programmer and switch From RUN to PRG to RUN.

Table 4.1 ERROR CODE DEFINITIONS (CONTINUED)

Code	Applicable Mode			Significance	Cause	Corrective Action
	Run	Prog	Load			
E32	X			Parity error between PC and expansion rack. CPU stops, outputs turn off.	Communications interrupted between PC and expansion rack.	Check cable, I/O expansion module and expansion rack power. Fix problem. Cycle system power off and on or attach programmer and switch From RUN to PRG to RUN.
E33	X			Expander rack does not respond to CPU's I/O configuration request during power-up sequence.	Expansion rack does not have power.	Cycle basic unit power off and on. Ensure that power is applied to expansion rack.
E99	X	X		Unsuccessful Search	Search function has reviewed all memory and has not located required function.	Depress CLR. To cause an additional search, re-enter function and restart.

OPERATION SEQUENCES

An understanding of the basic PC operation sequences is necessary in order to effectively and efficiently enter ladder diagram programs. You should be familiar with the use of each key, alone and in sequence with other keys. The programmer is an excellent tool for program entering, editing and monitoring. Table 4.2 lists the various operations, the keystrokes required to enter those operations, and the mode or modes in which the operation can be performed. Each of the modes is indicated by a letter; R (RUN), P (PROGRAM), or L (LOAD).

Table 4.2 PC OPERATION SEQUENCES

OPERATION	KEYSTROKES	MODE		
		R	P	L
Clear all memory	CLR SHF 3 4 8 DEL NXT		X	
Display present address	CLR	X	X	
Display present function	NXT	X	X	
Next function	NXT	X	X	
Previous function	PRV	X	X	
Go to first function in program memory	SHF NXT	X	X	
Go to specific address	SHF (address) NXT	X	X	
Search for a specific function	(Function) SHF (Ref. No.) SCH NXT	X	X	
Search for a specific reference number	SHF (Ref. No.) SCH NXT	X	X	
Insert function before the displayed function (or address)	(Function) SHF (Ref. No.) INS NXT			X
Monitor a group of 8 consecutive references (I/O, internal coils, Shift Register coils)	SHF (Beginning Ref. No.) MON		X	
Monitor Timer or Counter accumulated value	SHF (T/C No.) MON		X	
Force a reference ON (will be overridden by user logic)	SET SHF (Ref. No.) ENT		X	
Force a reference OFF (will be overridden by user logic)	RST SHF (Ref. No.) ENT		X	

Table 4.2 (Continued)

OPERATION	KEYSTROKES	MODE		
		R	P	L
Enter a function into program memory	(Function) SHF (Ref. No.) ENT			X
Transfer data to tape, printer, or PROM writer	(Optional program ID) WRITE			X
Load program memory from tape	(Optional program ID) READ			X
Verify data on tape or in PROM writer RAM against program memory	(Optional program ID) CHECK			X

The above table provides a convenient reference to the programmer keystrokes required for the various PC operations. A more detailed description of each operation is provided in the following discussion.

Monitor CPU Logic — This sequence of operation provides the steps required in order to observe the contents of user memory. You can either step forward or backward in user memory. With the Programmer installed and the mode switch in the Run or PRG (Program) position, observe or perform the following actions:

1. The programmer will display address zero indicated by four zero digits in the display with decimal points to the right of each digit (0.0.0.0.), and the ADR LED lit.
2. Depress the NXT key, the logic content of memory location zero will be shown (beginning of memory or scan).
3. Successive depressions of the NXT key will cause the programmer to step through the stored program in the order that the program is scanned, from address 0.0.0.0. to the last address in the program. At any time, the CLR key can be depressed to display the address of the logic then being viewed.
4. An additional depression of the NXT key will restore the display to the logic content.
5. At any time, depressing PRV will cause the logic of the previous (closer to zero) memory location to be displayed.
6. Successive depressions of PRV will cause the programmer to step backwards through the stored program in reverse of the order that the program is scanned. At location 0.0.0.0., PRV has no effect.
7. If by successive depressions of NXT, the end of the actual program is passed, the display will show End. With each successive selection (with the NXT or PRV keys) of an unprogrammed or empty memory word, the address of the new location will flash in the display for 1/4 to 1/3 of a second prior to going to End.

SEARCH CPU LOGIC — In the event that you wish to quickly find a particular logic element (programming step) in user memory, this sequence of operation allows you to do so. After installing the programmer, with the mode switch in the RUN or PRG position, observe or perform the following actions:

1. The programmer will display address zero indicated by four zero digits in the display, decimal points to the right of each digit (0.0.0.0.), and the ADR LED lit.
2. Enter the logic function whose location is to be searched for. For example, select AND, SHF, 1, 0, 5 (AND 105). Do not select ENT key.
3. Select the SCH key to begin the search. If the logic function is not found, error code E99 will be displayed.
4. If a match is found, the display will indicate the first memory address containing the desired function. Depressing NXT will cause the logic at that address to be displayed.
5. Successive depression of SCH, while the memory address is being displayed, will cause additional searches to occur from the current location.
6. As long as one match is found, the search will not stop at the end of memory, but will continue with memory address zero until a match (possibly the same location) is again detected.
7. To find the first empty memory word, depress CLR to obtain an address location. Then select SCH (search for zero content) to begin the search for the first available location.

ALTER ONE LOGIC ELEMENT — This sequence of operation allows you to change the contents of a particular location in user memory. After installing the programmer, place the mode switch in the PRG position. Observe or perform the following actions:

1. The programmer will display address zero indicated by four zero digits in the display, with decimal points to the right of each digit (0.0.0.0.), and the ADR LED lit.
2. Move the display to the element to be altered using the NXT or PRV key or Search function.
3. Enter the new logic element, for example: OR, SHF, 2, and 5 (OR 25).
4. Select the Enter (ENT) key to cause the change to occur. The new logic element you have entered will take the place of the previous logic at that memory location. The next address will be automatically displayed.
5. If the new element is not to be entered or an error has been made in its construction, depressing the Clear (CLR) key will cancel the new logic and return the display to the address of the examined element.

DELETE ONE LOGIC ELEMENT — This sequence of operation allows you to remove one logic element from the program in user memory. After installing the programmer, place the mode switch in the PRG position. Observe or perform the following actions:

1. The programmer will display address zero indicated by four zero digits in the display, with decimal points to the right of each digit (0.0.0.0.), and the ADR LED lit.
2. Move the display to the element to be deleted using the NXT or PRV key or the Search function.
3. Select the DEL key. Notice that the Address/Data display has a small “d” in the left digit of the display.
4. To confirm that the Delete operation is to be executed, select the PRV key. The next address will be displayed after the Delete is performed. The remaining user logic will automatically move back one address location (nearer to 0.0.0.0.) to fill the empty memory.
5. To cancel the Delete operation, select the CLR key (before selecting DEL). The display will revert to the element being considered for deletion.

CLEAR ALL MEMORY — This programming sequence should only be used when the entire contents of logic memory are to be cleared. After installing the programmer, place the mode switch in the PRG position. Observe or perform the following actions:

1. The programmer will display address zero indicated by four zero digits in the display, with decimal points to the right of each digit (0.0.0.0.), and the ADR LED lit.
2. Select the key sequence CLR, SHF, 3, 4, 8.
3. Select the DEL key; the display will change to $\square _ |$ —
4. To execute the clear function and cause all logic elements to be removed from user memory, depress the NXT key.
5. To cancel the clear function, the CLR key can be depressed before depressing NXT.

INSERT ONE LOGIC ELEMENT — This sequence of operation allows you to insert one logic element between two existing program steps in the user program. After installing the programmer, place the mode switch in the Program position. Observe or perform the following actions:

1. The programmer will display address zero indicated by four zero digits in the display, with decimal points to the right of each digit (0.0.0.0.), and the ADR LED lit.

2. Move the display to the element that will be after the location at which the new element is to be entered. This can be done by using the NXT or PRV key or the Search function.
3. Enter the new logic element, for example; AND, SHF, 1, 0, and 4 (AND 104).
4. Select the Insert (INS) key to cause the change to occur. Notice that the address display has a small "i" in the left digit of the display.
5. A confirming keystroke is required to ensure that the insert action by the operator is valid. To confirm the insert, select the NXT key. After the insert is performed, the display will show the address of the next logic element.

MONITOR I/O STATUS — This operation sequence allows you to monitor the status (ON or OFF) of references. A total of 16 I/O references can be monitored at any one time, beginning with the lowest address in the group with the reference selected by the operator. Each reference is within a group of 8 references. The I/O status of the group containing the selected reference, plus the next higher group of 8, is displayed. After installing the programmer, place the mode switch in the RUN position. Observe or perform the following actions:

1. The programmer will display the address zero indicated by four zero digits in the display, with decimal points to the right of each digit (0.0.0.0.), and the ADR LED lit.
2. Enter any reference to be monitored. For example, to monitor the real time status of references 020-027, or any one reference within that group, the following keys can be selected: SHF, 2 and 0.
3. Select the Monitor function (MON). Note that the shift is still in effect (selected in previous step) causing the RST key to select the monitor function.
4. The display will revert to $\overline{1}$ followed by the lowest reference (e.g. 020) in that group. If the I/O references to be monitored are assigned to a module located in a 5 or 10-slot expansion rack, the references can be for a 4, 8, or 16 point module. If the module is a 4-point module, the status of the first 4 I/O points are real world outputs and their operating status will be displayed. The 4 higher references cannot be used as real world outputs, but can be assigned to internal coils. The 4 monitor LEDs normally assigned to the 4 higher references in this group will always be OFF.

The status of an 8 point module (for example, 030 to 037) is indicated by the first 8 LED's (AND, OR, STR, . . . SR) and the next module's status, if an 8 point (for example, 040-047) will be indicated by the last 8 LEDs (MCS, MCR, SHF. . . 7). In the case of a 16-point module, the status of all 16 points will be consecutively displayed (030 to 037 and 130 to 137)). Note that this is the only valid 16-point reference that can be used with a Series One Junior PC.

5. Depressing the NXT or PRV keys will cause the address display to increment or decrement to the next or previous group of 8 statuses or module, if in an expansion rack. All discrete references can be examined. The display returns to zero after the highest reference has been examined.

MONITOR TIMER OR COUNTER STATUS — This operation sequence allows an operator to monitor the current accumulated value of a timer or counter. After installing the programmer, place the mode switch in the RUN position. Observe or perform the following actions:

1. The programmer will display the address zero indicated by four zero digits in the display, with decimal points to the right of each digit (0.0.0.0.), and the ADR LED lit.
2. Enter the timer or counter reference to be monitored. For example, to monitor the operating status of timer 601, enter SHF, 6, 0, 1). If a counter had been assigned reference 601, you would then be monitoring the status of counter 601. The valid references for timers or counters are 600 to 624. The high speed counter reference is 624. References 620, 621, 622, and 623 are reserved for future use. Remember, each valid reference can be assigned to only 1 timer or 1 counter.
3. Select the Monitor function (MON). Note that the shift selected in the previous step is still in effect causing the RST key to select the monitor function. If the selected reference is not used in the program, error code E01 will be displayed.
4. The display will contain the current content (accumulated value) of the selected timer or counter. Timer values will be displayed in tenths from 000.1 up to 999.9 and counter values will be 0001 to 9999. The Logic Display will also show the two least significant digits of the timer or counter reference (for example, 01 for timer or counter 601).
5. The NXT and PRV keys move the display to adjacent timer or counters. Any timer or counter not actually used in the logic cannot be displayed.

DISPLAY A SPECIFIC ADDRESS — This operation sequence allows you to select and display a specific memory address (location) and the logic content of that address. After installing the programmer, place the mode switch in the RUN or PRG position. Observe or perform the following actions:

1. The programmer will display the address zero indicated by four zero digits in the display, with decimal points to the right of each digit (0.0.0.0.), and the ADR LED lit.
2. Enter the memory address to be observed. For example, if the logic contained in address 36 is to be observed, SHF, 3 and 6 would be selected.
3. The NXT key is then selected and the display will contain the selected address. To display the content of this memory address, the NXT key is depressed a second time.
4. At any time, selecting SHF then NXT will cause the display to go to address 0.0.0.0.

FORCING I/O REFERENCES — The operation sequences described in this paragraph allow you to force an Input or Output reference either on or off. Forcing the state of I/O references provides a convenient method of testing the operation of field devices and debugging the logic in the user program. If an input or output is forced on or off, it will remain in the forced state for 1 scan of the CPU. The programmer must be in the RUN mode to force I/O. After installing the programmer, place the mode switch in the RUN position. Perform the following to force I/O references.

1. The programmer will display address zero indicated by four digits in the display, with decimal points to the right of each digit (0.0.0.0.), and the ADR LED lit.
2. Enter one of the following sequences to force an I/O reference either on or off as required:
 - To force a specific I/O reference ON, enter the sequence:
SET, SHF, XXX (I/O reference), ENT
 - To force a specific I/O reference OFF, enter the sequence:
RST, SHF, XXX (I/O reference), ENT
3. Repeat the above operation for other I/O references to be forced.

WARNING

WHEN FORCING INPUT POINTS WITH THE SET SEQUENCE, WHICH FORCES THE INPUT TO THE ON STATE, THE PHYSICAL STATE OF THE INPUT MAY BE OVERRIDDEN. IF THE FORCED SET OCCURS IN THE USER LOGIC PROGRAM BEFORE THE INPUT IS CHECKED IN THE SAME I/O SCAN, THE SET STATE WILL TAKE PRECEDENCE AND COULD CAUSE AN OUTPUT TO BE TURNED ON AT THE WRONG TIME.

OPERATION WITH PERIPHERAL DEVICES

Several peripheral devices are available for use with the Series One Junior PC. The Programmer is required for operation with the tape recorder, when recording user programs. The tape recorder connects to the Programmer through the Programmer's tape port. The tape port is located to the right of the mode switch and is labeled TAPE. The rest of this chapter describes the operation of these peripherals, which are listed below:

Audio Tape Recorder	Various models
Printer Interface Unit	Catalog Number IC610PER151
Plug-on PROM Writer	Catalog Number IC610PER154

TAPE RECORDER OPERATION

Most audio tape recorders with auto-level control can be used with the Series One Junior PC. It is recommended that the recorder also be equipped with a counter to allow multiple programs to be recorded on tape. Units such as General Electric model 3-5158A have been tested and found fully compatible with the Series One Junior. The tape recorder allows three functions to be performed: (1) record a program onto tape, (2) load a CPU or peripheral from tape, and (3) verify the content of a tape. The operation of each of these functions is described below in a step-by-step manner. All 700 words of logic memory are recorded on tape.

A 2.5 foot (0.75 meter) audio cable (Catalog number IC610CBL151), which is gray with a red tracer, is supplied with the programmer. This cable is used only with a tape recorder and connects it to the tape port on the programmer. A solid gray cable is supplied with the stand-alone Printer and the stand-alone PROM Writer for connecting those devices to the tape port.

Recording A Program

1. Install the Programmer and apply AC power to the Series One Junior PC.
2. Turn the mode switch on the Programmer to the LOAD position.
3. Apply AC power to the tape recorder. Verify presence of the write protect tab on a cassette and insert the cassette. If the write protect tab is not in place, data entered on the tape may be inadvertently erased.
4. Adjust the tone control to its highest position.
5. Connect the Programmer (TAPE port) to the tape recorder (MIC input) with the 2.5 ft (0.75 m) audio cable (gray with red tracer).
6. Rewind tape to the beginning or to the desired record position if multiple programs are to be placed on one tape. Programs require approximately 1.5 minutes (700 words) of tape per program.
7. For identification of a program, if desired, enter a four digit number (0000-9999) on the Programmer. When tape is accessed later to load the CPU, this number can be used to identify the correct program prior to altering CPU data. If a program number is not as expected, the operator can terminate the load operation and get the correct tape without loss of existing program nor delay incurred by loading a wrong program. However, this identification number is optional.

8. Begin the tape recorder operation by depressing the RECORD button (and PLAY if required by the tape recorder).
9. Depress the WRITE key on the Programmer. The record operation will now begin.
10. If after following all instructions, reliable operation cannot be obtained, try operating the recorder with batteries.
11. When the record is complete, the Programmer will display End in the Address/Data display and the ON/OFF LED will be off. Stop the recorder and note the counter position so that the amount of tape used for that program can be determined.
12. Depress the CLR (Clear) key on the Programmer to end the record operation.
13. It is recommended that the tape be rewound to where the record began and that the Verify operation described below be performed to ensure data integrity.

Verifying A Program

1. Install the Programmer and apply AC power to the Series One Junior PC.
2. Turn the mode switch on the Programmer to the LOAD position.
3. Apply AC power to the tape recorder and insert the cassette containing the program to be verified.
4. Adjust the tape recorder's volume control to the maximum setting. Adjust the tone control to its highest setting.
5. Connect the Programmer (TAPE port) to the tape recorder (EAR input) with the audio cable (gray with red tracer).
6. Rewind the tape to the beginning of the previously recorded program. The tape can also be on the blank area prior to the program, but not on another program. Enter the program identification number (if previously recorded).
7. Depress the CHECK key on the Programmer to select the verify operation.
8. Start the tape recorder by depressing the PLAY button. The verify operation now begins.
9. Any errors detected during the verify operation are indicated by an error code being displayed on the Programmer's Address/Data display. Error code E21 indicates that the tape has an internal parity error. E25 indicates a mismatch between the content of the tape and the CPU logic memory. E28 indicates that the play level is wrong and the verify operation should be stopped, volume adjusted, and the operation restarted (from step 6 above).

10. Setting of the volume control is critical for proper operation. The error code displayed for an incorrect (low) volume control setting is E28. Figure 4.4 illustrates the area of the volume control available for a proper setting.

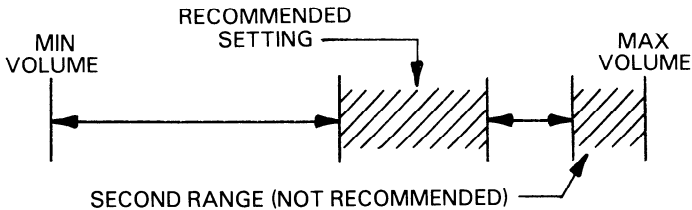



Figure 4.4 VOLUME CONTROL RANGE SETTING

With some recorders, there are two ranges where the signal level appears to be acceptable, one near the middle and one near maximum volume. The setting near maximum volume should not be used. The CPU will indicate that it is acceptable; however, an unacceptable amount of clipping distortion may occur in this area with some recorders.

11. Find the correct position for the mid-range of the acceptable volume control during the beginning or header portion of the tape. Some experimenting may be necessary. The duration of time for the header is about 12 seconds. It is important to choose the lower of the two ranges for the volume control setting if they both exist (see 10 above). For the recommended General Electric recorder this is at about 80% of the full maximum setting. Mark the proper setting with paint or some other method of identification.
12. If the volume control has been correctly set before the end of the header, the programmer display will be blank, and the lower right number 7 LED will turn on dimly. Before the end of the header the LED will turn off. A few seconds later, F will be displayed, indicating that the program has been found.
13. During the adjusting process in 11 above, the data from the tape may not be valid if the adjustment is not performed quickly enough. The tape loading should be repeated with the correct volume control setting. To clear the CPU to restart the loading, it is necessary to either power-down the CPU or remove the Programmer from the CPU, then reattach and depress the Clear key.
14. When the verify is complete without error, the Programmer will display End in the Address/Data display.
15. Stop the recorder and depress the CLR (Clear) key on the Programmer to end the verify operation.
16. The verify operation will require approximately the same time as the record operation, which is about 1.5 minutes.

Loading A Program

1. Install the Programmer and apply AC power to the Series One Junior PC.
2. Turn the mode switch on the Programmer to the LOAD position.
3. Apply AC power to the tape recorder and insert the cassette containing the required program.
4. Adjust the volume control to the setting determined during the verify operation. Adjust the tone control to its highest setting.
5. Connect the Programmer (TAPE port) to the tape recorder (EAR input) with the audio cable (gray with red tracer).
6. Rewind the tape to the beginning of a previously recorded program. Tape can also be on the blank area prior to the program, but not on another program. Enter the program identification number (if previously recorded).
7. Select the READ key on the Programmer to establish the load operation.
8. Start the tape recorder by depressing the PLAY key. The load operation now begins.

If the CPU detects a program number different than the one entered in step 6, the programmer will beep and the display will show PA .

9. If the wrong program has been selected, the load operation can be aborted by stopping the recorder and powering-down the CPU or remove the programmer from the CPU, then reattach and depress the CLR key.
10. Any errors detected during the load operation are indicated by an error code being displayed on the Programmer's Address/Data display. Error code E21 indicates the tape has an internal parity error. A steady E28 indicates the play level is wrong and the load should be stopped, volume adjusted, and the operation restarted (step 6 above).
11. When the load is complete with no errors, the Programmer will display End in the Address/Data display and the ON/OFF LED will be off. Stop the recorder and depress the CLR (Clear) key on the Programmer to end the load operation.
12. The load operation will require approximately the same time as the record operation, which is about 1.5 minutes.

PRINTER INTERFACE UNIT

The Printer Interface Unit (catalog number IC610PER151) provides an interface between the Series One Junior PC and a printer for the purpose of providing a convenient means of obtaining a hard-copy printout of the program residing in the PC's user memory. It can also be used with a Series One PC. The format of the printout is switch selectable and can be either Boolean (mnemonic) or ladder diagram format. Many readily available, inexpensive printers, including those commonly used with personal computers can be used with the Printer Interface Unit for the printout.

A 6' (2m) Printer Interface cable and an external power supply cable are included with the Printer Interface Unit. Printer Interface Unit Specifications are listed below in Table 4.4

Table 4.4 PRINTER INTERFACE UNIT SPECIFICATIONS

Operating Temperature	0° to 60° C (32° to 140° F)
Storage Temperature	- 10° to 70° C (14° to 158° F)
Humidity (non-condensing)	5 to 95%
Required Operating Power	+ 5 V dc \pm 5%, 300 mA (minimum) (Supplied either internally from the CPU or from an external power supply)
Dimensions	5.7" x 4.7" x 1.5" (145 x 120 x 38mm)
Weight	11.68 oz (330 g)
Printer Interface	Centronics (Parallel)
Printing Capacity (maximum)	Ladder Diagram Listing 13 contacts and 1 coil per line 16 lines per page Boolean Listing 200 steps per page (4 lines with 50 steps in each line). 700 steps maximum

Table 4.5 lists the requirements that a printer must meet for use with the Printer Interface Unit.

Table 4.5 PRINTER REQUIREMENTS

- Must have a Centronics interface
- Capable of generating ASCII character code 7C H (Hexadecimal) as a " / ".
- Must respond to control codes:
 - 0E H (SO) — Expanded print ON
 - 0F H (SI) — Compressed print ON
 - 12 H (DC2) — Compressed print OFF
 - 14 H (DC4) — Expanded print OFF
- Must be capable of printing 132 columns; however, if an 80 column printer can respond to the SI (0F H) control code to allow 132 or more characters per line, it can be used. This type of printer, when used with the Printer Interface Unit, will print compressed characters. A choice of either normal (132 column) print or compressed (80 column) print is switch selectable.

- The following printers have been tested for operation and can be used with the Printer Interface Unit.

General Electric Personal Computer Printer, model 3-8100
 Epson model RP-100
 Hewlett Packard Thinkjet, model HP 2225C
 IBM Personal Computer Graphics Printer
 Seiko model GP-500

HARDWARE DESCRIPTION

The Printer Interface Unit is a self-contained unit that attaches to the Series One Junior PC. Electrical and physical connections to the PC are made through a 26-pin connector, located on the back of the Printer Interface Unit. The Printer Interface Unit is attached to the PC by placing its 26-pin connector directly over the mating connector on the PC and gently pushing down on the unit until it is securely in place.

Connection from the Printer Interface Unit to the selected printer is made through the Printer Interface Cable, IC610CBL152A to a 24-pin connector on the front of the unit. Power to the unit can be supplied directly through the rear panel connector from the CPU power supply or from an external power source capable of supplying + 5 V dc @ 300 mA. The power source, either internal (INT) or external (EXT) is selected by a 2-position switch located on the rear panel. Connection to an external power source is made through a 3-wire cable supplied with the Printer Interface Unit.

The sequence for operation of the Printer Interface Unit is initiated by depressing pushbutton switches on the front panel. Two indicator lights on the front panel provide a visual status of the Printer Interface Unit operation. There are also 2 indicators that provide operating status of the PC. Figure 4.5 is an illustration of the Printer Interface Unit showing the features mentioned above.

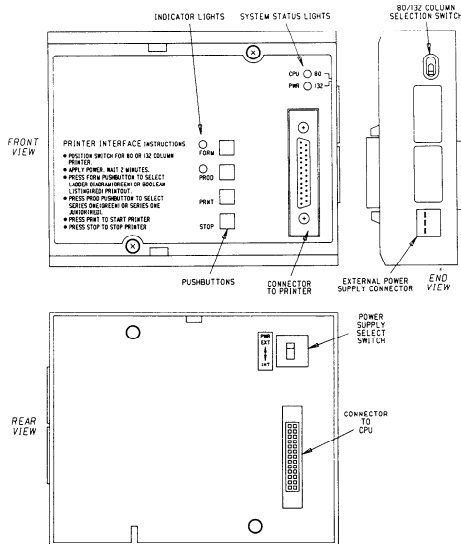

Figure 4.5 FRONT, SIDE, AND REAR VIEWS OF PRINTER INTERFACE UNIT

HARDWARE FEATURES

The Printer Interface Unit front panel has two LEDs located in the upper right corner used for visual indication of system status. The purpose of the indicators is described below.

CPU	The red CPU LED is an indication of the status of the CPU in the PC. This is identical to the CPU LED on the Series One Junior.
ON	CPU failure has been detected.
OFF	CPU operation is normal.
PWR	The green PWR LED is an indication of the status of dc power being supplied to the Printer Interface Unit.
ON	If power is being supplied by the Series One Junior's internal power supply, this indicates that +5 V dc is being produced by the supply. If the Printer Interface Unit is being powered from an external source, the +5 V dc being supplied is within the specified tolerance.
OFF	5 V dc not being supplied or not in tolerance.

The 24-pin connector located on the lower right of the front panel, provides a connection from the Printer Interface Unit to the selected printer through the Printer Interface cable, IC610CBL152A.

Immediately to the left of the connector are 4 pushbuttons used to initiate operation of the Printer Interface Unit to get a hard copy printout. There are also 2 LEDs used as status indicators during the set-up procedure

FORM	<p>This pushbutton is used to select the format of the printout, either a ladder diagram or Boolean listing of the user program. The pushbutton is an alternate function switch. Each time it is depressed, the selected printout format will change.</p> <p>As the pushbutton is depressed, the color of the LED will alternate between green and red. The LED, when green, indicates a ladder diagram printout; when red, indicates a Boolean listing printout.</p>
PROD	<p>This pushbutton is also an alternate function switch. Each time it is depressed, either a Series One Junior or Series One PC is alternately selected as the program listing source. The selection must agree with the PC to which the Printer Interface Unit is attached.</p> <p>As this pushbutton is depressed, the color of the LED will alternate between green and red. The LED, when red, indicates selection of Series One Junior; when green, indicates selection of Series One.</p>
PRNT	When depressed, this pushbutton causes the printer to begin printing the user program in the selected formats.
STOP	When depressed, this pushbutton causes the printing operation to stop.

80/132 COLUMN SELECTION SWITCH

On the right side-panel is a 2-position toggle switch used for selection of either 80 column printing format (compressed print) or 132 column printing format (normal print). The 80 column compressed print format is typically used with printers designed for use with personal computers. The selected printer column format corresponding with the switch position is printed on the right edge of the front panel, either 80 (towards the top of the unit) or 132 (towards the bottom of the unit). If desired, the 80 column compressed print format can be selected for use with a 132 column printer. The unused space to the right, beyond the 80th column, could be used for adding comments.

EXTERNAL POWER SUPPLY CONNECTOR

A connector located on the lower right side of the unit provides the connections to an external power supply. A mating 3-pin connector with attached wires which are 3 feet (1m) in length, is provided with the Printer Interface Unit for connection to the external supply. The color code for the external power supply cable and specifications for the power supply are as follows:

White	+5 V dc, \pm 5% (rated at 300 mA minimum)
Black	Power supply logic ground
Green	Common system ground

POWER SUPPLY SELECT SWITCH

This is a two-position switch located on the bottom of the unit, directly above the 26-pin connector. This switch is used for selection of either internal or external dc power for the Printer Interface Unit. The top switch position is labeled EXT (External) and the bottom position is labeled INT (Internal). When used with a Series One Junior, the Printer Interface Unit should be powered by an external +5 V dc power supply and the Power Supply Select switch set to EXT.

SEQUENCE OF OPERATION

As a convenience to the user, instructions for using the Printer Interface Unit are printed on the front panel of the unit. The sequence of operation is described below.

POWER-UP SEQUENCE

The following power-up sequence should be followed after the Printer Interface Unit has been properly configured.

1. Power to be supplied by an external power supply.
2. Place EXT/INT switch in the EXT position.
3. Turn off power to the Series One Junior PC.
4. Mount Printer Interface Unit onto the PC.
5. Attach Printer Interface cable from connector on front panel of unit to printer.
6. Turn on power to the Series One Junior PC.
7. Turn on power to the external power supply.

USER PROGRAM TRANSFER FROM PC TO PRINTER INTERFACE UNIT

Immediately after the power-up sequence has been completed, the user program stored in the PC's user memory will automatically begin transferring to a buffer memory in the Printer Interface Unit. This program transfer will take about 1.5 minutes. When the program has been successfully transferred, the FORM and PROD LED indicators will turn on green. If the program transfer is not successful, the LED indicators will either flicker on and off red or neither LED will illuminate. If after 2 minutes, neither LED turns on, repeat the power-up procedure from the beginning of the sequence.

SELECTION OF PRINTOUT FORMAT AND TYPE OF PC.

Select the printout format, either ladder diagram or Boolean, and the PC model, either Series One Junior or Series One, by depressing the FORM and PROD switches as shown in the following table.

Table 4.6 FORMAT AND PC SELECTION

FORM		PROD	
PRINTOUT TYPE	LED ON	PC	LED ON
Ladder	Green	Series One	Green
Ladder	Green	Series One Junior	Red
Boolean	Red	Series One	Green
Boolean	Red	Series One Junior	Red

START PRINTER OPERATION

Depress PRNT pushbutton. The ladder diagram or Boolean program listing will begin to print and continue printing until the complete program has been listed or has been stopped by the operator.

If at any time, the program listing is to be stopped, depress the STOP switch. When this is done during a ladder diagram printout, the printout will stop. When the STOP switch is depressed during a Boolean listing printout, the Boolean listing printout will stop, the printer will formfeed, and the complete OUTPUTS USED TABLE will be printed in its entirety.

PRINTING OF ERROR MESSAGES DURING LADDER DIAGRAM LISTING.

If any errors in the printing process are detected by the Printer Interface Unit during printing of a ladder diagram listing, an error message will be printed and the printing may stop, depending on the type of error. Table 4.7 lists the error messages and their definitions.

Table 4.7 LADDER DIAGRAM LISTING ERROR MESSAGES AND DEFINITIONS

ERROR MESSAGE	DEFINITION
ROW OVER COLUMN OVER STACK ERROR (SR)	One rung of logic exceeds 16 lines. More than 13 circuit elements in line Clock or Reset line not programmed in Shift Register logic.
STACK ERROR (CNT)	Reset line not programmed in Counter logic.
STACK OVER	Pushdown stack using AND STR and OR STR functions exceeds 8 levels.
STACK OVER (MCS)	Levels of MCS control exceed 8.
MC ERROR	MCR functions exceed MCS functions.
PROGRAM ERROR	Any error not listed in this table.

NOTE

When the ROW OVER or COLUMN OVER error messages are printed, the printout of the ladder diagram will continue. When any of the other error messages are printed, a PRINT STOP message will be printed, the paper will feed and the printing operation will stop.

PRINTING OF ERROR MESSAGES DURING BOOLEAN LISTING

If any errors in the printing process are detected by the Printer Interface Unit during printing of a Boolean program listing, an error message will be printed and the printing may stop, depending on the type of error. Table 4.8 lists the Boolean listing error messages and their definitions.

Table 4.8 BOOLEAN LISTING ERROR MESSAGES AND DEFINITIONS

ERROR MESSAGE INSTRUCTION OPERAND	DEFINITION
ERROR	Not a valid instruction
???	Incorrect operand

CROSS REFERENCE PRINTOUT

When the ladder diagram or Boolean printout of the user program listing has been completed, the printer will formfeed and then begin to print a cross reference printout of all outputs. The heading of this printout is, OUTPUTS USED TABLE. The outputs referenced in the user program (real world outputs, internal relays, shift registers and timers/counters) will have an annotation mark to the right of the reference number.

The OUTPUTS USED TABLE will continue printing until all output references have been printed. This printout cannot be stopped, as can the ladder diagram and Boolean listing printouts.

EXPANDED PRINT FORMAT

When a more complex ladder diagram, using MCS and MCR functions, is to be printed out, an expanded print format is used. The starting point of each MCS function is denoted by a letter, the first is A, then B, etc. The letter is carried through to the end of each page and the beginning of the next page, providing a ready reference to the continuation of the ladder logic within the bounds of each MCS/MCR control. As multiple MCS functions and the logic under their control are printed, each succeeding group of logic is shifted to the right. When a group of logic under MCS/MCR control is ended by an MCR function, (MCR) is printed in the last column to the right and the letter corresponding to that MCS/MCR logic to its right.

PRINTOUT ANNOTATION EXPLANATION

Several items appearing on the printouts in Figures 4.6 and 4.7 are explained for clarification. The ladder diagram printout in Figure 4.6 has a circled number (1-5) next to each annotation, which corresponds to the number preceding the explanation of each annotation. The circled number 6 appears before an annotation on the Boolean printout in Figure 4.7. The circled numbers (1-6) are for discussion purposes only and do not normally appear on a printout.

- ① The type of printout on each page appears on this line, either LADDER DIAGRAM PRINTOUT, BOOLEAN PRINTOUT, or CROSS REFERENCE PRINTOUT.
- ② This annotation, V X.X, is the version of the system operating software contained in PROM memory in the Printer Interface Unit.
- ③ The model of PC selected by the user as the program listing source will be on this line. The annotation will be either SERIES ONE JR/SR-10 for a Series One Junior PC or SERIES ONE/SR-20 for a Series One PC.
- ④ The page number of the ladder diagram printout or Boolean printout will appear here as a 4-digit decimal number, starting with PAGE 0001.
- ⑤ Refers to ladder diagram printout only. This 4-digit decimal number is the user program memory address at the start of each rung of logic. The first element in the rung is stored at that address. In the example in Figure 4.6, the memory address of the start of the first rung is 0000. The first element in that rung is a normally open contact referenced as 000 (reference number is printed directly above the contact). The memory address at the start of the second rung is 0014, the first element in this rung is a normally open contact referenced as 010.
- ⑥ Refers to Boolean printout only (Figure 4.7). The # sign immediately preceding a numerical value in the Boolean printout listing, indicates that the value is a reference assigned to an element at the end of a rung.

Additional explanation for annotation not shown on the examples.

Boolean printout for Series One Junior only. An (E) preceding a Timer or Counter reference (620, 621, 622 or 623) indicates that the reference is for a Timer or Counter having preset values provided by an external thumb-wheel unit. A (Z) precedes the built-in High Speed Counter reference, 624.

SAMPLE PRINTOUT

Sample of each of the previously described printouts is shown in the following group of figures. For this group of printouts, a simple program was entered into the Series One Junior PC.

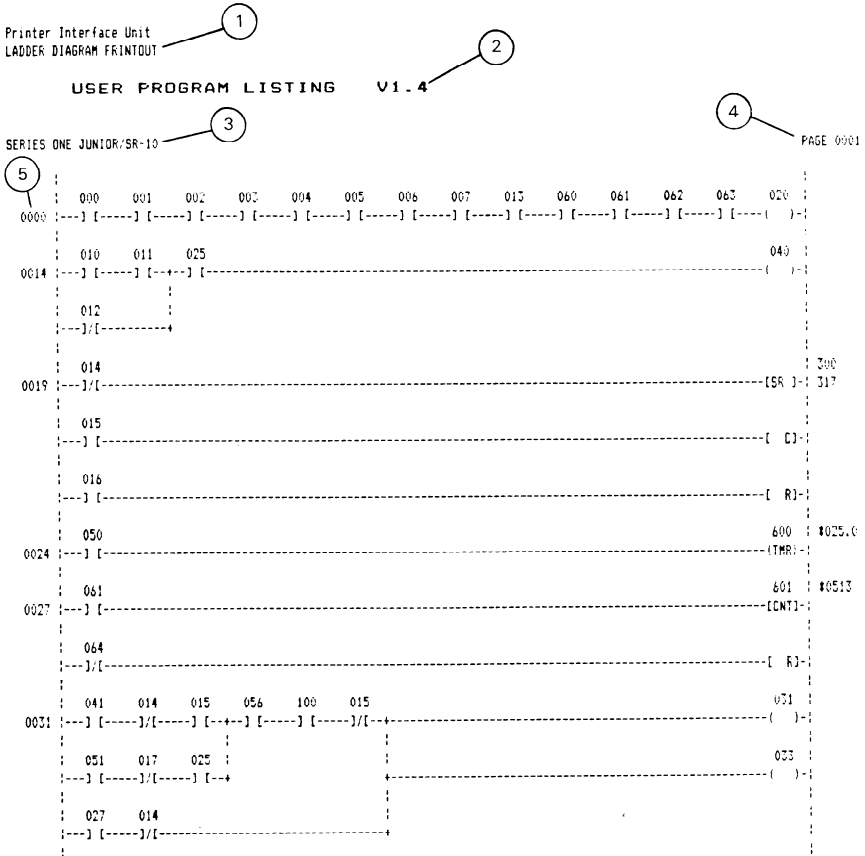

Figure 4.6 SAMPLE LADDER DIAGRAM PRINTOUT

Printer Interface Unit
 BOOLEAN PRINTOUT

USER PROGRAM LISTING V1.4

SERIES ONE JUNIOR/SR-10

PAGE 0001

0000: STR	000	0050: -	0100: -	0150: -
0001: AND	001	0051: -	0101: -	0151: -
0002: AND	002	0052: -	0102: -	0152: -
0003: AND	003	0053: -	0103: -	0153: -
0004: AND	004	0054: -	0104: -	0154: -
0005: AND	005	0055: -	0105: -	0155: -
0006: AND	006	0056: -	0106: -	0156: -
0007: AND	007	0057: -	0107: -	0157: -
0008: AND	013	0058: -	0108: -	0158: -
0009: AND	060	0059: -	0109: -	0159: -
0010: AND	061	0060: -	0110: -	0160: -
0011: AND	062	0061: -	0111: -	0161: -
0012: AND	063	0062: -	0112: -	0162: -
0013: OUT	# 020	0063: -	0113: -	0163: -
0014: STR	010	0064: -	0114: -	0164: -
0015: AND	011	0065: -	0115: -	0165: -
0016: DR NOT	012	0066: -	0116: -	0166: -
0017: AND	025	0067: -	0117: -	0167: -
0018: OUT	# 040	0068: -	0118: -	0168: -
0019: STR NOT	014	0069: -	0119: -	0169: -
0020: STR	015	0070: -	0120: -	0170: -
0021: STR	016	0071: -	0121: -	0171: -
0022: SR	# 300	0072: -	0122: -	0172: -
0023: -	317	0073: -	0123: -	0173: -
0024: STR	050	0074: -	0124: -	0174: -
0025: IMF	# 800	0075: -	0125: -	0175: -
0026: -	#025.0	0076: -	0126: -	0176: -
0027: STR	061	0077: -	0127: -	0177: -
0028: STR NOT	064	0078: -	0128: -	0178: -
0029: CNT	# 601	0079: -	0129: -	0179: -
0030: -	# 0513	0080: -	0130: -	0180: -
0031: STR	041	0081: -	0131: -	0181: -
0032: AND NOT	014	0082: -	0132: -	0182: -
0033: AND	015	0083: -	0133: -	0183: -
0034: STR	051	0084: -	0134: -	0184: -
0035: AND NOT	017	0085: -	0135: -	0185: -
0036: AND	025	0086: -	0136: -	0186: -
0037: DR STR		0087: -	0137: -	0187: -
0038: STR	056	0088: -	0138: -	0188: -
0039: AND	100	0089: -	0139: -	0189: -
0040: AND NOT	015	0090: -	0140: -	0190: -
0041: AND STR		0091: -	0141: -	0191: -
0042: STR	027	0092: -	0142: -	0192: -
0043: AND NOT	014	0093: -	0143: -	0193: -
0044: DR STR		0094: -	0144: -	0194: -
0045: OUT	# 031	0095: -	0145: -	0195: -
0046: OUT	# 033	0096: -	0146: -	0196: -
0047: -		0097: -	0147: -	0197: -
0048: -		0098: -	0148: -	0198: -
0049: -		0099: -	0149: -	0199: -

Figure 4.7 SAMPLE BOOLEAN PRINTOUT

Printer Interface Unit
CROSS REFERENCE PRINTOUT

OUTPUTS USED TABLE V1.4

SERIES ONE JUNIOR/SR-10

OUTPUT

000:	010:	020: ‡	030:	040: ‡	050:
001:	011:	021:	031: ‡	041:	051:
002:	012:	022:	032:	042:	052:
003:	013:	023:	033: ‡	043:	053:
004:	014:	024:	034:	044:	054:
005:	015:	025:	035:	045:	055:
006:	016:	026:	036:	046:	056:
007:	017:	027:	037:	047:	057:

060:	070:	100:	110:	120:	130:
061:	071:	101:	111:	121:	131:
062:	072:	102:	112:	122:	132:
063:	073:	103:	113:	123:	133:
064:	074:	104:	114:	124:	134:
065:	075:	105:	115:	125:	135:
066:	076:	106:	116:	126:	136:
067:	077:	107:	117:	127:	137:

INTERNAL RELAY

140:	150:	160:	170:	200:	210:	220:	230:	240:	250:
141:	151:	161:	171:	201:	211:	221:	231:	241:	251:
142:	152:	162:	172:	202:	212:	222:	232:	242:	252:
143:	153:	163:	173:	203:	213:	223:	233:	243:	253:
144:	154:	164:	174:	204:	214:	224:	234:	244:	254:
145:	155:	165:	175:	205:	215:	225:	235:	245:	255:
146:	156:	166:	176:	206:	216:	226:	236:	246:	256:
147:	157:	167:	177:	207:	217:	227:	237:	247:	257:

260:	270:	300: ‡	310: ‡	320:	330:	340:	350:	360:	370:
261:	271:	301: ‡	311: ‡	321:	331:	341:	351:	361:	371:
262:	272:	302: ‡	312: ‡	322:	332:	342:	352:	362:	372:
263:	273:	303: ‡	313: ‡	323:	333:	343:	353:	363:	373:
264:	274:	304: ‡	314: ‡	324:	334:	344:	354:	364:	374:
265:	275:	305: ‡	315: ‡	325:	335:	345:	355:	365:	375:
266:	276:	306: ‡	316: ‡	326:	336:	346:	356:	366:	376:
267:	277:	307: ‡	317: ‡	327:	337:	347:	357:	367:	377:

Figure 4.8 SAMPLE OUTPUTS USED TABLE PRINTOUT

Printer Interface Unit
CROSS REFERENCE PRINTOUT

OUTPUTS USED TABLE V1.4

SERIES ONE JUNIOR/SP-10

TIMER/COUNTER

600: ‡	610:	620:
601: ‡	611:	621:
602:	612:	622:
603:	613:	623:
604:	614:	624:
605:	615:	
606:	616:	
607:	617:	

Figure 4.9 SAMPLE OUTPUTS USED TABLE PRINTOUT
(CONTINUED)

PROM WRITER UNIT

The plug-on PROM Writer unit (catalog number IC610PER154) is a compact, easy to use device that connects directly to and mounts on a Series One Junior or Series One PC. When mounted on the Series One Junior, the PROM Writer unit is used to write the contents of user memory to a 2732A-2 PROM, thereby providing a non-volatile means of user program storage. After being written to, the PROM can be installed in any Series One Junior PC as required. Programs stored in PROM memory will not be lost during no-power conditions.

An additional feature of PROM memory is that different programs can be stored on individual PROMS for use as required by various applications. Another function of the PROM Writer unit is to transfer the user memory contained in a PROM to the CMOS memory in a Series One Junior.

On the Series One Junior, the PROM Writer unit physically mounts on the lower left of the front panel, in the same manner as the programmer. A connector on the lower left rear of the PROM Writer unit attaches to the connector on the lower left of the front panel on a Series One Junior. When used with a Series One Junior, the PROM Writer unit *must* be powered by an external power supply. The source of power for the PROM Writer unit is switch selectable. Figure 4.10 is an illustration of the PROM Writer showing the location of its features, which are described in the text following the illustration.

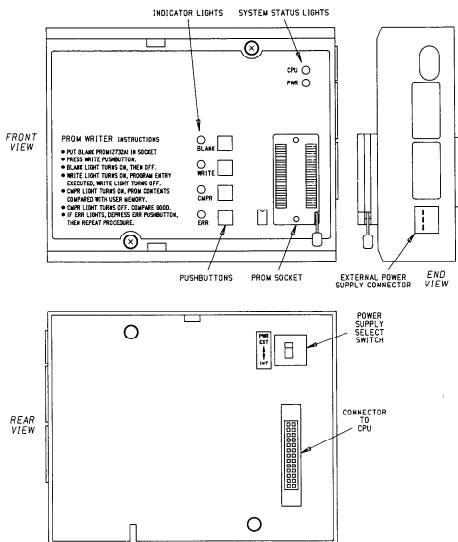

Figure 4.10 PLUG-ON PROM WRITER UNIT FEATURES

FRONT PANEL FEATURES

The front panel has two LEDs in the upper right corner which are visual indicators of system status. The purpose of the each indicator is described below.

PWR	The green PWR LED monitors the status of dc power being supplied to the PROM Writer unit.
ON	If power is being supplied by the CPU rack, this indicates that +5 V dc is being produced by the supply. If the PROM Writer unit is being powered from an external source, the +5 V dc being supplied is within the specified tolerance.
OFF	5 V dc not being supplied or not in tolerance.
CPU	The red CPU LED monitors the operating status of the CPU module. Identical to the CPU LED on the Series One Junior or a Series One CPU module.
ON	CPU failure has been detected.
OFF	CPU operation is normal.

The socket on the lower right of the panel is used to contain the PROM being written to. The socket is a zero insertion force socket. To insert a PROM into the socket, push the locking handle up, insert the PROM, then lock the PROM in place by moving the handle down to the horizontal position. The PROM should be placed in the socket with the notch towards the end of the socket closest to the PWR LED as indicated by the figure on the panel next to the socket. Even though the spacing of the slots in the socket allows easy insertion of a PROM, care should be taken to ensure that leads on the PROM are not damaged.

Immediately to the left of the socket are 4 pushbuttons and their associated LED indicators. These pushbuttons are used to initiate operation of the PROM Writer unit and the LEDs are indicators for each part of the operation.

BLANK	When depressed, initiates checking of the PROM inserted in the socket for verification that the PROM does not have any information written into it. To initiate a blank check, the pushbutton is depressed. The light will turn on, then off, indicating a successful blank check. If the light remains on, and the ERR light turns on, the PROM needs to be erased. The BLANK light will also turn on, then off during the normal operation of writing to a PROM as indicated by the instructions printed on the lower left of the unit.
WRITE	When depressed, the WRITE pushbutton initiates the sequence of events that causes the user program in the Series One Junior CMOS memory to be written to the PROM. When the WRITE pushbutton is depressed, the BLANK light will turn on, then off. Next, the WRITE light turns on, program entry is executed, then the WRITE light turns off. A blank check and verify are performed automatically when the WRITE push-

- CMPR** During the sequence for writing to a PROM, this light will turn on while the contents of the PROM are being compared to the contents of user memory in RAM. The CMPR light turns off when the compare is completed and is good. If the compare is not good, the CMPR light will remain on and the ERR light will turn on. In addition, the contents of a PROM inserted in the PROM Writer unit socket can be compared to the contents of user memory, whenever the CMPR pushbutton is depressed.
- ERR** This light is a visual indication that the PROM writing operation has not been successful. If the light turns on during any portion of the operation, an error has occurred. If this does happen, depress the ERR pushbutton and repeat the procedure.

As a convenience to the user, the PROM Writer unit instructions for writing the contents of user memory to a PROM are printed on the lower left of the unit.

SEQUENCE OF OPERATION

The sequence of operation for writing the contents of user RAM memory to PROM memory is as follows:

WRITE OPERATION SEQUENCE	INDICATION
Depress WRITE pushbutton	WRITE light turns on
Blank check performed	WRITE light turns off BLANK light turns on
Write to PROM	BLANK light turns off WRITE light turns on
Verify contents of PROM with contents of RAM memory	WRITE light turns off CMPR light turns on
Write sequence successful	CMPR light turns off

The sequence of operation for transferring the contents of PROM memory to CMOS memory is as follows (the CMOS memory should be cleared first):

PROM TO RAM OPERATION SEQUENCE	INDICATION
Depress WRITE and CMPR pushbutton at the same time. Contents of PROM will be transferred to RAM memory in the PC.	WRITE light and CMPR light will turn on.
Contents of PROM and RAM memory are compared.	WRITE light turns off.
Compare good. Sequence of operation complete.	CMPR light turns off *

*If an error is detected during the compare operation, the CMPR light will remain on and the ERR light will turn on. The error can be cleared by depressing the ERR pushbutton. When this is done, the ERR and CMPR lights will turn off. If an error is indicated, repeat the operation.

EXTERNAL POWER SUPPLY CONNECTOR

A connector located on the right side of the PROM Writer unit provides the connections to an external power supply. A mating 3-pin connector with attached wires 3 feet (1 m) in length, is provided with the PROM Writer unit for connection to the external supply. The color code for the external power supply cable and specifications for the power supply are as follows:

White	+ 5 V dc, \pm 5% (rated at 0.5 amps)
Black	Power supply logic ground
Green	Common system ground

POWER SUPPLY SELECT SWITCH

This is a two-position switch located on the bottom of the PROM Writer unit, directly above the 26-pin connector. The switch is used for selection of either internal or external dc power for the PROM Writer unit. The top switch position is labeled EXT (External) and the bottom position is labeled INT (Internal). When used with the Series One Junior, the PROM Writer unit *must* be powered by an external + 5 V dc power supply and the Power Supply Select Switch set to EXT. When used with a Series One PC mounted in a high-capacity rack, power can be supplied internally and the Power Supply Select Switch is set to INT.

TIMER/COUNTER SETPOINT UNIT

The Timer/Counter Setpoint Unit (IC609TCU100) provides an alternative method of entering a preset value for a timer or counter. A Timer/Counter Setpoint Unit mounts on a Series One Junior basic unit and plugs into the same connector as does the hand-held programmer. The Timer/Counter Setpoint Unit can also be connected remotely by using the 5 foot (1.5m) remote programmer cable, IC610CBL102. With the unit mounted on the PC, the hand-held programmer can then be mounted on top of the Timer/Counter Setpoint Unit, thereby providing a convenient way to monitor the operation of timers or counters. The physical size of the unit is the same as the Data Communications Unit, Printer Interface Unit and the PROM Writer Unit.

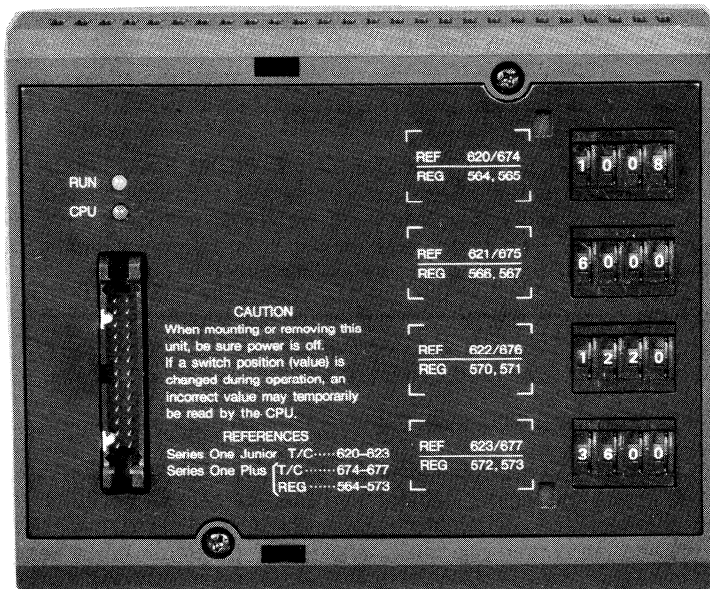

Figure 4.11 TIMER/COUNTER SETPOINT UNIT

There are four 4-digit thumbwheel switches on the unit, which provides a convenient means of entering a 4-digit BCD value into each of 4 specific internal locations in the Series One Junior PC for use as Timer/Counter preset values. When the BCD preset values have been entered into the PC, they are retained in the PC's memory as presets, even though power is removed from the PC and the unit is removed.

TIMER/COUNTER SETPOINT UNIT SPECIFICATIONS

The following table contains general specifications for the Timer/Counter Setpoint Unit.

Table 4.9 TIMER/COUNTER SETPOINT SPECIFICATIONS

Number of Circuits	4 (4 BCD digits per circuit)
Timer/Counter References	620, 621, 622, 623
Preset Values	Timer: 0.1 to 999.9 seconds Counter: 1 to 9999 events
Ambient Temperature	0° to 50°C (32° to 122°F)
Storage Temperature	-20° to 85°C (-4° to 185°F)
Humidity (non-condensing)	5% to 95%
Operating Power	Supplied internally from the PC
Environment Considerations	No corrosive gases

REMOTE MOUNTING OF TIMER/COUNTER UNIT

A Unit Mounting Bracket, IC61 0ACC1 90, is available which allows mounting of the Timer/Counter Setpoint Unit on the outside of a panel or console. The Unit Mounting Bracket consists of a mounting bracket, connector clamp and a cable clamp. The Timer/Counter Setpoint Unit mounts on the bracket, secured by two captive screws on the unit. The unit connects to a Series One Junior PC through the round 5 foot (1.5m) remote programmer cable, IC61 0CBL1 02.

REFERENCES FOR THE TIMER/COUNTER SETPOINT UNIT

The Timer/Counter references for the memory locations into which the BCD values are entered in the Series One Junior are 620, 621, 622 and 623. Each of the references refer directly to a memory location in the CPU that accepts one 4-digit BCD value as it is entered with each 4-position thumbwheel switch. Each thumbwheel position represents one BCD digit, with the least significant digit being the position to the right.

Since all four BCD values are read into the PC each scan, discretion must be exercised when changing any values when the PC is running, since undesired intermediate values could be read by the CPU and used during one or several scans. It is recommended that the following CAUTION be followed.

CAUTION

WHEN MOUNTING OR REMOVING THE TIMER/COUNTER SETPOINT UNIT, BE SURE THAT POWER IS TURNED OFF. IF A SWITCH POSITION (VALUE) IS CHANGED DURING OPERATION, AN INCORRECT VALUE MAY TEMPORARILY BE READ INTO THE CPU.

EXAMPLE OF USING THUMBWHEEL INPUTS

The following example of a ladder diagram rung shows how the Timer/Counter Setpoint Unit is used to enter a preset value into a Timer.

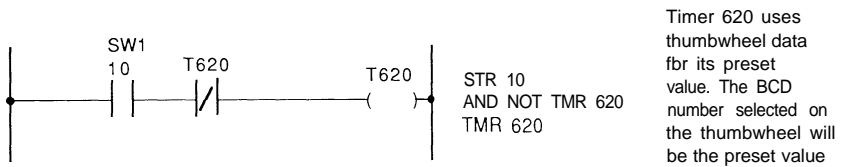

Figure 4.12 EXAMPLE OF LADDER LOGIC FOR TIMER/COUNTER SETPOINT UNIT

CHAPTER 5 PROGRAMMING

INTRODUCTION

One of the advantages of any PC is its ability to be programmed or tailored specifically to the needs of an application. If the application requirements change, the PC can be reprogrammed to fit the new application. This chapter provides the information needed by a user in order to develop or modify the logic within the Series One Junior. Discussions in this chapter include the basics of CPU operation necessary to develop a proper logic program, the theory behind each function, examples of how that function can be used, and step-by-step entry of sample programs.

PROGRAMMING REFERENCES

Whenever programs are entered into any PC, they must contain reference numbers. These references help to tell the CPU what exact function is desired. For example, which pushbutton controls the starting of which motor? Which timer are you referring to? Which step of the sequencer do you want this output on? Reference numbers are a vital part of programming. In the Series One Junior, the reference numbers are octal based. They start at 0 and go up to 7, then jump to 10; after 77 the next value is 100. They look like traditional decimal numbers, except the digits 8 and 9 are not used. Table 5.1 summarizes the various reference values and their significance in the Series One Junior .

Table 5.1 PROGRAMMING REFERENCES

REFERENCE	OCTAL VALUE	DECIMAL QUANTITY
I/O Points		96 total
Basic Unit Inputs	000-016	15
Basic Unit Outputs	0 17-027	9
Expansion Unit Inputs	030-047	16
Expansion Unit Outputs	050-06 1	10
Expansion Rack I/O	030-1 37	72
Internal Coils		160 total
Non-Retentive	140-277	96
Retentive	300-372	59
Set Retentive Coils	373	1
First Scan Reset	374	1
0.1 Second Clock	375	1
Disable All Outputs	376	1
Back-up Battery Status	377	1
Shift Register	140-372	155 (total steps)
Timers and Counters	600-623 *	20 (4 digit)
High Speed Counter	624	1
Sequencers	600-623	20 (1000 step)

*Timer and Counter references 620, 621, 622, and 623 are reserved for use with the Timer/Counter Setpoint unit.

INPUT/OUTPUT REFERENCES

References assigned to inputs and outputs for the basic Series One Junior PCs are fixed for each unit. Those are the only valid references and are marked on the unit adjacent to each field wiring terminal. There are a total of 15 inputs and 9 outputs for each basic unit. If the I/O requirement for a system is greater than 24, an expansion unit or expansion rack can be added. Expansion units have up to 26 I/O points, allowing a total of 50 in a system. An expansion rack connected to a basic unit can have up to 72 I/O, providing a system total of 96 I/O. The valid I/O references for an expansion rack are listed in Table 5.1. The assignment of I/O references to inputs or outputs in an expansion rack depends on the type of module, either input or output, placed in each of the I/O slots.

USE OF INTERNAL COILS

The internal coils are control relays used to control logic in the user program in the Series One Junior PC; however, their status cannot be provided directly to the I/O section. Retentive relays are specialized internal coils that have their ON or OFF status retained during time periods that the PC is not operating such as during loss of AC power. They use dual operations (set or reset) similar to hard-wired latching relays.

USE OF THE SPECIAL PURPOSE COILS

Internal coils 373 through 377 are special purpose coils, in that they will always perform specific internal functions and provide useful internal status. Reference 373 must be programmed into user memory address 0000 using a SET 373 or an OUT 373 instruction in order to specify internal coils 300-372 as retentive coils. If this is not done, the internal coils 300-372 will be non-retentive. Coil 374 is a first scan reset or power-up indicator. Coil 375 provides a convenient method of programming a 0.1 second clock pulse. Coil 376 can be used to inhibit all hardware outputs, that is, outputs connected to user devices (programmed with an OUT XXX instruction). Coil 377 is an indicator of the status of the back-up battery.

SHIFT REGISTER REFERENCES

The next group of references are used by the shift register. A total of 155 steps are possible. Notice that the shift register references include both the non-retentive coils (140 to 277) and the retentive coils (300 to 372). They can be used as one large shift register or a group of smaller shift registers (for example, 4 with 30 steps, 1 with 25 steps and 1 with 10 steps) as long as the total number of steps does not exceed 155.

TIMER AND COUNTER REFERENCES

The references 600 to 623 are reserved for use with timers and counters. References 620, 621, 622, and 623 can only be used with the Timer/Counter Setpoint unit. Any mix of timers or counters totaling 20 can be used in any Series One Junior PC. Counters can also be programmed to control up to 20 sequencers each having up to 1000 steps. Counters are retentive upon power failure. The reference 624 is a special one, in that it is reserved specifically for the built-in high speed counter.

FLEXIBILITY IN USING REFERENCES

Although references are assigned to specific functions as shown in Table 5.1, there is flexibility in their use. I/O references not used by the hardware I/O section (for example, no module inserted into a slot in an expansion rack or circuit not wired up) can be used as internal coils. If expansion is planned for the future, sufficient references to support that expansion should be reserved and not used in the current programming. Retentive coils can also be used as internal coils if their retentive function is not required. However, typically the unique value of retentive relays does not justify their sacrifice for a few internal coils.

CPU OPERATING PRINCIPLES

Before discussing the details of programming and how to use the references, some details on the internal operation of the CPU can be useful. The majority of Series One Junior applications can be solved and programs developed without consideration of the internal structure of the CPU. However, some applications can be more efficiently solved if knowledge of the CPU operation is applied while the program is being developed. The basic operation of all PCs is referred to as a scanning function. There are hundreds of decisions to be performed in any program, and the CPU can not do all of them simultaneously. Similar to any electronic processor, it does things one at a time. However, the speed of performance internally, makes the external results appear to have all operations accomplished at once.

CPU SCANNING

The term scan is a method of describing how the CPU performs its assigned tasks (see Figure 5.1). It begins at the first function, such as a relay contact, entered into the beginning of memory (address 0000). It proceeds sequentially through all memory addresses performing all functions entered by the user (for example relay contacts, timers, latching relays, counters, sequencers, shift registers, etc.) until it reaches either the end of memory (address 0700) or the end of the program as entered by the user.

During the scan the logic sets or resets coils, according to the logic program entered by the user. The status of these coils is immediately available to the next logic function. At the end of the logic scan, the CPU gets input data from the input modules and provides new data to output modules. Then, the programmer if connected, is serviced by making logic changes and/or updating its display. After servicing the programmer, the CPU performs a check of its internal hardware and resets the watchdog timer. The watchdog timer is a hardware timer set at 100 ms (milliseconds) to ensure that memory or internal circuit faults do not cause the CPU to enter an endless loop because of hardware failure. If a scan is not completed at least once every 100 ms (typical scan time for 700 words is 40 ms), the hardware will shut the CPU down and turn the outputs OFF.

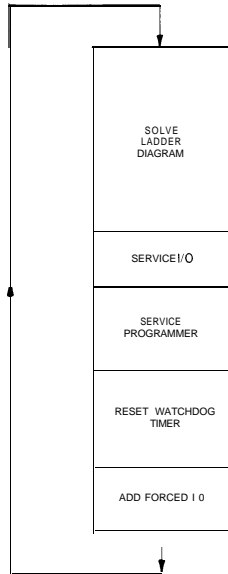

Figure 5.1 CPU SCANNING SEQUENCE

Finally, any forced I/O will be entered. With successful completion of the internal checks, the CPU goes back to the start of the scan and continues its scan at address 0000. This repetitive scanning operation is performed as long as power is applied and the CPU is in the RUN mode.

The scanning operation is basic to PC operation and should not be overlooked. It provides a very useful verification of the CPU's reliability. The scanning operation also provides a fixed and definable sequence of logic decisions. Functions are solved in the order programmed and the results of one function (for example, coil, timer, shift register, etc.) are immediately available internally to the next logic element.

PROGRAMMING THE SERIES ONE JUNIOR

The basic programming language for the Series One Junior is a simple relay ladder representation based upon standard Boolean (mnemonic) functions (AND, OR, and NOT). Throughout the discussion of programming, examples will be used to illustrate the function just described. The illustration of the hand-held Programmer in Figure 5.2 can be used as a reference while going through the examples. Specific key sequences are illustrated so that the user can enter and demonstrate the example. A short-hand notation is also provided, which is recommended as an easy method to document your program. A complete discussion of the programmer is provided in Chapter 4; however, a brief overview of important keys is presented here to improve the user's understanding of the examples.

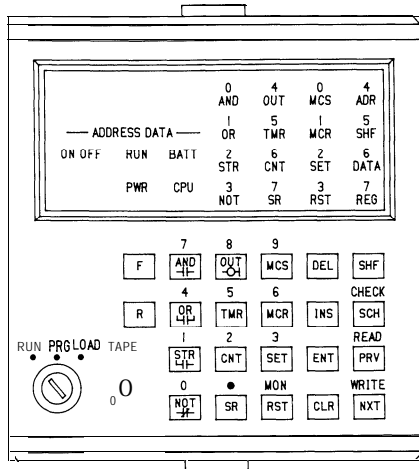

Figure 5.2 PROGRAMMER

PROGRAMMER KEYS

The keyboard has both upper and lower case functions similar to a typewriter. The numerical keys are accessed by first selecting the SHF (Shift) key located in the upper right. Once depressed, the SHF LED is lit (display center right) and then the appropriate numerical digit(s) can be selected. The shift function is latched and will be released only by selection of an ENT (Enter) or CLR (Clear) key. The SHF key does not have to be held. The display window in the upper left reflects either address or data information (not both) as the operation progresses. Typically, as keys are selected, their respective LEDs will light to display the function selected. The F and R keys on the IC610PRG105 programmer are not used by the Series One Junior. Other frequently used keys are as follows:

KEY	FUNCTION
AND	Place referenced status in series (AND) with previously entered logic.
OR	Place referenced status in parallel (OR) with previously entered logic.
STR	STaRt new rung of a ladder diagram.
NOT	NOT or invert (make normally closed) the referenced contact.
OUT	OUTput logic status to a coil, either real-world output or internal coil.
TMR	Selects a TiMeR function.
CNT	Selects a CouNTER function.
SET	SET latching relay or shift register status.
MCS	Master Control Start — begin control of master control relay.
MCR	Master Control Reset — end control of master control relay.
SR	Shift Register — selects a shift register function.
RST	ReSeT a latching relay or shift register status.

BASIC LADDER DIAGRAM FORMAT

Figure 5.3 illustrates 2 rungs of a typical ladder diagram. Between two vertical power rails to the extreme left and right, contacts are placed in horizontal strings or lines. Adjacent lines can be connected between contacts by a vertical line to allow logic to be solved in parallel. The horizontal strings (series) of contacts are equivalent to ANDs. For example, the first line can be described as A and B and C must occur before coil X is energized. Any one reference can prevent the coil from energizing. Similarly, vertical contacts are in parallel and programmed as ORs. The second line is described as D or E or F, and will energize coil Y. Any one reference by itself can energize coil Y. In the Series One Junior, there is no internal limit on how many contacts can be placed in series, nor how many in parallel. However, as a practical limit for ease of programming and system documentation, it is recommended that a horizontal string be limited to nine contacts and a vertical array to seven parallel lines.

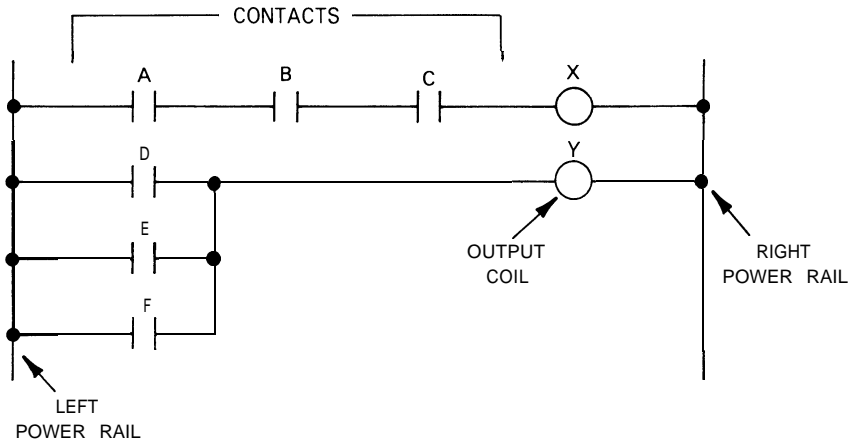

Figure 5.3 BASIC LADDER DIAGRAM FORMAT

CONCEPT OF POWER FLOW

A key operating feature of PCs is power flow. This is a conceptual flow of electrons used to visualize the operation of coils, timers and counters, etc. Referring again to Figure 5.3, the left hand power rail can be envisioned as "hot" (connected to 115 or 230 V ac) and the right as its associated "neutral" (connected to 115 or 230 V ac return). Coils (for example, X and Y) will be energized (turned ON) if there is a path for electrons to flow from the left leg to the coil placing the full potential across the coil. If there is no power (electron) flow, the coil will be de-energized (OFF).

Power always flows from the left towards the right and will pass through normally open contacts if their references are energized (ON) or normally closed with de-energized (OFF) references. Power flow is also allowed vertically either up or down between adjacent lines where parallel connections are programmed. However, power can NOT flow from right to left at any time through contacts or horizontal shunts. This feature simplifies programming and prevents undesired sneak paths. However, if hard wired relays are replaced by a Series One Junior, it is possible some adjustments may be necessary to the logic to either simplify the programming or to add sneak paths that may be a basis for the relays functioning.

UNLIMITED REFERENCES

Another difference between PC programming and hardwired relays is that any reference such as an input or coil can be used as relay contacts as often as necessary. Since references are merely a unique series of bits in a word of memory, they can be programmed wherever and whenever necessary. With PCs, there is no need to count relay contacts and try to limit individual references to four or less contacts. There is no need to plan to use form C relay configurations to squeeze two contacts from one pole. Any reference can be envisioned as a relay controlling many poles providing both normally open and normally closed contacts that operate without any time delay from pole 1 (closest to the coil) to pole 1,000 (furthest away from coil).

DEVELOPING THE PROGRAM

The first step when developing a PC system should be to define the system by writing a description of the system functional requirements. A description would typically consist of block diagrams and written descriptions of the various components of the system. Input devices should be defined along with outputs for the process or machines to be controlled.

The next step would be to develop the program required to control the system. On a sheet of paper, layout each rung of the ladder diagram and assign references to inputs and outputs. The program can also be written in mnemonic form (Boolean), which is how it will be keyed-in when entering the ladder diagram logic using the Programmer with the Series One Junior.

PROGRAMMING FUNCTIONS

Table 5.2 shows the programming functions available for use when programming your Series One Junior PC system. In addition to the function name (STR, AND, AND NOT, etc.), the symbol for that function is illustrated. The use of and how to enter each of these functions is detailed in this chapter.

FUNCTION	SYMBOLOLOGY	FUNCTION	SYMBOLOLOGY
STR		RST	
STR NOT		MCS	
AND			
AND NOT			
OR			
OR NOT			
AND STR			
OR STR		CNT	
OUT		SR	
SET			
SET OUT			

Table 5.2 PROGRAMMING FUNCTIONS

HOW TO BEGIN PROGRAMMING

The easiest way to begin feeling comfortable with programming the Series One Junior PC, is to enter one rung of logic with contacts in series that control a single coil. Connect input devices (pushbutton switches, limit switches, etc.) and an output device (such as a lamp) to the corresponding terminals on the Series One Junior PC, turn the inputs on and off, and observe the result on the output device.

ENTERING A RUNG WITH SERIES CONTACTS

In the following program sequence, a rung of ladder logic is shown, then the keystroke sequence required for entering the logic. Notice that when entering a numerical sequence, the SHF key must be depressed before the number or number sequence. In the example, each keystroke is separated by a comma. Numbers with more than 1 digit are grouped together for ease of interpretation.

Turn the mode keyswitch to the PROG (programming) position in order to enter the logic.

Enter two normally open contacts (1 and 2) in series controlling the state of an output coil (17). Both contacts must be closed to turn on the output.

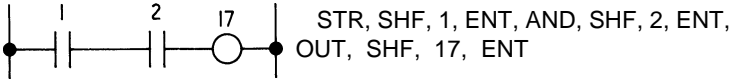

When input devices wired to inputs 1 and 2 are closed, output 17 will turn on. The operating state of the inputs and outputs, either ON or OFF, can be monitored by observing the LEDs on the Programmer's logic display that correspond to the input or output.

ENTERING THE CLEAR ALL MEMORY SEQUENCE

After observing the operation of the series rung, the rung can be deleted by entering the clear all memory sequence, or the rung can remain in memory, with the next rung starting at the next memory address. The next memory address, assuming that the above rung was entered at address 0000, is 0003.

If you wish to clear the contents of memory and start the next rung at address 0000, enter the following key sequence

CLR, SHF, 348, DEL, NXT

When the clear all memory sequence has been successfully entered, the rung of logic that had been entered will be cleared from memory. Remember, whenever the clear all memory sequence is entered, the entire contents of memory will be cleared. Be sure that you want to clear the complete contents of memory when using this sequence, there is no recovery.

ENTERING A RUNG WITH PARALLEL CONTACTS

Continue the simple program entry by entering a normally open contact (4) in parallel with a second normally open contact (20) that references the output coil (20). In series with these, add a normally closed contact (5), then the output coil.

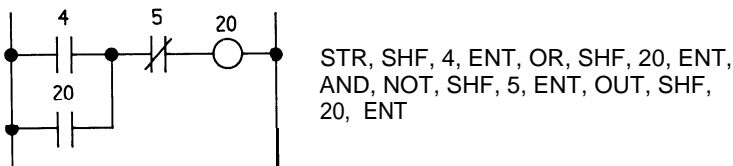

If an input device, such as a limit switch is wired to input 4, and the limit switch is closed, the output would turn on. The normally open contact referencing the output would close and become a seal contact, which would maintain the output in the on state, even if the limit switch wired to input 4 were then opened. The output could be turned off, in this example, by momentarily closing a switch connected to the closed contact, reference 5. Since this is a normally closed contact, it would open when the switch is depressed, and the output would turn off. This logic is commonly used as a motor starter.

ENTERING A SIMPLE TIMER RUNG.

Enter two rungs of logic, the first ending with a timer, having a preset value of 30 seconds. The second rung has an output controlled by the state of the timer coil. When input 11 is closed, the timer begins timing up from 0 towards the preset value of 30 seconds. When the accumulated value of the preset reaches 30, the timer coil will turn on, contact T605 will close, and output 25 will turn on.

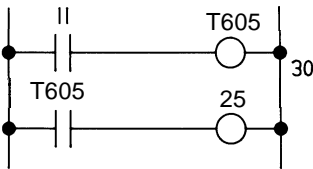

STR, SHF, 11, ENT, TMR, SHF, 605, ENT,
 SHF, 30, ENT
 STR, TMR, SHF, 605, ENT, OUT SHF,
 25, ENT

BASIC RELAY LOGIC (MOTOR STARTER)

With this background on the basics of Series One Junior programming, Figure 5.4 is an example to further illustrate relay ladder programming. In this example, selected keys, LED status and what is seen on the display are included in the illustration. The references used were selected purely for illustrative purposes and can be adjusted as necessary to meet your application needs. This is a simple motor starter and seal circuit with field wiring connected to a basic Series One Junior PC. Input reference 005 is connected to a start pushbutton, and input reference 006 is connected to a stop pushbutton. For the output, reference 010 is an output to a motor starter. The program does not care whether these input and output modules are 115 V ac or 24 V dc. The STR (Start) key begins a new rung of logic. This example and most that follow assume an empty memory, so the example begins at address 0000.

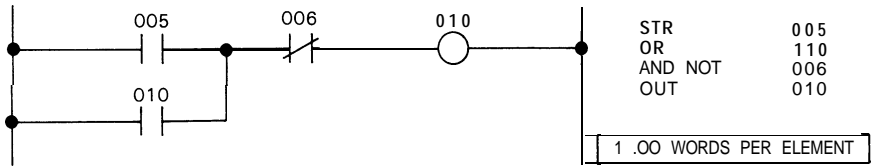

KEY	ON LED'S	DISPLAY	KEY	ON LED'S	DISPLAY
STR	STR		AND	AND	
SHF	STR, SHF		NOT	AND, NOT	
5	STR, SHF	5	SHF	AND, NOT, SHF	
ENT	ADR	0.0.0.1	6	AND, NOT, SHF	6
OR	OR		ENT	ADR	0.0.0.3
SHF	OR, SHF		OUT	OUT	
1	OR, SHF	1	SHF	OUT, SHF	
0	OR, SHF	IO	1	OUT, SHF	1
ENT	ADR	0.0.0.2	0	OUT, SHF	IO
			ENT	ADR	0.0.0.4

Figure 5.4 SAMPLE RELAY LOGIC (MOTOR STARTER)

MOTOR STARTER LOGIC DESCRIPTION

The first reference is entered (STR, SHF, 5, ENT) and a normally open contact is established since the NOT key was not depressed. Referring to Figure 5.4, the next function moving from the left (contact 005) to the right along the top line of the logic rung, is a parallel contact referenced as 010. Parallel logic is represented by the OR function, which is selected, followed by SHF, then the desired reference (10) and the Enter key to load it into memory. Again moving to the right of the top line, the next contact is in series with the logic completed so far, therefore, the AND key is selected (for series logic). Since this contact is normally closed, the NOT key is also selected followed by SHF, the reference 6 and the Enter key.

The final element of this logic is the coil or output of the rung. Selecting the Output key does not ensure that a "real world" output will be generated. It must also include an I/O reference and have a physical output corresponding to that reference. To establish the rung output coil, the output key is selected followed by the Shift key, the reference (IO) and the Enter key. Outputs can be paralleled by entering additional OUT functions immediately after the initial one.

NORMALLY CLOSED INPUT

After completing the logic of Figure 5.4, several features of programming should be noticed. First, all elements of the program are entered directly into CMOS memory as the Enter (ENT) key is depressed. Thus, if power should be interrupted while a program is being entered or altered, the program will be totally saved, except possibly for the one element being worked on. Second, there is feedback on the programmer for all entries. Something happens (LED ON, display changes, error codes appear, etc) each time a key is selected. Third, the logic is set up for inputs that are wired normally open. If an input is wired normally closed, an adjustment must be made to the symbol (NO or NC) used for that input. Referring to Figure 5.5, inputs sense voltage at their field terminals. They can not detect if a voltage is from a normally open limit switch that is depressed or from a normally closed pushbutton that is not depressed. Cover up the two field devices wired to inputs 002 or 003. If you were the input module, and both applied voltage to the field terminals, could you tell which was wired normally closed or which was normally open? Because of this, the programmer or system designer must compensate when programming or designing the system.

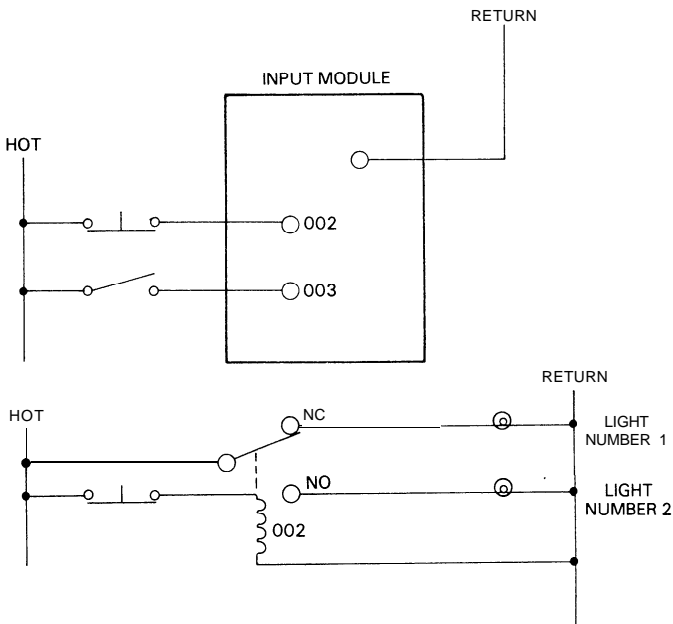

Figure 5.5 EXAMPLE OF NORMALLY CLOSED INPUTS

In a previous discussion it was stated that inputs are like relays with many poles and you are selecting which type of pole is to be used when you program. In the lower half of Figure 5.5, coil 002 is shown in the de-energized position; however it is wired to a normally closed pushbutton. When you want power to flow if the pushbutton is NOT depressed, which contact type do you choose, NO or NC? The answer is normally open, since coil 002 is always energized except when the pushbutton is depressed. Therefore, in programming the Series One Junior, a normally open contact is appropriate. If the stop button of Figure 5.4 were wired normally closed, its internal logic should be normally open to compensate. However, this concept does not normally cause problems for the programmer. Since PCs are easily reprogrammable, if an error is made and discovered when the system is exercised, it is easy to correct.

CONNECTING SERIES AND PARALLEL GROUPS OF LOGIC

Two very useful functions are programmed using a sequence of 2 keys, the AND STR and the OR STR. The AND STR provides a common series connection between a group of logic and the OR STR provides a common parallel connection for a group of logic. These functions provide the connecting links not possible with any of the previously mentioned functions. Figure 5.6 illustrates the use of these functions. The logic used with this type of operation is referred to as a push-down stack. The push-down stack can accommodate up to eight levels (groups) of logic. A push-down stack can be thought of as a temporary storage area to allow the combining of elements in series (AND) or parallel (OR) connections.

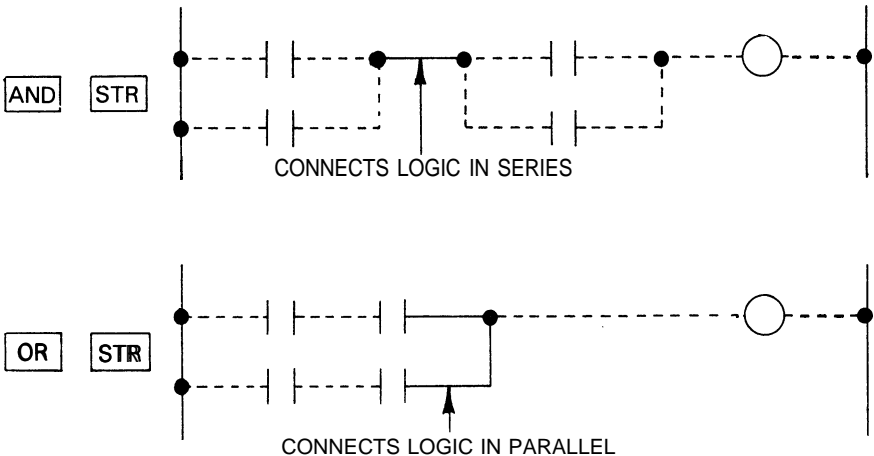

Figure 5.6 AND STR and OR STR CONNECTIONS

An example of a more complex rung of logic, in Figure 5.7, illustrates how logic is connected using the AND STR and OR STR in the same rung. The keystroke sequence for entering the logic is shown. The connecting lines and blocks to the right show how the contacts are connected by the AND STR and OR STR.

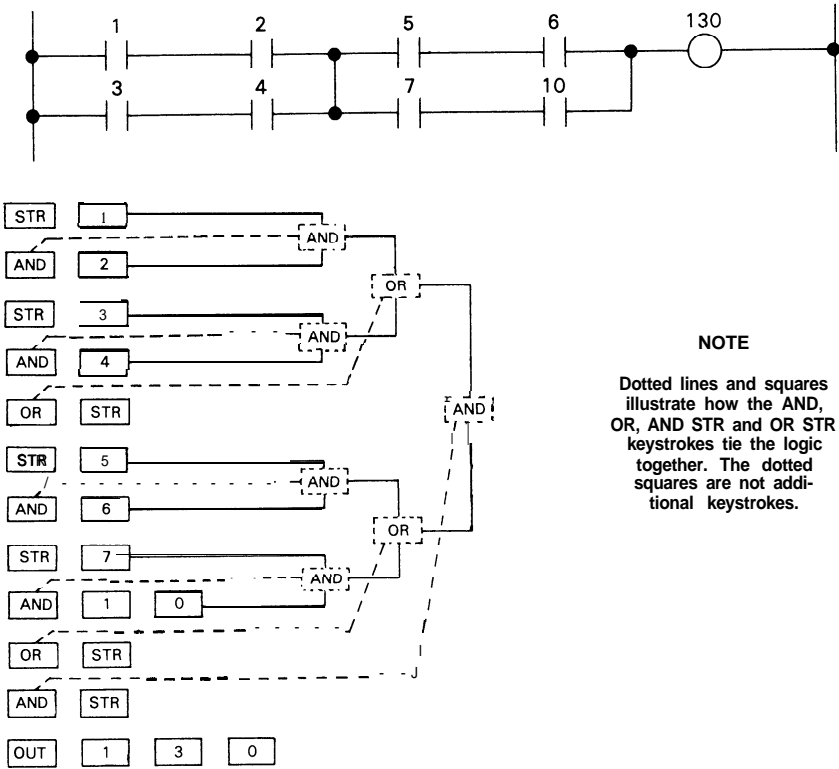

Figure 5.7 PROGRAMMING THE AND STR and OR STR INSTRUCTIONS

USE OF RETENTIVE COILS AS LATCHES

All of the coils used in the programming examples so far are not retentive upon power failure. If a non-retentive coil is ON when power is removed from the CPU, it will be OFF when power is reapplied. There are 59 special coil references (300-372) that can be programmed to be retentive on power failure. These coils provide 2 valuable functions, they allow the contents of user memory to be retained after loss of power and they allow latching functions to be programmed. In order for those coils to be retentive, reference 373 must be programmed into address 0000, using either a SET 373 or OUT 373 instruction. If this is not done, coils 300 - 372 will function as non-retentive coils. If programmed to be retentive, and they were ON prior to loss of power, they will be ON when power is restored. They will be OFF while power is OFF since no scanning is being performed.

In addition to coils 300-372, the special purpose coils 373, 374, 375, 376 and 377, and timer/counter references 600 through 623, are retentive upon loss of power.

Coils specified as retentive coils by programming coil 373 can be used as control contacts, both normally open and normally closed, wherever required. This special retentive function is derived from their use as coils to complete or store the results of relay logic rungs.

PROGRAMMING A LATCHED COIL

Latches require two separate functions or inputs similar to hard-wired relays, a set (turn ON) and a reset (turn OFF). These functions are also commonly referred to as latch and unlatch. If both are active, the last one in the scan will control the state of the coil. To turn on a latch, the function SET followed by the retentive coil reference (for example, 300-372) is used rather than OUT plus the coil reference at the end of a logic rung. Once power flows to that coil, it will be energized (turned ON) and remain ON even if power flow to it should be interrupted.

To turn a latch off (de-energize), separate relay logic should be programmed ending with a RST (Reset) function and the same coil reference number. In many applications, it is useful to allow the system to clear (turn OFF) coils when power fails so that an orderly restart is possible when power is restored, whether that is 2 seconds or several hours, or several days later. Other applications require the control system to remember the status of key items such as part position, operations completed, elevators up or down, etc.

The Series One Junior is provided with both standard and retentive coils which allow you to tailor the program to fit your particular requirements,

Figure 5.8 illustrates the programming of retentive (latch) relays. Coil 340 is used only as an example. The logic to either set or reset a retentive coil can be of any convenient size similar to standard coil logic. When power flows through the top rung to the coil specified by the SET 340 function, it will be energized and remain ON even if power flow is removed. Anytime the power flows through the lower rung (regardless of path), coil 340 will be turned OFF. Since the SET 340 function is programmed before the reset, it is stored in lower memory locations and the reset function will have overriding control if they are both energized.

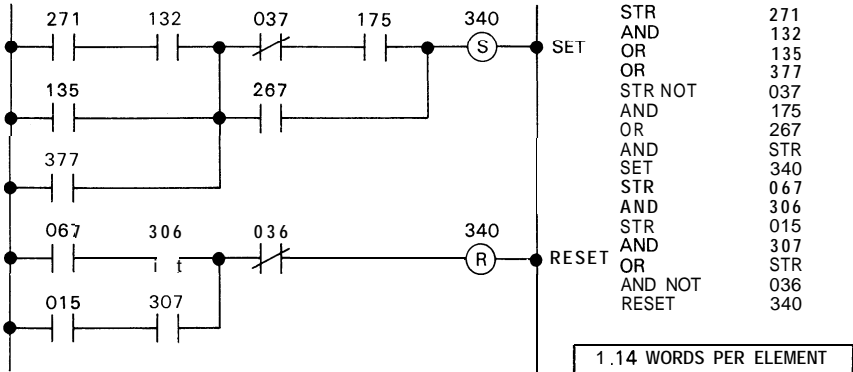

Figure 5.8 SAMPLE LATCHING LOGIC

MASTER CONTROL RELAY FUNCTIONAL DESCRIPTION

To control large quantities of coils on a supervisory basis, a Master Control relay function is provided. This function allows efficient programming for turning off large quantities of coils in case some major permissive is not satisfied. One approach would be to incorporate a permissive contact in each rung controlling one of the coils. This may require many contacts and attendant use of memory. This is wasteful of memory and inefficient. Another method is to bracket those rungs over which master control is desired. This is similar to quotation marks around a direct statement (one at each end to define exactly where the statement starts and where it ends.)

The permissive logic is first built starting to the left of the ladder diagram adjacent to the "hot" power rail. Then an MCS (Master Control Start) function is entered, followed by the logic it is to control, and ending with an MCR (Master Control Reset) function. The MCS and MCR are like quotations around the logic to be controlled. When power flows to the MCS, the logic enclosed will operate normally. If there is no power flow to the MCS, the coils will be forced to the OFF state regardless of the internal logic conditions, timers will be reset to zero, and counters will stop (frozen) but not reset. The amount of logic controlled by the Master Control function is limited only by the memory provided.

PROGRAMMING A MASTER CONTROL RELAY FUNCTION

Figure 5.9 illustrates the use of one pair of MCS/MCR functions. In many cases it is convenient to view the MCS function as defining a sub-left power rail whose connection to the main power rail is dependent upon some relay logic. The conditional logic (I003-I005 in this example) is built first using the normal relay logic. The MCS function is entered without any reference, to create the control beginning point. Logic is built using normal functions within the control area. Note the duplication of contact 052, which adds only one memory word. You do not need to count or limit the quantity of relay contacts used in PCs. To end the master control, the MCR function is entered returning control to the next power rail to the left and conventional logic can now be built. Unless both references 003 and 005 are energized (ON) in this example, coils 052, 271, and 265 will be OFF. When these contacts are passing power, coils 052, 271, and 265 will respond to their normal logic.

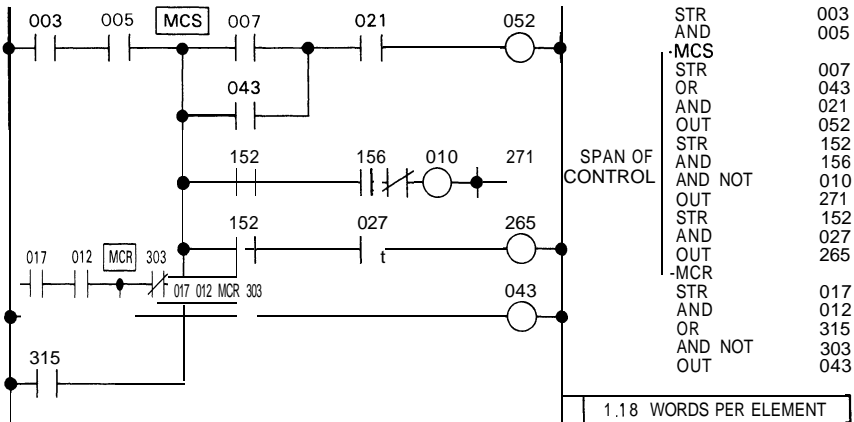

Figure 5.9 MASTER CONTROL RELAY LOGIC

MULTIPLE MASTER CONTROL RELAY FUNCTIONS

Multiple master control functions are possible in any logic program. They can be imbedded within the scope of the first MCS and the last MCR if necessary, as illustrated in Figure 5.10. The first group of coils under the master control of references 010 or 011 is 204-213 which includes two smaller groups (207-210 and 212-213). Group 207 and 210 are under the master control of 010 or 011 and 015, while group 212 and 213 are controlled by 010 or 011 and 022. Note the requirement for two successive MCRs to end both the group 212-213 and the larger group 204-213. *To operate correctly there must be an equal number of MCS and MCR functions in your program.*

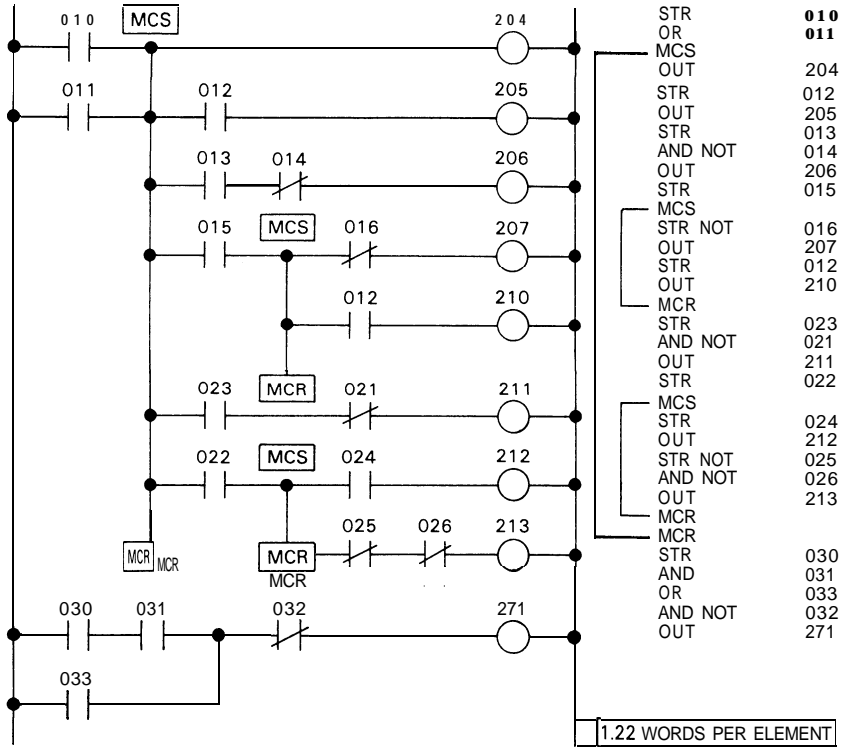

Figure 5.10 MULTIPLE MASTER CONTROL RELAY LOGIC

DISABLING OF OUTPUTS

In addition to Master Control relay functions, most outputs can be affected by a special function internal coil referenced as 376. When this coil is energized by user logic, most outputs in the hardware I/O structure will be turned OFF. Internal coils and statuses will still operate, but only internally. The only exception is to coils programmed as SET OUT functions rather than the normal OUT function. These coils can provide their normal output status (ON or OFF) to the I/O section.

Figure 5.11 illustrates the use of coil 376. In this example, when either reference 003 or 056 is energized, coil 376 will also be energized. This will cause all coils programmed with the OUT function, such as 020, to be turned OFF (no output control to physical device), although internally, they will function normally. However, coils driven by the SET OUT function, such as 021, will not be affected by the status of coil 376. Table 5.3 summarizes the effect of coil 376.

NOTE

It is not recommended that the Output Disabler coil (376) be used with retentive coils (latches).

Table 5.3 EFFECT OF COIL 376 (OUTPUT DISABLER)

INTERNAL STATUS	COIL 376 OFF		COIL 376 ON	
	OUT	SET OUT	OUT	SET OUT
OFF	OFF	OFF	OFF	OFF
ON	ON	ON	OFF	ON

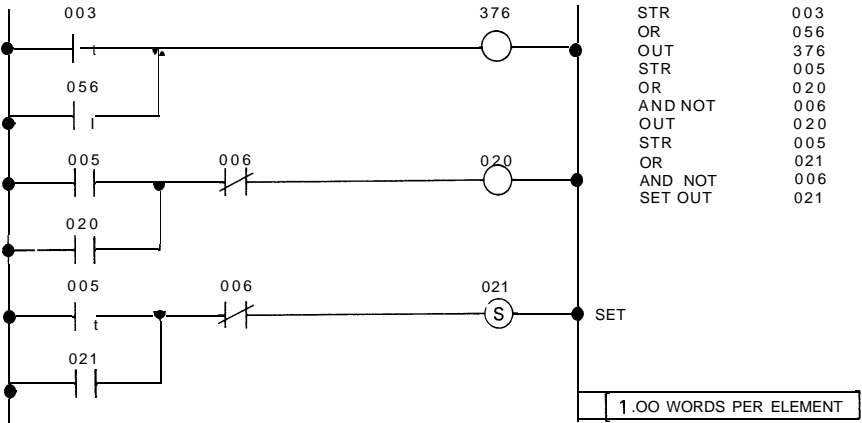

FIGURE 5.11 COIL DISABLER LOGIC EXAMPLE

TIMER AND COUNTER FUNCTIONAL DESCRIPTION

In addition to relay logic, there are a wide variety of standard functions with the Series One Junior. Timing and counting are two of the most commonly used non-relay functions. These functions are programmed by specifying special coils using references 600-623. A total of up to 20 timers and/or counters can be built within the Series One Junior. Preset values for references 620-623 can only be programmed with the Timer/Counter Setpoint unit. When programmed, timers and counters end a rung of logic similar to using an OUT function for relay logic. Unlimited contacts, both normally closed (timed OFF delay) and normally open (timed ON delay) can be referenced to any timer or counter coil. Presets are used to indicate how many seconds, tenths of seconds, or counts, the function should delay before energizing its coil. When the coil is energized, time or counts continue to be recorded. Presets can have up to four decimal digits (0001 to 9999), with timers set from 000.1 to 999.9 seconds, and counters from 1 to 9999 counts.

The four references (620-623) can not use internal presets; however, they will count up to 9999 and can be used to drive sequencers without the thumbwheel interface.

PROGRAMMING TIMERS

Timers (Figure 5.12) can be programmed in either seconds or tenths of seconds and require only one line of logic to control their operation. When power flows to the timer coil, it begins recording time at the rate of one count every 0.1 seconds. The timer starts at 000.0 and records time, towards the programmed preset value. When the preset value is reached, an event will happen according to what has been programmed. Also, when the timer reaches the preset value, the timer will continue timing up, until reset by an interruption of power flow through its conditional contacts, or until it reaches its maximum of 999.9, at which time it will stop. If power flow to a timer is interrupted or if the CPU should stop operating, the timer will be reset to zero. The basic clock driving all timers derives its accuracy from a crystal within the CPU. Timers and counters do not depend upon the AC power line frequency. A timer can be programmed to be self resetting by programming a closed contact, referencing the timer coil, as a conditional contact preceding the timer coil. If programmed in this manner, when the preset value is reached, the timer coil will turn on, the closed contact referencing the coil will open and the timer will reset to 000.0 and start counting again.

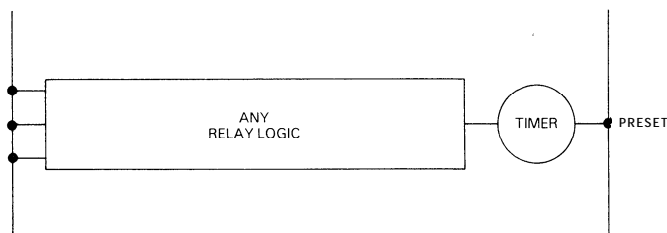
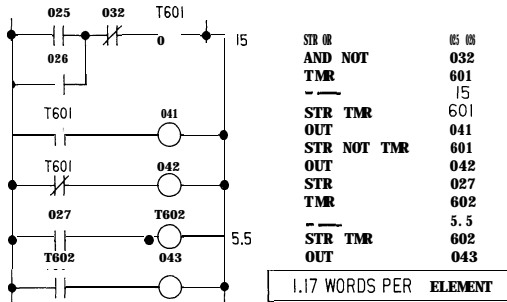

Figure 5.12 TIMER LOGIC REQUIREMENTS

Figure 5.13 illustrates the programming of various types of timers. The relay logic is built in the normal manner up to the coil selection. The timer (TMR) function is then selected along with a timer reference (600-623). Each timer must have its own unique coil to operate properly. After the timer is identified, the preset is entered. In this example, coil 41 will be OFF until 15 seconds after timer 601 is energized. It will remain ON until either the power flow to 601 is interrupted or the CPU goes through a power down operation. Coil 42 is inverted from 41 in that it stays ON until 15 seconds after power flows continuously to timer 601, when it goes OFF. Timer 602 delays 5.5 seconds after reference 27 is energized before it turns its coil ON, which in turn energizes coil 43.



KEY	ON	LED's	DISPLAY	KEY	ON	LED's	DISPLAY
[STR]	STR			[STR]	STR		
[SHF]	STR, SHF			[TMR]	STR, TMR		
[2]	STR, SHF	2		[SHF]	STR, TMR, SHF		
[5]	STR, SHF	2 5		[6]	STR, TMR, SHF		
[ENT]	ADR	0.0.0.1		[0]	STR, TMR, SHF		
[]	OR			[1]	STR, TMR, SHF		
[SHF]	OR, SHF			[ENT]	ADR		
[2]	OR, SHF	2		[OUT]	OUT		
[6]	OR, SHF	2 6		[SHF]	OUT, SHF		
[ENT]	ADR	0.0.0.2		[4]	OUT, SHF		
[AND]	AND			[1]	OUT, SHF		
[NOT]	AND, NOT			[ENT]	ADR		
[SHF]	AND, NOT, SHF			[STR]	STR		
[3]	AND, NOT, SHF	3		[NOT]	STR, NOT		
[AND, NOT, SHF]	AND, NOT, SHF	32		[TMR]	STR, NOT, TMR		
[ENT]	ADR	0.0.0.3		[SHF]	STR, NOT, TMR, SHF		
[TMR]	TMR			[6]	STR, NOT, TMR, SHF		
[SHF]	TMR, SHF			[0]	STR, NOT, TMR, SHF		
[6]	TMR, SHF	6		[1]	STR, NOT, TMR, SHF		
[0]	TMR, SHF	60		[ENT]	ADR		
[1]	TMR, SHF	601		[OUT]	OUT		
[ENT]	ADR	0.0.0.4		[SHF]	OUT, SHF		
[SHF]	SHF			[4]	OUT, SHF		
[1]	SHF	1		[2]	OUT, SHF		
[5]	SHF	15		[ENT]	ADR		
[ENT]	ADR	0.0.0.5		[STR]	STR		
				[SHF]	STR, SHF		
				[2]	STR, SHF		
				[7]	STR, SHF		
				[ENT]	ADR		0.0.1.0
				[TMR]	TMR		
				[60]	[SHF]	TMR, SHF	
				0.0.0.6	[0]	TMR, SHF	
					[2]	TMR, SHF	
					[ENT]	ADR	
					[SHF]	SHF	
					[5]	SHF	
					[0.0.0.7]	[0]	SHF
						[5]	SHF
						[ENT]	ADR
						[STR]	STR
						[TMR]	STR, TMR
						[SHF]	STR, TMR, SHF
						[6]	STR, TMR, SHF
						[60]	STR, TMR, SHF
						[601]	STR, TMR, SHF
						0.0.0.8	[2]
							[STR, TMR, SHF]
							[ENT]
							[ADR]
							[OUT]
							[OUT]
							[SHF]
							[OUT, SHF]
							[4]
							[42]
							[4]
							[OUT, SHF]
							[0.0.0.9]
							[3]
							[OUT, SHF]
							[ENT]
							[ADR]
							[0.0.1.4]

Figure 5.13 EXAMPLE OF TIMER LOGIC

PROGRAMMING COUNTERS

Counters (Figure 5.14) operate similar to timers except that they require two rungs of relay logic to control their operation. The upper rung controls when the counter is incremented. When this rung goes from no power flow to power flow (OFF to ON), the counter is incremented by one count. To cause another count to be recorded, power flow must be interrupted and another OFF to ON transition must occur. The ability to detect transitions and record counts is built into the counter function and requires no further programming by the user. The lower rung of logic (next STR function) controls resetting of the counter function. Whenever this rung supplies power flow to the counter, the counter will be reset to zero. If both rungs supply power flow, no counts are recorded and the counter is forced to zero. All counters are retentive upon loss of CPU power.

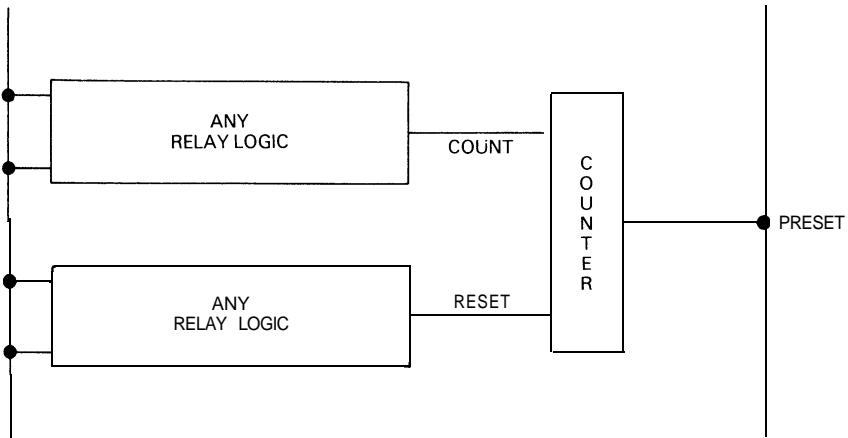
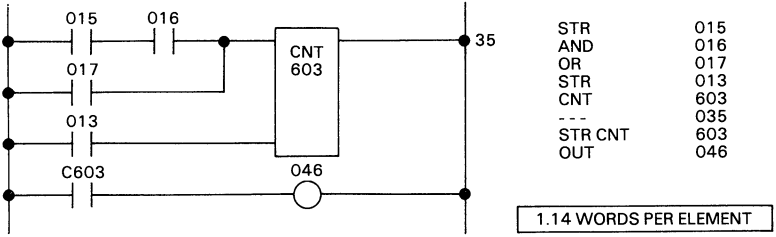

Figure 5.14 COUNTER LOGIC REQUIREMENTS

Figure 5.15 illustrates the operation of counters. As with the timer logic, the relay logic driving the counters is built as separate rungs using normal relay programming techniques. Counter 603 will count (increment) whenever references 015 and 016 are both ON or reference 017 is ON. If one parallel path is energized while the other is also ON, no additional count is recorded. When the count reaches 35, its preset value, coil 603 is energized, contact C603 closes, and coil 46 is energized. Counting will continue beyond the preset value, and will continue until the counter is reset. Whenever reference 013 is energized, regardless of the count or top rung status or coil state, counter 603 will be reset to zero and held at that value until reference 013 is de-energized.



KEY	ON LED'S	DISPLAY	KEY	ON LED'S	DISPLAY	KEY	ON LED'S	DISPLAY
STR	STR		STR	STR		STR	STR	
SHF	STR, SHF		SHF	STR, SHF		CNT	STR, CNT	
1	STR, SHF	1	1	STR, SHF	1	SHF	STR, CNT, SHF	
5	STR, SHF	15	3	STR, SHF	13	6	STR, CNT, SHF	6
ENT	ADR	0.0.0.1	ENT	ADR	0.0.0.4	0	STR, CNT, SHF	60
AND	AND		CNT	CNT		3	STR, CNT, SHF	603
SHF	AND, SHF		SHF	CNT, SHF		ENT	ADR	0.0.0.7
1	AND, SHF	1	6	CNT, SHF	6	OUT	OUT	
6	AND, SHF	16	0	CNT, SHF	60	SHF	OUT, SHF	
ENT	ADR	0.0.0.2	3	CNT, SHF	603	4	OUT, SHF	4
OR	OR		ENT	ADR	0.0.0.5	6	OUT, SHF	46
SHF	OR, SHF		SHF	SHF		ENT	ADR	0.0.0.8
1	OR, SHF	1	3	SHF	3			
7	OR, SHF	17	5	SHF	35			
ENT	ADR	0.0.0.3	ENT	ADR	0.0.0.6			

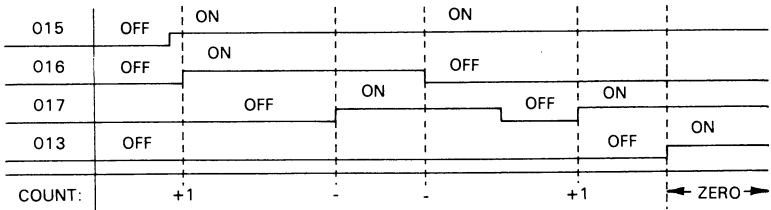

Figure 5.15 COUNTER EXAMPLE

EXTENDING THE TIMER AND COUNTER RANGE

Timers and counters can be connected in series or cascaded to extend their range beyond four digits. Figure 5.16 illustrates several techniques to extend preset ranges by using multiple timer and counter functions. Timer 611 will record time when references 206 and 225 are energized. After 800 seconds have elapsed, it energizes its coil and stops recording time. However, timer 612 starts as soon as 611 reaches its preset and continues for another 950 seconds. This is a total of 1750 seconds from the time T611 started. Whenever references 206 or 225 are de-energized, timer 611 is reset to zero, de-energizing coil 611, and also resetting timer 612 (if necessary).

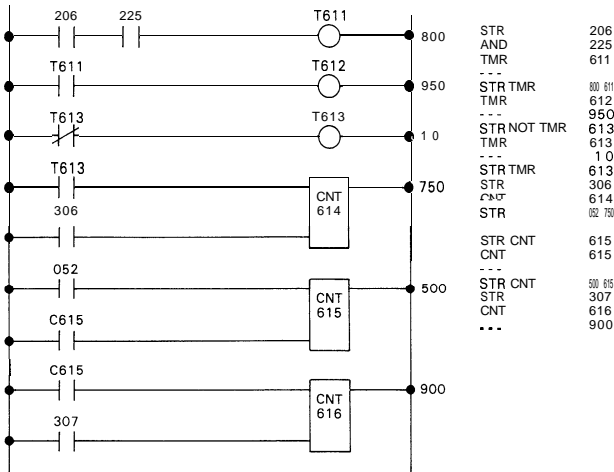

Figure 5.16 EXAMPLE OF EXTENDED TIMERS AND COUNTERS

Another pair of functions are timer 613 and counter 614. Timer 613 is a self resetting timer with a preset of one second (10 tenths). It produces outputs, each one scan long, every second from the time the CPU starts until it is turned OFF. Counter 614 counts up to 750 of these pulses (750 seconds), until reset by reference 306. Since counters are retentive, using timer 613 to produce a one second clock that is counted by 614, results in a retentive timer. A similar result occurs if the top rung of counter 614 were referenced to internal coil 375 (0.1 sec clock) rather than 613. The third example in Figure 5.16 consists of counters 615 and 616. Counter 615 counts reference 52, up to 500, and then resets itself. Counter 616 records how many of these groups of 500 counts occur. Since counter 616 has a preset of 900, its coil will be energized after 450,000 transitions of reference 52 have occurred. At anytime, counter 615 has a representation of the small number of counts, 0-499 or least significant portion, and counter 616 the larger values representing multiples of 500 (500 to 450,XXX), or most significant portion.

HIGH SPEED COUNTER

The built-in high speed counter can count incremental (up) pulses at the rate of 2000 per second (2 kHz) up to a preset value of 9999. Up to 20 preset points can be programmed, which allows the Series One Junior PC to control up to 20 high speed counting or sequencing events. On the input (top) terminal strip are two terminals for connection of field devices to the high speed counter. Circuit 15 is the count (CNT) input and circuit 16 is the reset (RST) input. The counter can be reset from an external source or through user programming with the RST (reset) function

COUNT ENABLE INPUT

When programming a high speed counter, the first line of permissive logic is NOT the count input, it is a COUNT ENABLE input. The counter is incremented automatically by the device wired to circuit 15 (CNT) on the PC, when the enable contact is closed. CNT input, (circuit 15) on the PC should NOT be programmed as the count enable input. If circuit 15 were used as the count enable input, erratic and unpredictable counting will occur. Optionally, a closed contact, referencing coil 374 can be programmed as the count enable input. This will enable the counter after the first logic sweep.

RESET INPUT

The second line of permissive logic is a reset input programmed by the user. The hardware input (circuit 16, RST) on the PC, will also reset the counter. If it is desired to reset the counter from hardware input 16, then the reset contact in the program should be programmed as a normally open contact, referencing 374. This will ensure that the counter is reset until after the first logic sweep has had time to initialize the rest of the program.

HIGH SPEED COUNTER REFERENCE

Reference 624 is assigned to the high speed counter. This must be referenced as CNT 624 in the user program in order to define the high speed counter. When programming a high speed counter control sequence, the outputs to be controlled by the counter must be programmed before the high speed counter. When programming a rung of logic to be controlled by the high speed counter, first enter a contact using the high speed counter reference 624. Next enter the preset value and finally the output to be controlled.

PROGRAMMING THE HIGH SPEED COUNTER

To help clarify the high speed counter operation, refer to the programming example and timing chart in Figures 5.17 and 5.18 as an aid to the following discussion. The memory address (in decimal) of the first element of each rung is shown to the left of the rung. Each program entry uses one word of memory. For example, the second rung contains three entries; STR 624, 1000, and SET 20. This rung uses three words of memory. Memory addresses are referenced for further clarity in the discussion.

HIGH SPEED COUNTER OPERATION

When entering a high speed counter program, the rungs of logic for the program should be entered immediately after the first rung of logic in the user program. The first rung of the high speed counter program, through the end of the rung containing the high speed counter definition, constitutes the complete high speed counter program.

When programming the high speed counter logic, a preset value must be entered each time the counter is referenced as an open or closed contact (see memory address 0001). In other words, each time the high speed counter reference 624, is programmed, a preset value (memory address 0002) must be entered.

After the complete user program has been entered and the RUN mode has been selected, the CPU performs certain internal functions as a part of its operating system. Before going to the RUN mode, the CPU searches the user logic for high speed counter presets. Any presets found are stored in a table, located in the CPU's memory, in ascending order for later use. Then the CPU goes to the RUN mode and begins program execution.

As each rung of user logic is executed, beginning at memory address 0000, the CPU checks the current value of the high speed counter, which is being incremented and stored in an area of CPU memory. If this current value is equal to any of the values in the table, for example, scan at memory address 0039 and accumulated count value at 3000, the user logic program is interrupted at that point and program execution immediately returns to the beginning of the program (memory address 0000) and proceeds from that point. This is why the high speed counter program must be entered at the beginning of your program. This way it will be executed faster than if it were located later in the program.

Each rung of the program will be executed in order, until the scan reaches the high speed counter definition. The output table in the CPU is updated immediately as each rung before the high speed counter is executed. When the high speed counter definition is reached (memory address 0021), any outputs that are conditioned to be turned on, will now turn on. For example, if the preset value that caused the interrupt process to begin is 3000, then output 22 would turn on at this point. This interrupt process allows the logic in the high speed counter program to be executed faster than if it had to wait for the normal scan sequence to reach it.

When program execution reaches the high speed counter definition, program execution will resume at the point in the user logic (memory address 0039) where it was originally interrupted. The maximum number of preset points is 20. If an attempt is made to program more than 20 preset points, an error code EI3 is displayed on the programmer as a visual indication that the maximum number has been reached.

RECOMMENDATIONS FOR PROGRAMMING PRESET VALUES

In order to fully realize the maximum frequency of 2000 pulses per second (2kHz), the following recommendations should be followed when programming preset values for the high speed counter. **If these recommendations are not followed, the maximum attainable frequency of the high speed counter will be considerably less (in the range of 300 to 800 Hz) than 2 kHz.**

1. **Do not use the values 0 or 1 as presets.** If a zero or common starting point is required for your application, use the upper limit of your preset values as that point.

For example: with presets of 100, 200, 300, 400, and 500, the preset 500 can be considered the same as a zero starting point.

100 200 300 400 500 100 200 300, etc.
(or zero)

2. **Do not use adjacent preset values (e.g. 5, 6, 7, etc.).** Use of adjacent preset values will considerably limit the maximum rate at which the high speed counter can operate.
3. It is recommended that preset values be staggered; for example, 5, 10, 15, or 100, 200, 300, etc. If preset values are programmed using these recommendations, the full 2 kHz pulse rate of the high speed counter is available.

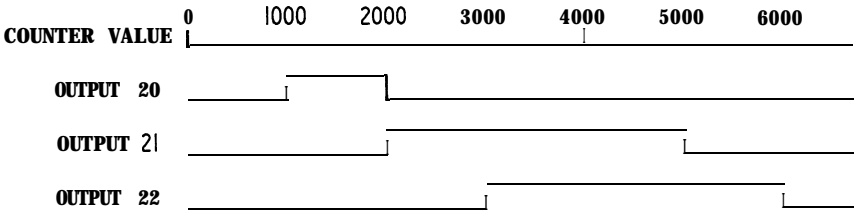

Figure 5.17 HIGH SPEED COUNTER TIMING CHART

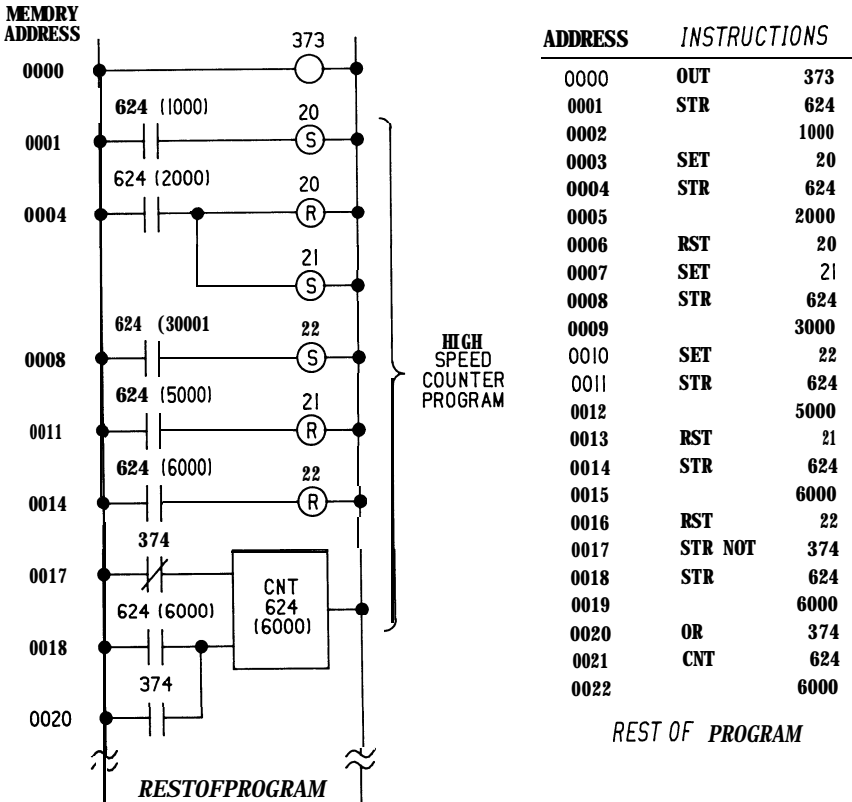

Figure 5.18 HIGH SPEED COUNTER PROGRAM EXAMPLE

SEQUENCERS

All Series One Junior counters have another very powerful feature. They can be programmed to function as sequencers. Each counter can control a 1000 step sequencer. Any Series One Junior PC can have up to twenty 1000 step sequencers, each similar to a stepping switch or drum sequencer. Figure 5.19 illustrates the operation of one of these sequencers. Each sequencer moves from one position to the next as directed by some user defined signal, shown here as a pushbutton. Counters are incremented once each time a count is recorded. Each sequencer starts at zero or home position when the counter is reset, and progresses through its steps one at a time in numerical order. At any time the position of the sequencer can be determined by the current count value contained in its storage. Although any sequencer can have up to 1000 steps, many applications are solved with a smaller number. To limit a sequencer to less than 1000 steps, the preset on the counter is used. As with any counter, timer, or other coil, each step of the sequencer can control any number of contacts.

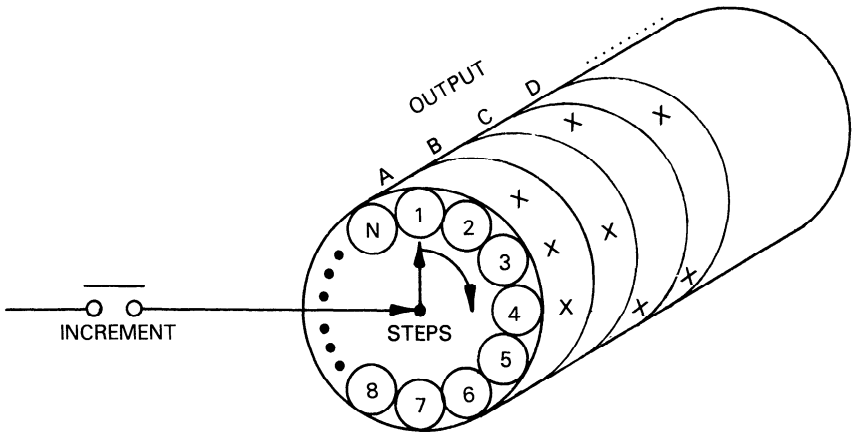

Figure 5.19 ILLUSTRATION OF SEQUENCER OPERATION

To illustrate the capabilities of the sequencer, refer to the sample problem in Figure 5.20. The sequence map in this example is in the form of a timing diagram that has an overall cycle of 45 seconds. This time is subdivided into increments of 5 seconds to satisfy the requirements of this application. There are six outputs to be controlled during the sequence with the desired ON periods shown by the horizontal lines. Outputs are assigned and step numbers (starting at zero) are entered for each time period.

To drive the sequencer (Figure 5.21), a timer (600) is entered to reset itself every 5 seconds. Input 030 is used to control the sequencer, which will not be incremented except when this input is energized. When energized, timer 600 will produce one pulse every 5 seconds. Counter 601 increments its count once each pulse, stepping the sequencer. Input 031 will reset the sequencer to home (zero) whenever it is energized, regardless of the count or position of the sequencer. The counter will count up to eight and then stop waiting for a reset signal.

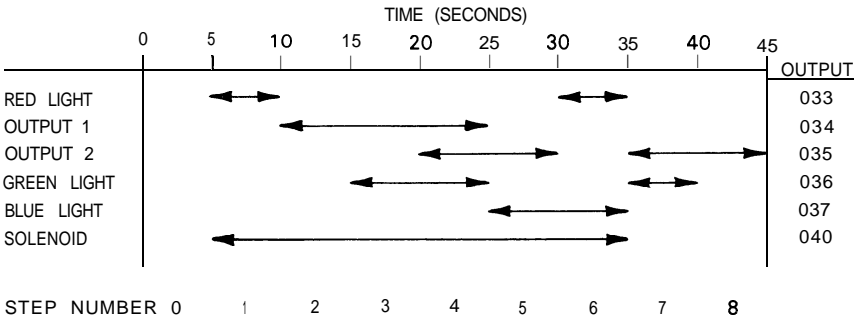

Figure 5.20 SEQUENCER EXAMPLE

The outputs from the sequencer are programmed using relay logic. The first reference is to the counter (6XX) controlling the sequencer and then to the current value that is going to control that contact. For example, if a reference to counter 601 is desired that will pass power only when that counter has a current count of 1, the value 1 is entered after the normally open contact reference 601.

In this example, output 033 (red light) will be energized during 5 second intervals each for steps 0, 1, and 6. Similarly, output 034 (Output 1) will be energized at step 2, sealed and held until the beginning of step 5 (end of step 4). The other outputs are controlled using similar logic with parallel contacts or seal circuits. If an output is ON for more steps than it is OFF, normally closed contacts would probably simplify your logic.

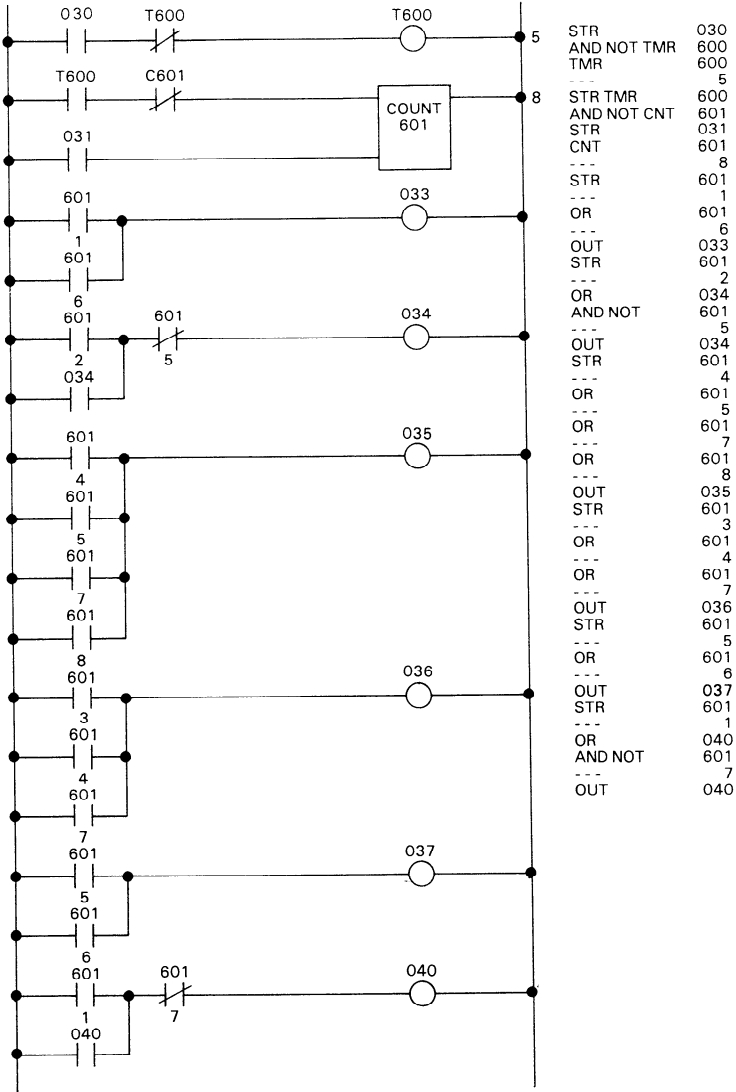

Figure 5.21 EXAMPLE OF SEQUENCER LOGIC

SHIFT REGISTERS

Another powerful feature of all Series One Junior PCs is the ability to simulate the operation of shift registers. There are many physical devices that operate similar to shift registers such as an anchor chain, a conveyor belt, an indexing machine, a line of customers at a refund desk, etc. As in these examples, there are several common features that can be used to describe the general features of a shift register. There is movement in all examples, normally in one direction. This movement can be defined as a group of fixed increments such as one link, one box position, one operation, or one person. The order of activities (pulling chain in, placing boxes on conveyor, loading parts to be worked on or tested, or adding people to the line) normally remains the same, first in, first out. In case of power failure in the plant or building, it is desirable that the shift register retain its content (part position, people order, boxes on conveyor, etc). However, in many cases it is also desirable that under logic control, the shift register be cleared, such as for start up on Monday morning. It is much easier for the user to clear a retentive shift register than it is to restore a cleared (volatile) content.

A shift register is a group of storage locations synchronized by a timing or clock signal. Figure 5.22 illustrates the operation of a typical shift register with six stages.

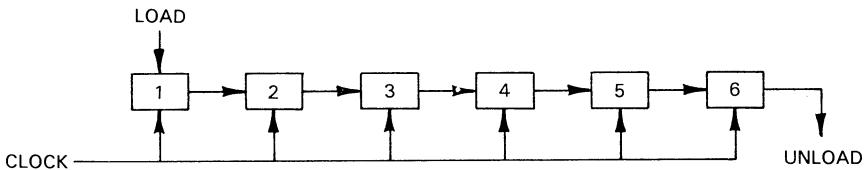

Figure 5.22 TYPICAL SHIFT REGISTER

Each stage can store a single bit which can represent a good or bad part, part or no part, ON or OFF, a one or zero, etc. Data is loaded into the first stage, incremented through the shift register one position per clock pulse, and then out the other end. When the clock signal goes from OFF to ON, each stage shifts one position towards the right. The content of stage 6 is unloaded, stage 5 content moves into stage 6, stage 4 into 5, etc. until stage 1 moves into stage 2. Stage 1 is then cleared, awaiting a load signal from other logic.

Within the Series One Junior, there are 155 storage locations for use with shift registers. Locations 140-277 are non-retentive and locations 300-372 can be made retentive by programming coil 373 into memory location 0000. Since the Series One Junior logic functions are easy to use, yet provide the user with unmatched flexibility, they allow many separate shift registers to be built of various lengths as long as the total quantity of stages does not exceed 155.

Each shift register requires several pieces of information to perform its function. Since it is a serial operation, there must be a definite beginning and ending. At the beginning, parts are put into the machine or boxes are put on the conveyor, thus a signal is required to indicate when a part is to be placed into the shift register at stage one. Similarly, there is a signal that indicates when the shift register should increment or move one position. The third and last signal is one to indicate when the shift register (all stages) should be cleared to zero or OFF conditions.

SHIFT REGISTER REFERENCES

The definition of size for any shift register requires the user to define how many stages are desired, and which references are assigned to this function. The size of the shift register is usually established by the maximum size of the physical device it is controlling. For example, how many links are in the chain, how many boxes can be placed on the conveyor, how many positions has the index machine, or how many people is there space for?

References to stages of shift registers within the Series One Junior are 140 to 372. Each stage or position of any shift register should be unique. Do not share storage locations between different shift registers. However, multiple logic functions can be programmed to operate upon one shift register to produce bi-directional shift registers, ring counters, first in-first out or last in-first out stacks. Each shift register reference can control any number of relay contacts, both normally open and normally closed.

SHIFT REGISTER OPERATION

To illustrate the operation of serial shift registers, Figure 5.23 defines a theoretical problem using a sequential assembly machine. The machine has space for a maximum of 12 parts at any one time. These may be cups or other storage locations physically on the machine. The operations are performed while the machine is stationary and then all storage locations (cups) are indexed rapidly one position towards the right.

There are three separate operations such as part assembly, welding, clamping, nuts tightened, painting and label placement, etc. Since it would be a waste of material and machine time to operate on locations without a part in place, there is a sensor on the first location to detect when a part is present. To the right is a testing position to determine good parts and bad parts for later separation. Each position of the machine is assigned a number for later reference to the shift register. Notice that positions 3, 5, 7, 9, 10, and 12 are only holding locations to store parts in progress and are related to the mechanical layout of the machine.

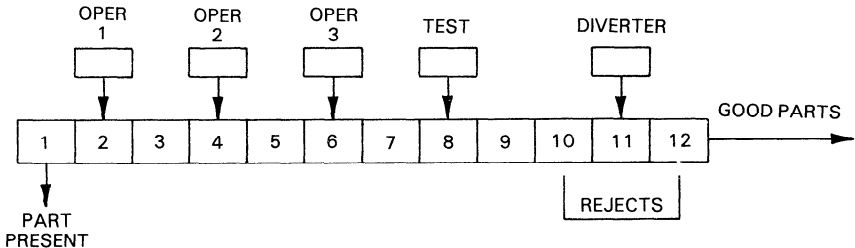

Figure 5.23 EXAMPLE OF A SHIFT REGISTER

Figure 5.24 illustrates the logic used to solve this problem. The following I/O references are assigned for use in this logic and can be changed as necessary to fit your application.

Part Present (Input)	045
Test OK (Input)	036
Reset All (Input)	047
Operation 1 (Output)	130
Operation 2 (Output)	131
Operation 3 (Output)	132
Test (Output)	133
Diverter (Output)	134
Shift Permissive (Internal)	214

The timing of each operation allows the machine to index one position every 3 seconds. Timer 601 produces an output every 3 seconds as long as the internal permissive is satisfied. This coil (214) is developed elsewhere and indicates all operations have been completed and hardware is out of the way, allowing movement without damaging the machinery. The shift register itself has three parallel rungs each of which can be any combination of series and parallel contacts. The first is the INPUT signal. Whenever this is supplying power flow the first stage of the shift register will turn ON and remains ON even if the input changes. The middle rung is the CLOCK signal controlling the shifting of all stages. When this signal goes from OFF (no power flow) to ON (power flow), all stages will shift one position. This shifting is completed before other logic is solved. The bottom rung is the RESET signal. Whenever this signal is supplying power flow, all stages of the shift register will be turned OFF (cleared).

The references used by this shift register, which define the number of stages, must be defined. The reference for the shift register itself is the location of the first stage and immediately following that is the reference for the last stage of that shift register. In the example, input 045 indicates a part present and thus loads the first stage (331) of the shift register.

Timer 601 (3 seconds) and coil 214 (shift permissive) are both required before the shift occurs. Finally, input 047 is used to clear all shift register stages perhaps at the start of machine operation or otherwise under operator control. The shift register is built using references 331 through 344 (total 12 stages). The remaining relay logic merely connects the individual stages of the shift register to their output in order to exercise proper control. The only exception is the next to the last rung. This rung receives the test signal and resets stage 340 if the test is passed. Thus when the later stage (343) receives the data, it will not activate coil 134 to operate the diverter. Because of this, good parts are passed and the diverter operates only for bad parts, not for empty locations or good parts.

Normally many parts will be processed through this machine, continuously flowing from input at position 1 to output from position 12. However, for the purpose of illustration, a single part will be examined as it moves down the machine. The part is placed in position 1, energizing input 045 and setting shift register stage 331. After three seconds, timer 601 energizes clocking the shift register causing the ON state for this part to move into stage 332. Timer 601 will reset itself and stage 331 is cleared. When stage 332 is energized, so is output 130 causing operation 1 to be performed on this part. An additional three seconds pass and another clock cycle causes the ON to move to stage 333. Stage 332 will be loaded from 331 which is OFF as long as additional parts are not processed. The above discussion assumes no delays are experienced with the permissive.

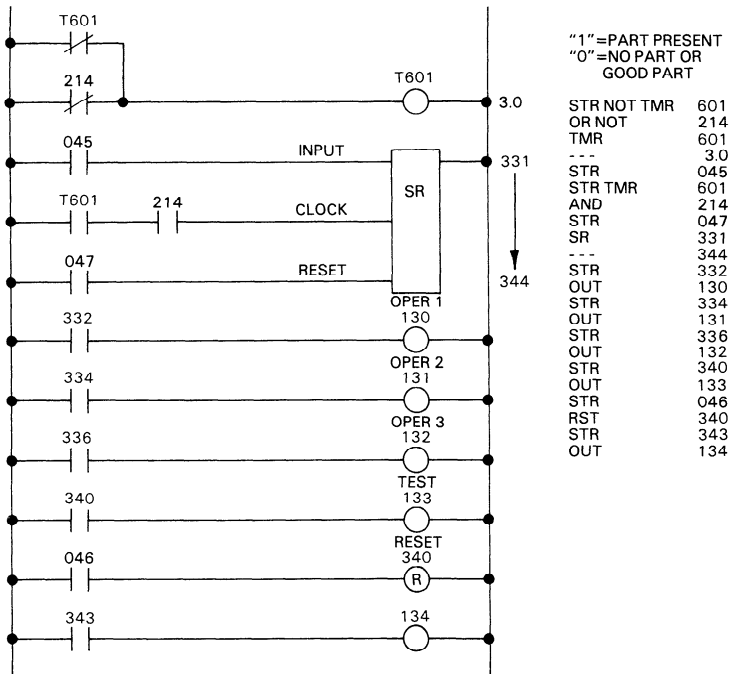

Figure 5.24 SAMPLE SHIFT REGISTER LOGIC

The above operation repeats itself as the part goes through stages 334 (operation 2), 335 (rest), 336 (operation 3), 337 (rest), and 340 (test) at three second intervals. While at the test position, output 133 is energized and the test OK input (046) is expected. If the part passes the test, input 046 will reset stage 340 making the remainder of the shift register act as if no part were present and allowing the part to pass straight on through. However, if the test is not passed, the ON stage moves to 341, 342, and 343 at three second intervals. At stage 343, it energizes output 134 causing the diverter to push the defective part into the reject bin.

Other logic can be added to improve the capabilities of this program. For example, a timer could measure the delay from the manual cycle (601 energized) and receipt of the permissive (214). It would also alarm if this delay was excessive, such as 5 or 8 seconds beyond the normal 3 seconds. Counters could also be installed to record both good and bad parts produced. This data can be read out and reset from the programmer whenever desired, such as each shift, day, week, etc.

FORCING I/O REFERENCES

An invaluable tool in the verification of user logic and field wiring is the ability to force I/O references. The operation of the I/O forcing operation is dependent on the I/O reference being forced. Inputs connected to external devices can be forced on or off for one solution of user logic. All other I/O references can be forced on or off indefinitely, but are overridden by user logic.

The most frequent user of the I/O forcing function is for verification of field wiring of outputs. Since user logic overrides the I/O forcing function it is recommended that this operation be performed with user program memory cleared. The key sequences for forcing I/O references are as follows:

- To force a specific I/O reference ON, enter the sequence:
SET, SHF, XXX (I/O reference), ENT
- To force a specific I/O reference OFF, enter the sequence:
RST, SHF, XXX (I/O reference), ENT

WARNING

WHEN FORCING INPUT POINTS WITH THE SET SEQUENCE, WHICH FORCES THE INPUT TO THE ON STATE, THE PHYSICAL STATE OF THE INPUT MAY BE OVERRIDDEN. IF THE FORCED SET OCCURS IN THE USER LOGIC PROGRAM BEFORE THE INPUT IS CHECKED IN THE SAME I/O SCAN, THE SET STATE WILL TAKE PRECEDENCE AND COULD CAUSE AN OUTPUT TO BE TURNED ON AT THE WRONG TIME.

CHAPTER 6 I/O CAPABILITIES

INTRODUCTION

Input and Output circuits for a Series One Junior PC system are built into each basic unit and on Series One I/O modules that are installed in the expansion rack. Each Series One Junior PC basic unit provides 15 input circuits and 9 output circuits. I/O Expansion units provide 16 input and 10 output circuits. Series One modules for the expansion rack are available that provide either 4, 8, or 16 inputs or outputs. A maximum of 72 I/O points can be contained in an expansion rack (10-slot), thus providing a total of 96 I/O points in a Series One Junior PC system.

This chapter is a guide to the capabilities and physical wiring of the Series One Junior basic units and Series One I/O modules. It provides the information required for wiring and applying the basic units and I/O modules.

I/O REFERENCE ASSIGNMENT

I/O references are fixed for each model of Series One Junior. I/O references for modules installed in an expansion rack, are assigned according to the slots into which they are installed, as shown in Chapter 2, Figure 2.5.

FIELD WIRING TO BASIC UNITS

There are 17 terminals on the top and bottom of the unit for field wiring connections. Each of the 2 terminal blocks is protected by a removable plastic cover. This cover snaps into place and is keyed for proper orientation on the terminal blocks. When looking at the ends of the terminal blocks, notice that one end has 2 notches, while the other end has 3 notches. The covers have 2 protrusions on one end and 3 on the other, these must be properly matched to the terminal blocks. The covers have removable paper inserts, which provide a convenient writing space for circuit annotation.

TOP TERMINALS

The top terminals, labeled 0 to 16, provide a total of 15 connections to input devices. The last two input terminals (15 and 16) can be used for the high speed counter incremental pulse input and the reset pulse input. If terminals 15 and 16 are not being used as high speed counter inputs, they can be used as dc sink inputs. The function of the remaining terminals depends on the model. On some models, the last two terminals on the right are a source of 24 V dc @ 100 mA, maximum, which can be used as a source of power for external user devices, such as sensors.

BOTTOM TERMINALS

The bottom terminals provide the connections to field devices to be controlled by the PC's output circuits. These terminals are labeled 17 through 27, which correspond to the 9 output circuits, and their commons, labeled C1, C2, and C3. The C terminal, immediately to the right of terminal 27, is for connecting the shielded wire when an expansion cable is connected to a Series One Junior. The 4 remaining terminals, labeled G (Ground), H (Hot), N (Neutral for 115 V ac), and N (Neutral for 230 V ac) are for connecting the input source of ac power. Units requiring an input power source of 24 V dc, are labeled accordingly.

WARNING

ENSURE THAT PROPER CONNECTIONS ARE MADE WHEN CONNECTING AN AC SOURCE OF POWER. IF 230 V AC IS APPLIED TO THE 115 V AC NEUTRAL TERMINAL, THE UNIT MAY BE DAMAGED. THE 230 V AC NEUTRAL TERMINAL HAS A PROTECTIVE TAG ON IT, WHICH SHOULD NOT BE REMOVED UNLESS A 230 V AC POWER SOURCE IS TO BE USED.

FIELD WIRING TO I/O MODULES

Each of the I/O modules (Figure 6.1), unless otherwise indicated, has a terminal block attached to it with 10 terminals arranged as shown in Figure 6.2. Each of these terminals are capable of accommodating one AWG No. 12 or two AWG No 14 stranded wires.

The following pages provide specifications, wiring diagrams, typical schematics, and sample reference numbers for each module type. The typical schematics are intended to provide details for interfacing and not for maintenance or repair of these modules. The sample reference numbers should be adjusted by the user to the actual slot in which the modules are installed. Each slot provides eight references. Those modules that incorporate less than eight circuits still consume 8 I/O references. References not used are available as internal references. A 16 circuit I/O module uses 2 groups of 8 I/O references and can only be placed in slot 1 of an expansion rack.

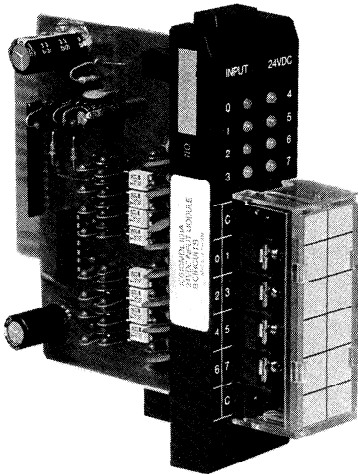

Figure 6.1
TYPICAL I/O MODULE

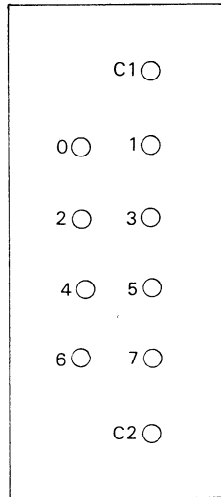
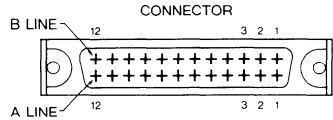

Figure 6.2
TYPICAL I/O MODULE
TERMINAL ARRANGEMENT

16 CIRCUIT I/O MODULES

Some 16 point I/O modules, which can only be installed in slot 1 of an expansion rack, are connected to user supplied input devices or user supplied loads through an I/O Interface cable which is 10 feet (3m) in length (Catalog Number IC610CBL105). One end of this cable has a 24-pin female connector which mates with a 24-pin male connector mounted on the faceplate of the I/O module. The wires on the opposite end of the cable are stripped and tinned for connection to user devices. Each of the wires is color coded for easy identification. Figure 6.3 is a wiring list for the I/O Interface cable. 16 point modules with screw terminals, have a removable socket type terminal block for user wiring. This terminal block is easily removed, which allows modules to be removed without disturbing the field wiring to the module. These high density modules are described at the end of this chapter.

GEJ-7000
Thumbwheel Interface Cable
Wire List and Installation Diagram



Pin No.	Signal	Wire color code
A1	674 Thumbwheel switch common	ORN (RED1)
A2	676 Thumbwheel switch common	GRA (RED1)
A3	units digit	1 WHT (RED1)
A4		4 YEL (RED1)
A5	tens digit	1 PNK (RED1)
A6		4 ORN (RED2)
A7	hundreds digit	1 GRA (RED2)
A8		4 WHT (RED2)
A9	thousands digit	1 YEL (RED2)
A10		4 PNK (RED2)
A11	not connected *	ORN (RED3)
A12	not connected *	GRA (RED3)

Pin No.	Signal	Wire color code
B1	675 Thumbwheel switch common	ORN (BLK1)
B2	677 Thumbwheel switch common	GRA (BLK1)
B3	units digit	2 WHT (BLK1)
B4		8 YEL (BLK1)
B5	tens digit	2 PNK (BLK1)
B6		8 ORN (BLK2)
B7	hundreds digit	2 GRA (BLK2)
B8		8 WHT (BLK2)
B9	thousands digit	2 YEL (BLK2)
B10		8 PNK (BLK2)
B11	not connected *	ORN (BLK3)
B12	not connected *	GRA (BLK3)

Color Code Example

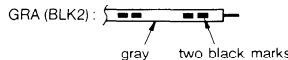
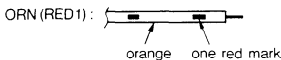

- ORN orange
- GRA gray
- WHT white
- YEL yellow
- PNK pink
- RED red
- BLK black

The white wire with three red marks and the white wire with three black marks are not used

* If solid state BCD input is used, connect to BCD input device common

Figure 6.3 I/O INTERFACE CABLE WIRING LIST

SERIES ONE JUNIOR CATALOG NUMBERS**Table 6.1 CATALOG NUMBERS**

DESCRIPTION	CATALOG NUMBER
Basic Units	
115 V ac IN, 115/230 V ac OUT	IC609SJR100
24 V dc Sink IN, 115/230 V ac OUT	IC609SJR102
24 V dc Sink IN, 24 V dc Sink OUT	IC609SJR110
24 V dc Sink IN, 24 V dc Sink OUT	IC609SJR114 *
24 V dc Sink IN, Relay OUT	IC609SJR120
24 V dc Sink IN, Relay OUT	IC609SJR124 *
24 V dc Source IN, Relay OUT	IC609SJR121
Expansion Units	
24 V dc Sink IN, 24 V dc Sink OUT	IC609EXP110
24 V dc Sink IN, Relay OUT	IC609EXP120
24 V dc Source IN, Relay OUT	IC609EXP121
UL Listed Units	
Basic Unit—115 V ac IN, 115 V ac OUT	IC609SJR101
Expansion Unit—115 V ac IN, 115 V ac OUT	IC609EXP101
I/O Modules —	
115 V ac Input, 8 Circuits	IC610MDL125
230 V ac Input, 8 Circuits	IC610MDL127
115 V ac Isolated Input, 4 Circuits	IC610MDL126
24 V dc Sink Input, 8 Circuits	IC610MDL101
24 V dc Sink Input, 16 Circuits	IC610MDL106
24 V dc Sink Load Input, 16 Circuits	IC610MDL107
24 V ac/dc Source Input, 8 Circuits	IC610MDL111
24 V ac/dc Source Input, 16 Circuits	IC610MDL112
115/230 V ac Output, 8 Circuits	IC610MDL175
115/230 V ac Isolated Output, 4 Circuits	IC610MDL176
24 V dc Sink Output, 8 Circuits	IC610MDL151
24 V dc Sink Output, 16 Circuits	IC610MDL156
24 V dc 2 Amp Sink Output, 4 Circuits	IC610MDL153
24 V dc 2 Amp Sink/Source Output, 4 Ckts.	IC610MDL154
24 V dc Source Output, 8 Circuits	IC610MDL155
24 V dc Sink Output, 16 Circuits	IC610MDL157
24 V dc Source Output, 16 Circuits	IC610MDL158
Relay Output, 8 Circuits	IC610MDL180
Relay Output, 16 Circuits	IC610MDL182
I/O Modules, UL Listed	
115 V ac Input, 6 Circuits	IC610MDL135
Relay Output, 5 Circuits	IC610MDL181
115 V ac Output, 6 Circuits	IC610MDL185
I/O Modules — Special	
24 V dc Input/Output, 4 In/4 Out	IC610MDL103
24 V dc Sink Input/Relay Output, 4 In/4 Out	IC610MDL104
Fast Response I/O, 4 In/2 Out	IC610MDL115
I/O Simulator, 8 Input Circuits	IC610MDL124

**115 V ac INPUT/ 115/230 V ac OUTPUT
IC609SJR100**

This basic unit provides 13 ac and 2 dc input circuits and nine ac output circuits. The 15 input circuits are each designed to receive a single discrete (ON/OFF) signal from user supplied devices such as limit switches, pushbuttons, selector switches, and relay contacts. Circuits 15 and 16 can be used for high speed count input and reset or used as normal dc sink input points. The 9 ac output circuits are each capable of controlling user supplied discrete (ON/OFF) loads. Typical loads include relay coils, motor starters, solenoid valves, and indicator lights. The ac output circuits were designed to be used for 115 or 230 V ac loads. The ON/OFF state of each input and output circuit is indicated by an LED. Figures 6.4 and 6.5 provide wiring information for this unit. Following are specifications for each of the input and output circuits.

AC INPUT CIRCUITS (0-14)

Input Points	13
Operating Voltage	97-132 V ac
AC Frequency	47-63 Hz
Input Current (nominal)	10 mA
Input Impedance	11 K ohms
ON Level	Above 80 V ac
OFF Level	Below 20 V ac
OFF to ON Response	10-30 ms
ON to OFF Response	10-30 ms
Circuit Indicator	Logic Side

DC (HIGH SPEED COUNTER) INPUT CIRCUITS (15, 16)

Input Points	2
Input Device	Input 15 must use an open collector device
Maximum Voltage on Input Terminal (no load)	26 V dc
Open Circuit Voltage of Input (nominal)	24 V dc
Input Current	12 mA
Input Impedance	1.8 K ohms
ON Level	0-7 V dc
OFF Level	18-26 V dc
OFF to ON Response	.1 ms
ON to OFF Response	.1 ms
Circuit Indicator	Logic Side
Maximum OFF Leakage	3 mA
Minimum ON Current	6 mA

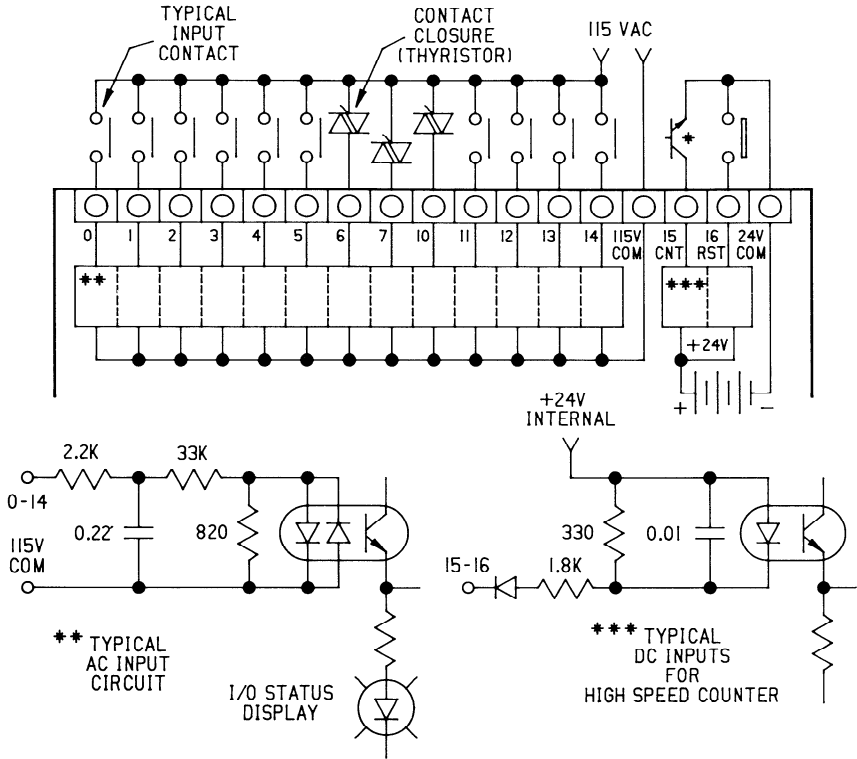

NOTE

* Input 15 must be driven by an open collector device when being used as a high speed counter input. If a normal switch contact were used, switch bounce could cause multiple incorrect input pulses to be counted.

Counter input circuits are dc inputs. Terminals No. 15 and 16 can be used as normal dc sink inputs when not being used as high speed counter inputs.

Figure 6.4 WIRING FOR 115 V ac INPUTS, BASIC UNIT

AC OUTPUT CIRCUITS

Output Points	9
Operating Voltage	97-265 V ac
AC Frequency	47-63 Hz
Maximum Current	1 A Continuous
Maximum Inrush	10 amps for 10 ms 8 amps for 16 ms 5 amps for 42 ms 3.8 amps for 100 ms
Max. Leakage Current	7.0 mA @ 220 V, 60 Hz 3.5 mA @ 110 V, 60 Hz
ON Voltage Drop	1.6 V @ 1 amp 1.6 V @ 0.5 amp
Smallest Recommended Load	25 mA
OFF to ON Response	1 ms
ON to Off Response	8-10 ms (1/2 cycle)
Circuit Indicator	Logic Side
Fuses (Internal, soldered)	2A, 1 for each circuit

BLEEDER RESISTOR CALCULATION

The following information is an aid for calculation of the resistance and power rating for the bleeder resistor described in the NOTE included with the output wiring circuits for each basic unit.

To find maximum resistor value

$R = V1 \times 500$, V1 is the minimum voltage that will normally turn on the load.

To find minimum power rating of the resistor

$$Pr = \frac{V2 \times V2 \times 2}{R}$$

V2 is the voltage that is normally applied to turn on the load and R is the value calculated above.

For resistor values, use a resistor with the closest standard lower value. For power rating, use a resistor rated at the closest higher standard wattage rating.

Example 1:

A neon light has a turn-on voltage of 20 V, but has 115 V normally applied to turn it on.

$R = 20 \times 500 = 10,000$ ohms, use 10,000 ohms, (this is a standard value).

$$Pr = \frac{115 \times 115 \times 2}{10,000} = 2.6$$

watts, use 3 watts, since this is the next higher standard wattage value.

Example 2:

A 24 V relay coil with a nominal turn-on voltage of 18 V.

$R = 18 \times 500 = 9,000$ ohms, use 8.2 K ohms as closest available lower standard value.

$$Pr = \frac{24 \times 24 \times 2}{8200} = .14$$

watts, minimum, use 1/4 watt resistor as closest higher standard value.

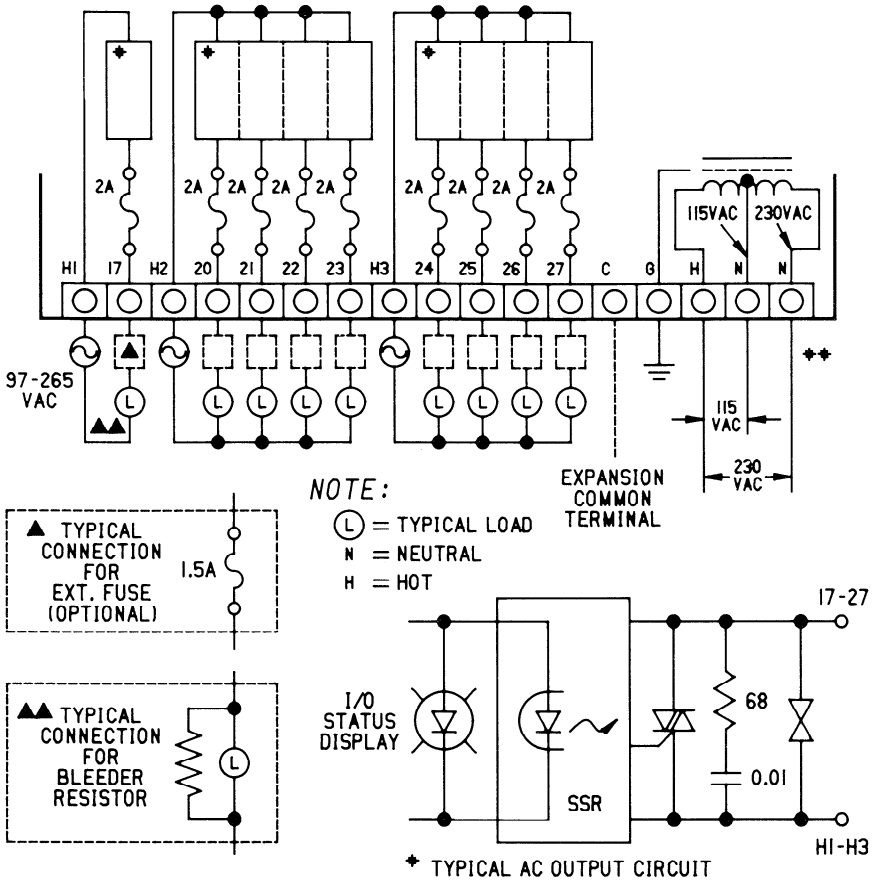

CAUTION

** **DO NOT CONNECT THIS TERMINAL (230 V AC N) UNLESS USING 230 V AC, OTHERWISE DAMAGE TO THE UNIT MAY RESULT.**

NOTE

Since a surge-absorbing circuit is built-in, there is current leakage through the circuit. A bleeder resistor should be attached to prevent incorrect operation in the event that light loads, such as small relays or neon lamps, are used. Leakage may turn on these devices if a bleeder resistor is not used.

Figure 6.5 WIRING FOR 115 V ac OUTPUTS, BASIC UNIT

**24 V dc SINK INPUT — 115/230 V ac OUTPUT
IC609SJR102**

This basic unit provides 15 dc input circuits and 9 ac output circuits. The 15 input circuits are each designed to receive a single discrete (ON/OFF) signal from user supplied devices such as limit switches, pushbuttons, selector switches, and relay contacts. Circuits 15 and 16 can be used for high speed count input and reset or used as normal dc sink input points. The 9 ac output circuits are each capable of controlling user supplied discrete (ON/OFF) loads. Typical loads include relay coils, motor starters, solenoid valves, and indicator lights. The ON/OFF state of each input and output circuit is indicated by an LED. Figures 6.5a and 6.5b provide wiring information for this unit. Following are specifications for each of the input and output circuits.

DC INPUT CIRCUITS (0-14)

Input Points	15
Maximum Voltage on Input Terminal (no load)	26 V dc
Open Circuit Voltage Of Input (nominal)	24 V dc
Input Current	12 mA
Input Impedance	1.8 K ohms
ON Level	0-7 V dc
OFF Level	18-26 V dc
OFF to ON Response	5-10 ms
ON to OFF Response	5-10 ms
Circuit Indicator	Logic Side
Maximum OFF Leakage	3 mA
Minimum ON Current	5 mA

DC (HIGH SPEED COUNTER) INPUT CIRCUITS (15, 16)

Input Points	2
Input Device	Input 15 must use an open collector device
Maximum Voltage on Input Terminal (no load)	26 V dc
Open Circuit Voltage of Input (nominal)	24 V dc
Input Current	12 mA
Input Impedance	1.8 K ohms
ON Level	0-7 V dc
OFF Level	18-26 V dc
OFF to ON Response	.1 ms
ON to OFF Response	.1 ms
Circuit Indicator	Logic Side
Maximum OFF Leakage	3 mA
Minimum ON Current	5 mA

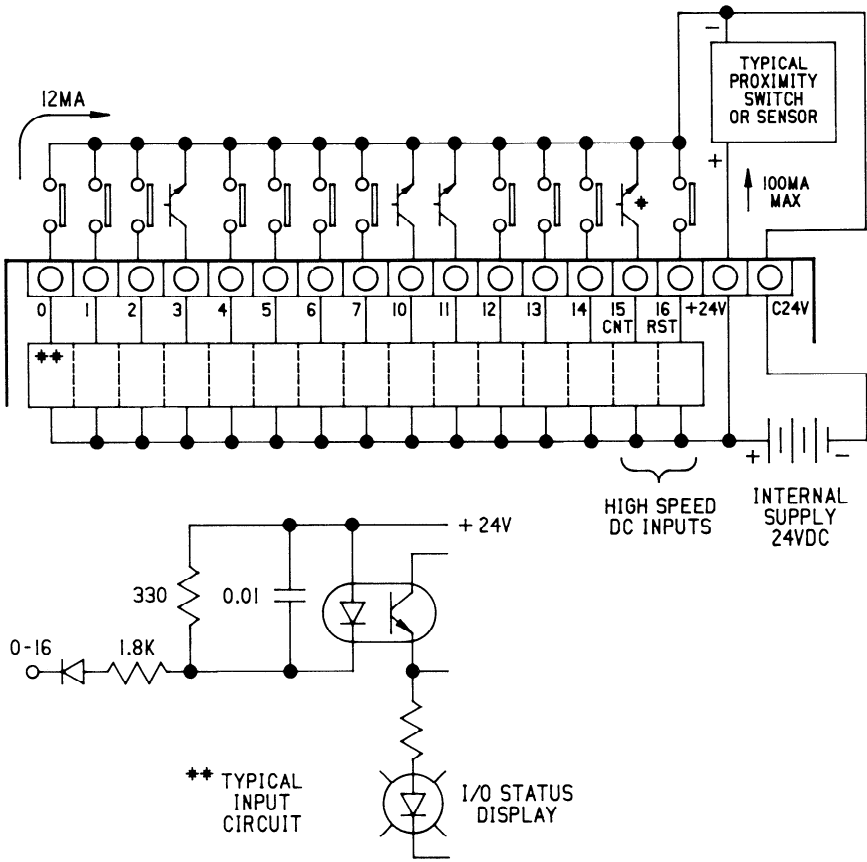

NOTE

* Input 15 must be driven by an open collector device when being used as a high speed counter input. If a normal switch contact were used, switch bounce could cause multiple incorrect input pulses to be counted.

Counter input circuits are dc inputs. Terminals No. 15 and 16 can be used as normal dc sink inputs when not being used as high speed counter inputs.

Figure 6.5a WIRING FOR 24 V dc SINK INPUTS, IC609SJR102

AC OUTPUT CIRCUITS

Output Points	9
Operating Voltage	97-265 V ac
AC Frequency	47-63 Hz
Maximum Current	1 A Continuous
Maximum Inrush*	10 amps for 10 ms
*(Use interposing relay if load inrush current exceeds specification)	8 amps for 16 ms 5 amps for 42 ms 3.8 amps for 100 ms
Max. Leakage Current	7.0 mA @ 220 V, 60 Hz 3.5 mA @ 110 V, 60 Hz
ON Voltage Drop	1.6 V @ 1 amp 1.6 V @ 0.5 amp
Smallest Recommended Load	25 mA
OFF to ON Response	1 ms
ON to OFF Response	8-10 ms (1/2 cycle)
Circuit Indicator	Logic Side
Fuses (Internal, soldered)	2A, 1 for each circuit

NOTE

Maximum current available from 24 V dc internal supply for customer use is 100 mA.

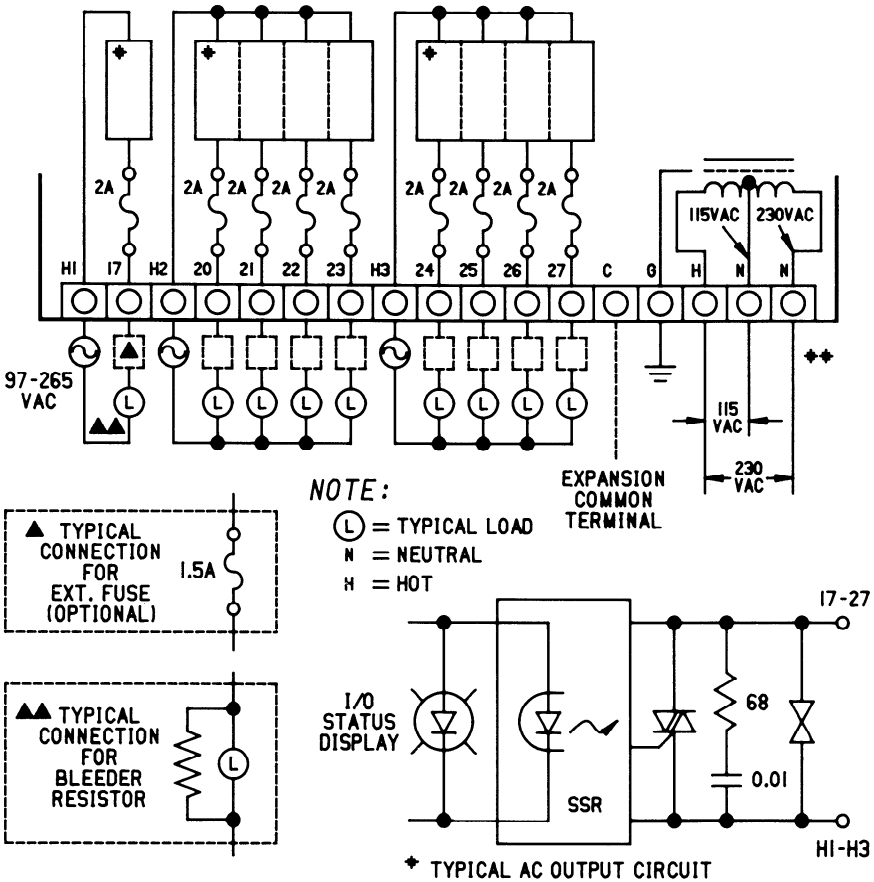

CAUTION

** **DO NOT CONNECT THIS TERMINAL (230 V AC NEUTRAL) UNLESS USING A 230 V AC POWER SOURCE, OTHERWISE DAMAGE TO THE UNIT MAY RESULT.**

NOTE

Since a surge-absorbing circuit is built-in, there is current leakage through the circuit. A bleeder resistor should be connected across the load to prevent incorrect operation in the event that light loads, such as small relays or neon lamps, are used. Leakage may hold these devices on if a bleeder resistor is not used.

Figure 6.5b WIRING FOR 115 V ac OUTPUTS, IC609SJR102

24 V dc SINK INPUT/24 V dc SINK OUTPUT
IC609SJR110
IC609SJR114

These 2 basic units provide 15 dc sink input circuits and 9 dc sink output circuits. The 15 input circuits are each designed to receive a single discrete (ON/OFF) signal from user supplied devices such as limit switches, pushbuttons, selector switches, and relay contacts. Circuits 15 and 16 can be used for high speed count input and reset or used as normal dc sink input points. The 9 dc sink output circuits are each capable of controlling user supplied discrete (ON/OFF) loads. Typical loads include relay coils, motor starters, solenoid valves, and indicator lights. The ON/OFF state of each input and output circuit is indicated by an LED. Figures 6-6 and 6-7 provide wiring information for this unit. Following are specifications for each of the input and output circuits.

The difference between the 2 units is that IC609SJR110 requires an operating power source of 115/230 V ac, while IC609SJR114 requires an operating power source of 24 V dc.

DC INPUT CIRCUITS (0-14)

Input Points	15
Maximum Voltage on Input Terminal (no load)	26 V dc
Open Circuit Voltage Of Input (nominal)	24 V dc
Input Current	12 mA
Input Impedance	1.8 K ohms
ON Level	0-7 V dc
OFF Level	18-26 V dc
OFF to ON Response	5-10 ms
ON to OFF Response	5-10 ms
Circuit Indicator	Logic Side
Maximum OFF Leakage	3 mA
Minimum ON Current	6 mA

DC (HIGH SPEED COUNTER) INPUT CIRCUITS (15, 16)

Input Points	2
Input Device	Input 15 must use an open collector device
Maximum Voltage on Input Terminal (no load)	26 V dc
Open Circuit Voltage of Input (nominal)	24 V dc
Input Current	12 mA
Input Impedance	1.8 K ohms
ON Level	0-7 V dc
OFF Level	18-26 V dc
OFF to ON Response	.1 ms
ON to OFF Response	.1 ms
Circuit Indicator	Logic Side
Maximum OFF Leakage	3 mA
Minimum ON Current	6 mA

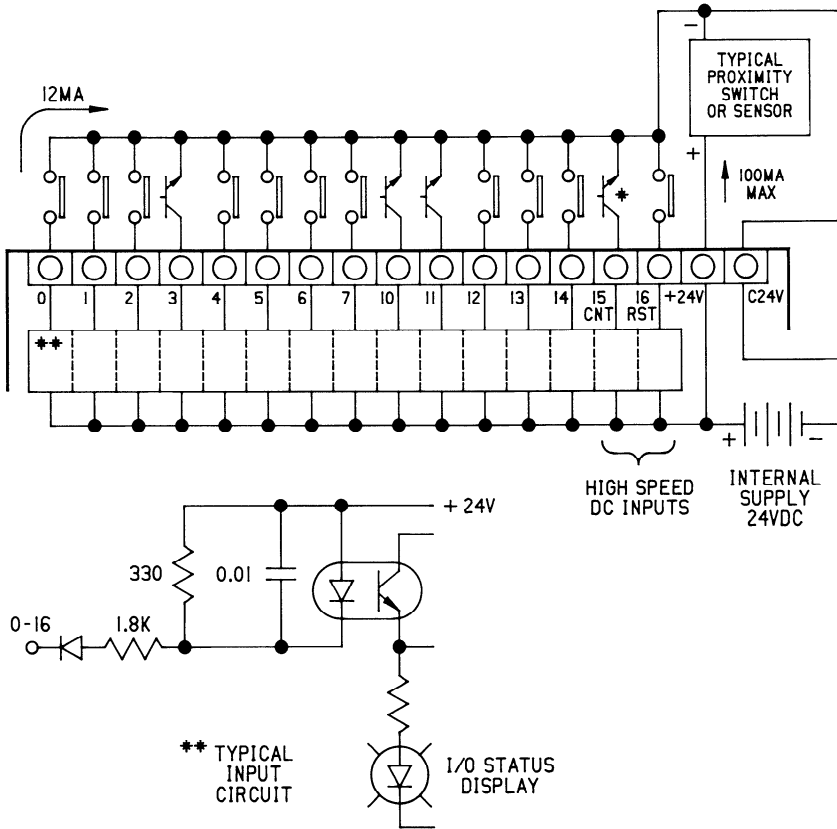

NOTE

* Input 15 must be driven by an open collector device when being used as a high speed counter input. If a normal switch contact were used, switch bounce could cause multiple incorrect input pulses to be counted.

Counter input circuits are dc inputs. Terminals No. 15 and 16 can be used as normal dc sink inputs when not being used as high speed counter inputs.

Figure 6-6
WIRING FOR 24 V dc SINK INPUTS, BASIC UNIT

Since current flows from the load into the field terminal for each circuit when the output is energized, these circuits are referred to as sink dc outputs. Specifications for the 9 output circuits are given below. The outputs are arranged in 3 groups of 1, 4, and 4. Each group can be powered from the same power source or they can be powered from separate power sources. The current rating for outputs 17-23 is different than the current rating for outputs 24-27.

24 V dc SINK OUTPUT CIRCUITS

Output Points	9
Operating Voltage	5-24 V dc
Peak Voltage	45 V dc
Maximum Current	1.0 amp, Outputs 17-23 0.5 amp, Outputs 24-27
Maximum Leakage Current	0.1 mA
On Voltage Drop, Maximum	0.9 V dc @ 1.0 amp 1.5 V dc @ 0.5 amp
Maximum Inrush	4 amps for 10 ms, Outputs 17-23 1 amp for 100 ms, Outputs 24-27
OFF to ON Response	0.1 ms
ON to OFF Response	0.1 ms
Circuit Indicator	Logic Side
Fuses (Internal, Fuse clips)	2 A (C1), 5A (C2, C3)

NOTE

It is recommended that a 2 amp fuse be placed in series with each output terminal, in order to protect the user load connected to each terminal.

A typical connection for the bleeder resistor described in the note on the following page is shown below.

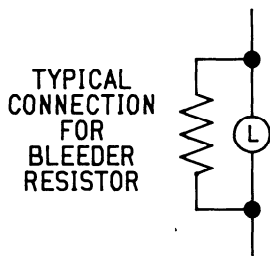

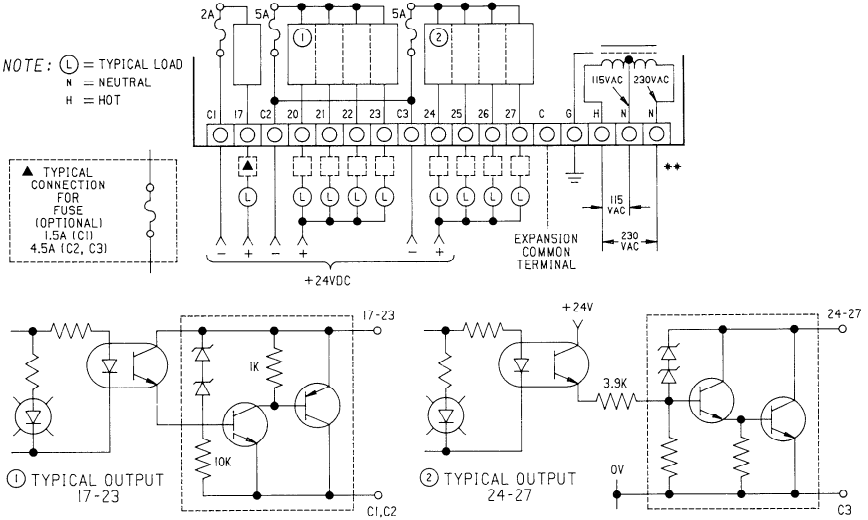

CAUTION

** Do NOT connect this terminal (230 V ac N) unless using 230 V ac. Otherwise damage to the unit may result.

NOTE

Since a surge-absorbing circuit is built-in, there is the chance of a small amount of current leakage through the circuit. A bleeder resistor should be attached to prevent incorrect operation in the event that light loads, such as small relays or LEDs are used. Leakage may turn these devices on if a bleeder is not used. Refer to Bleeder Resistor Calculation on page 6-7.

Figure 6-7
WIRING FOR 24 V dc SINK OUTPUTS, BASIC UNIT

24 V dc SINK INPUT/RELAY OUTPUT
IC609SJR120
IC609SJR124

These 2 basic units provide 15 dc sink input circuits and 9 relay output circuits. The 15 input circuits are each designed to receive a single discrete (ON/OFF) signal from user supplied devices such as limit switches, pushbuttons, selector switches, and relay contacts. Circuits 15 and 16 can be used for high speed count input and reset or used as normal dc sink input points. The 9 relay output circuits are each capable of controlling user supplied discrete (ON/OFF) loads. Typical loads include relay coils, motor starters, solenoid valves, and indicator lights. Since the relay output circuits were not designed for a specific voltage, such as 24 V dc or 115 V ac, they can be used for a wide variety of loads and signal types. The ON/OFF state of each input and output circuit is indicated by an LED. Figures 6.8 and 6.9 provide wiring information for this unit. Following are specifications for each of the input and output circuits.

The difference between the 2 units is that IC609SJR120 requires an operating power source of 115/230 V ac, while IC609SJR124 requires an operating power source of 24 V dc.

DC INPUT CIRCUITS (0-14)

Input Points	15
Maximum Voltage on Input Terminal (no load)	26 V dc
Open Circuit Voltage Of Input (nominal)	24 V dc
Input Current	12 mA
Input Impedance	1.8 K ohms
ON Level	0-7 V dc
OFF Level	18-26 V dc
OFF to ON Response	5-10 ms
ON to OFF Response	5-10 ms
Circuit Indicator	Logic Side
Maximum OFF Leakage	3 mA
Minimum ON Current	6 mA

DC (HIGH SPEED COUNTER) INPUT CIRCUITS (15, 16)

Input Points	2
Input Device	Input 15 must use an open collector device
Maximum Voltage on Input Terminal (no load)	26 V dc
Open Circuit Voltage of Input (nominal)	24 V dc
Input Current	12 mA
Input Impedance	1.8 K ohms
ON Level	0-7 V dc
OFF Level	18-26 V dc
OFF to ON Response	.1 ms
ON to OFF Response	.1 ms
Circuit Indicator	Logic Side
Maximum OFF Leakage	3 mA
Minimum ON Current	5 mA

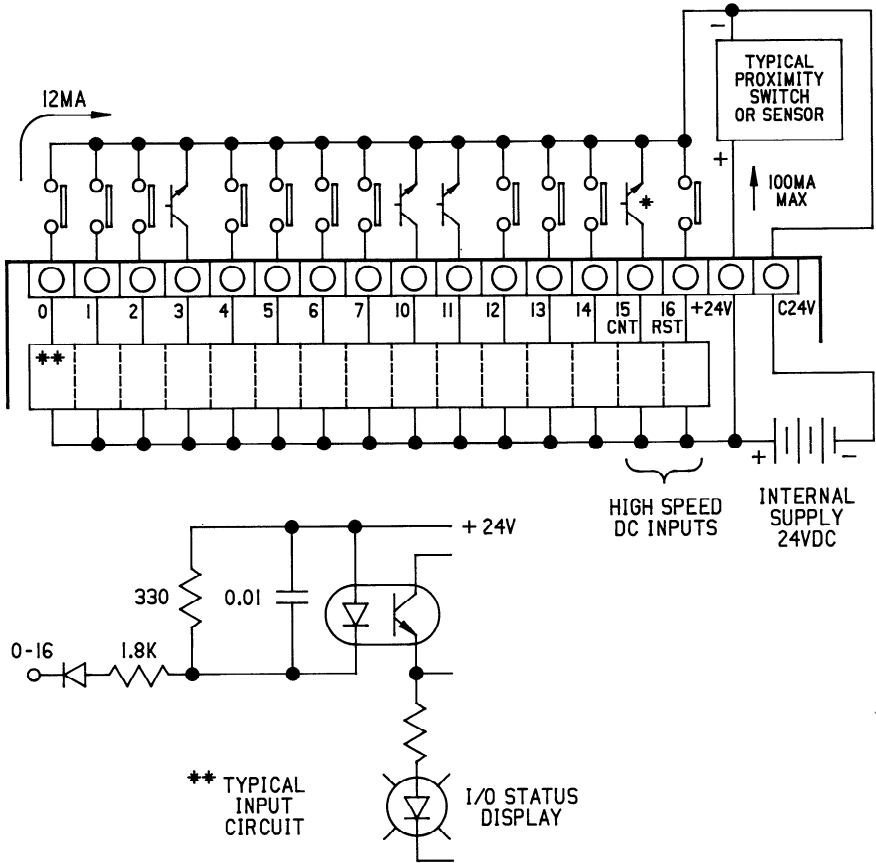

NOTE

* Input 15 must be driven by an open collector device when being used as a high speed counter input. If a normal switch contact were used, switch bounce could cause multiple incorrect input pulses to be counted.

Counter input circuits are dc inputs. Terminals No. 15 and 16 can be used as normal dc sink inputs when not being used as high speed counter inputs.

Figure 6.8 WIRING FOR 24 V dc Sink INPUTS, BASIC UNIT

RELAY OUTPUT CIRCUITS

Output Points	9
Operating Voltage	5-265 V ac/dc
AC Frequency	47-63 Hz
Maximum Current	2 A
Maximum Inrush	See chart below
Maximum Leakage Current	1 mA
Smallest Recommended Load	1 mA @ 5 V
OFF to ON Response	5 ms
ON to Off Response	5 ms
Circuit Indicator	Logic Side
Fuses (Internal, soldered)	2A (C1), 5A (C2, C3)

OPERATING VOLTAGE	MAXIMUM CURRENT FOR LOAD TYPE			TYPICAL LIFE (OPERATIONS)
	RESISTIVE	LAMP	SOLENOID	
220 V ac	2 Amp	0.3 Amp	0.3 Amp	200,000
220 V ac		0.05 Amp	0.05 Amp	800,000
110 V ac		0.3 Amp	0.3 Amp	250,000
110 V ac	2 Amp	0.1 Amp	0.1 Amp	500,000
24 V dc		0.3 Amp		200,000

NOTE

Lamp loads are defined as a X10 inrush with a power factor (PF) of 1.00 and when turned OFF represent a PF of 1.00. Solenoids are defined with a X10 inrush, a PF of 0.65, and when turned OFF represent a PF of 0.35.

NOTE

It is recommended that a 2 amp fuse be placed in series with each output terminal, in order to protect the user load connected to each terminal.

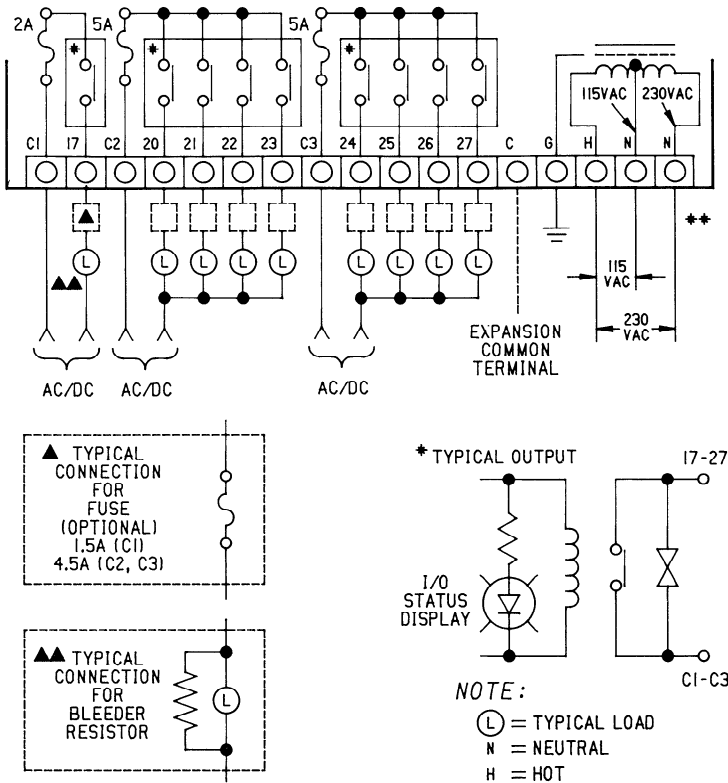

CAUTION

** **DO NOT CONNECT THIS TERMINAL (230 V AC N) UNLESS USING 230 V AC. OTHERWISE DAMAGE TO THE UNIT MAY RESULT.**

NOTE

Since a surge-absorbing circuit is built-in, there is current leakage through the circuit. A bleeder resistor should be attached to prevent incorrect operation in the event that light loads, such as small relays or neon lamps, are used. Leakage may turn on these devices if a bleeder is not used. Refer to Bleeder Resistor Calculation on page 6-7.

Figure 6.9 WIRING FOR RELAY OUTPUTS, BASIC UNIT

24 V dc SOURCE INPUT/RELAY OUTPUT IC609SJR121

This basic unit provides 15 dc source input circuits and 9 relay output circuits. The 15 input circuits are each designed to receive a single discrete (ON/OFF) signal from user supplied devices such as limit switches, pushbuttons, selector switches, and relay contacts. Circuits 15 and 16 can be used for high speed count input and reset or used as normal dc sink input points. The 9 ac output circuits are each capable of controlling user supplied discrete (ON/OFF) loads. Typical loads include relay coils, motor starters, solenoid valves, and indicator lights. Since the relay output circuits were not designed for a specific voltage, such as 24 V dc or 115 V ac, they can be used for a wide variety of loads and signal types. The ON/OFF state of each input and output circuit is indicated by an LED. Figures 6.10 and 6.11 provide wiring information for this unit. Following are specifications for each of the input and output circuits.

DC INPUT CIRCUITS (0-14)

Input Points	15
Maximum Voltage on Input Terminal (no load)	0 V dc
Open Circuit Voltage Of Input (nominal)	24 V dc
Input Current	12 mA
Input Impedance	1.8 K ohms
ON Level	18-26 V dc
OFF Level	0-7 V dc
OFF to ON Response	5-10 ms
ON to OFF Response	5-10 ms
Circuit Indicator	Logic Side
Maximum OFF Leakage	3 mA
Minimum ON Current	6 mA

DC (HIGH SPEED COUNTER) INPUT CIRCUITS (15, 16)

Input Points	2
Input Device	Input 15 must use an open collector device
Maximum Voltage on Input Terminal (no load)	26 V dc
Open Circuit Voltage of Input (nominal)	24 V dc
Input Current	12 mA
Input Impedance	1.8 K ohms
ON Level	0-7 V dc
OFF Level	18-26 V dc
OFF to ON Response	.1 ms
ON to OFF Response	.1 ms
Circuit Indicator	Logic Side
Maximum OFF Leakage	3 mA
Minimum ON Current	6 mA

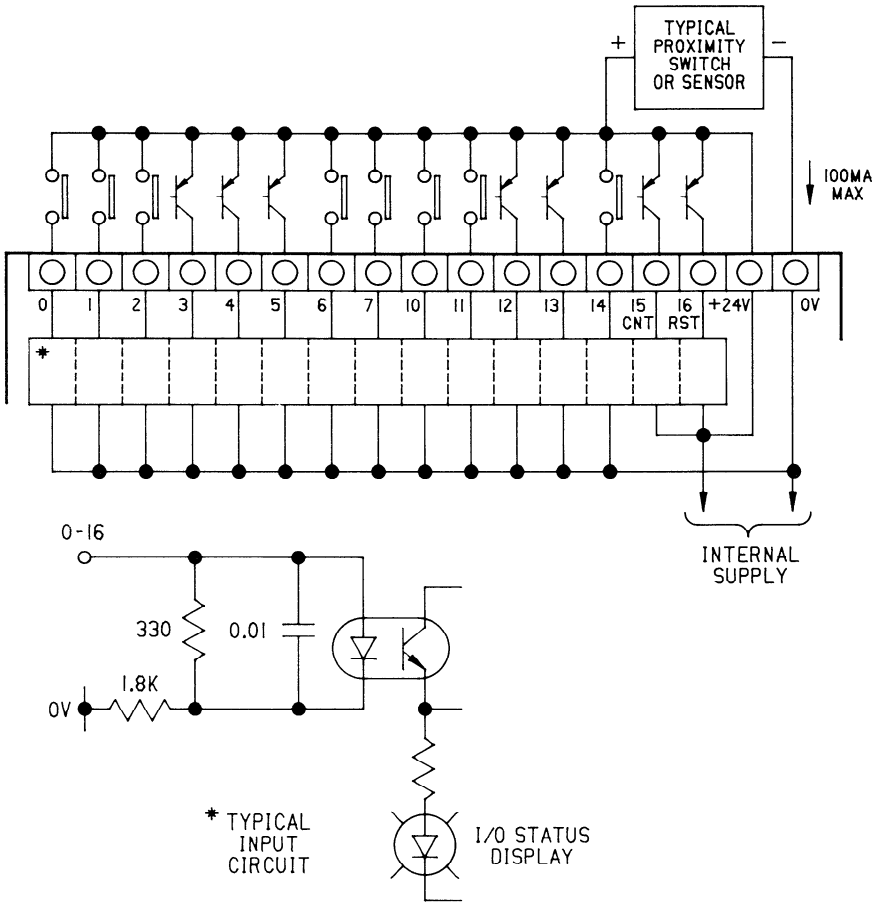

NOTE

Input 15 must be driven by an open collector device when being used as a high speed counter input. If a normal switch contact were used, switch bounce could cause multiple incorrect input pulses to be counted.

Counter input circuits are dc inputs. Terminals No. 15 and 16 can be used as normal dc sink inputs when not being used as high speed counter inputs.

Figure 6.10 WIRING FOR 24 V dc SOURCE INPUTS, BASIC UNIT

RELAY OUTPUT CIRCUITS

Output Points	9
Operating Voltage	5-265 V ac/dc
AC Frequency	47-63 Hz
Maximum Current	2 A
Maximum Inrush	See chart below
Maximum Leakage Current	1 mA
Smallest Recommended Load	1 mA @ 5 V
OFF to ON Response	5 ms
ON to Off Response	5 ms
Circuit Indicator	Logic Side
Fuses (Internal, soldered)	2A (C1), 5A (C2, C3)

OPERATING VOLTAGE	MAXIMUM CURRENT FOR LOAD TYPE			TYPICAL LIFE (OPERATIONS)
	RESISTIVE	LAMP	SOLENOID	
220 V ac	2 Amp	0.3 Amp	0.3 Amp	200,000
220 V ac		0.05 Amp	0.05 Amp	800,000
110 V ac		0.3 Amp	0.3 Amp	250,000
110 V ac		0.1 Amp	0.1 Amp	500,000
24 V dc		0.3 Amp		200,000
	2 Amp			

NOTE

Lamp loads are defined as a X10 inrush with a power factor (PF) of 1.00 and when turned OFF represent a PF of 1.00. Solenoids are defined with a X10 inrush, a PF of 0.65, and when turned OFF represent a PF of 0.35.

NOTE

It is recommended that a 2 amp fuse be placed in series with each output terminal, in order to protect the user load connected to each terminal.

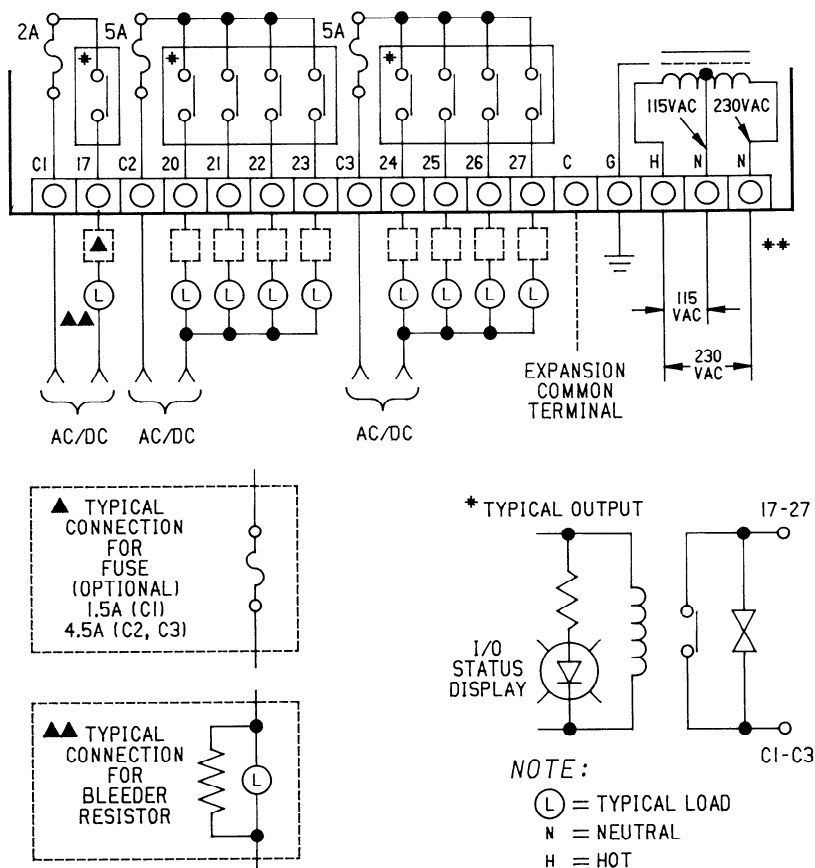

CAUTION

** DO NOT CONNECT THIS TERMINAL (230 V AC N) UNLESS USING 230 V AC. OTHERWISE DAMAGE TO THE UNIT MAY RESULT.

NOTE

Since a surge-absorbing circuit is built-in, there is current leakage through the circuit. A bleeder resistor should be attached to prevent incorrect operation in the event that light loads, such as small relays or neon lamps, are used. Leakage may turn on these devices if a bleeder is not used. Refer to Bleeder Resistor Calculation on page 6-7.

Figure 6.11 WIRING FOR RELAY OUTPUTS, BASIC UNIT

**115 Vac INPUT
IC610MDL125**

This module provides 8 circuits each designed to receive a single discrete (ON/OFF) signal from user supplied devices. Typical input devices include limit switches, pushbuttons, selector switches, and relay contacts. The 8 circuits are divided into two groups of 4 circuits each. Each group can be supplied from a separate power source. Power to operate the field devices must also be supplied by the user. Figure 6.12 provides wiring information for this module. Following are specifications for each of the 8 circuits.

Input Points	8
Operating Voltage	97-132 V ac
AC Frequency	47-63 Hz
Input Current	15 mA @ 60 Hz 11.5 mA @ 50 Hz
Input Impedance	9.5 K ohms
ON Level	Above 80 V ac
OFF Level	Below 20 V ac
OFF to ON Response	10-30 ms
ON to OFF Response	10-60 ms.
Circuit Indicator	Field Side
Internal Power Consumption	10mA @ 9 V dc
Units of Load	1 Unit @ 9 V dc
Weight	5 oz (140 g)

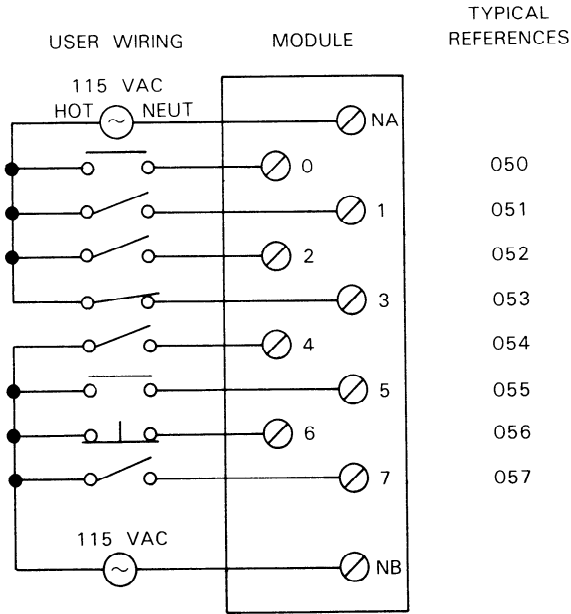

WIRING DIAGRAM

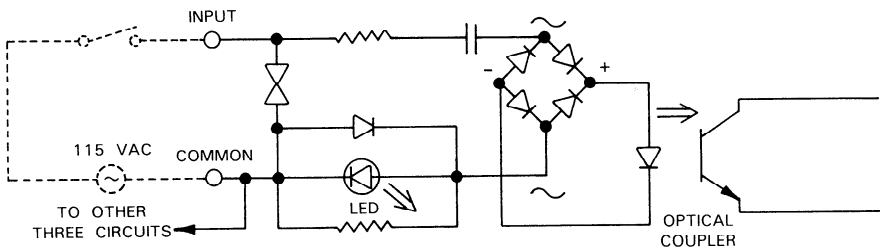

SAMPLE INPUT CIRCUIT

Figure 6.12 WIRING FOR 115 VAC INPUTS

230 V ac INPUT IC610MDL127

This module provides 8 circuits, each designed to receive a single discrete (ON/OFF) signal from user supplied devices. Typical input devices include limit switches, pushbuttons, selector switches, and relay contacts. The 8 circuits are divided into two groups of 4 circuits each. Each of the 2 groups can be supplied from a separate power source. Power to operate the field devices must also be supplied by the user. Following are specifications for each of these 8 circuits.

Input Points	8
Operating Voltage	180-265 V AC
AC Frequency	47-63 Hz
Input Current	18 mA (265V, 60 Hz), Maximum 11 mA, Typical
Input Impedance	18 K ohms @ 60 Hz
ON Voltage	Above 180 V ac
OFF Voltage	Below 40 V ac
OFF Current	< 2 mA
OFF to ON Response	5-50 ms
ON to OFF Response	5-60 ms
Circuit Indicators	Field Side
Internal Power Consumption	10 mA, 9 V dc
Units of LOad	1 Unit @ 9 V dc
Weight	5 oz (140 g)

Field connections are made to screw terminals on a terminal block mounted on the faceplate. Each terminal will accept up to one No. 12 AWG wire or two No. 14 wires. The C1 and C2 common terminals are isolated from each other.

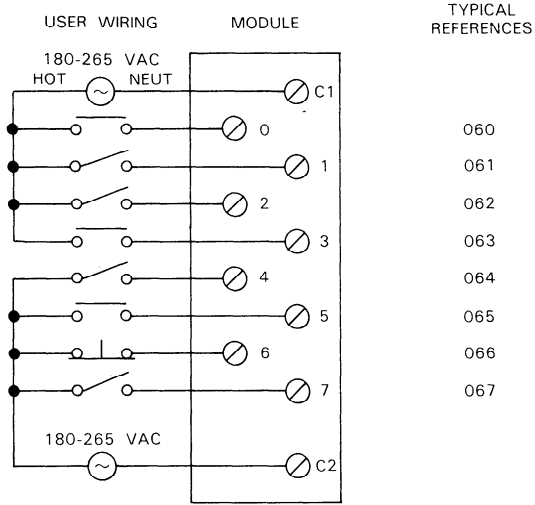

WIRING DIAGRAM

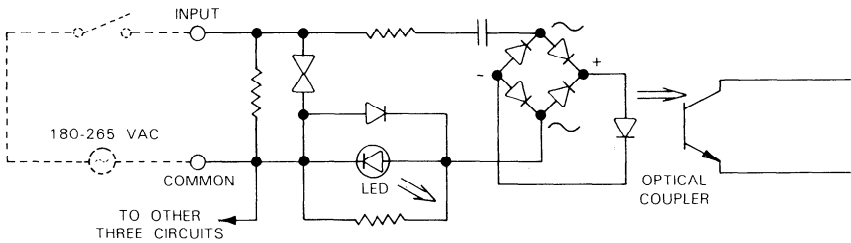

SAMPLE INPUT CIRCUIT

Figure 6.13 WIRING FOR 230 V ac INPUTS

115 V ac ISOLATED INPUT IC610MDL126

This module provides 4 circuits, each designed to receive a single discrete (ON/OFF) signal from user supplied devices. Typical input devices include limit switches, pushbuttons, selector switches, and relay contacts. Each of these circuits is isolated from the other circuits on this module relative to AC power source. The term isolation is not relative to optical-coupler noise and fault isolation which all I/O modules have. Each input is provided with 2 field terminals allowing separate AC power sources (that is, different phases) for each of the four inputs. The sources of AC power must be supplied by the user. Figure 6.14 provides wiring information for this modules.

Although this module consumes 8 discrete references assigned to the I/O slot into which it is inserted, only 4 are actually used. The other 4 can be used internally as coils, but they cannot be provided to hardware I/O modules. Following are specifications for each of the 4 circuits:

Input Points	4
Operating Voltage	97-132 V ac
AC Frequency	47-63 Hz
Input Current	15 ma @ 60 Hz
Input Impedance	10K ohms @ 60 Hz 12K ohms @ 50 Hz
ON Level	Above 80 V ac
OFF Level	Below 20 V ac
OFF to ON Response	10-30 ms
ON to OFF Response	10-60 ms
Circuit Indicator	Field Side
Internal Power Consumption	10 mA @ 9 V dc
Units of Load	1 @ 9 V dc
Weight	4.2 oz (120 g)

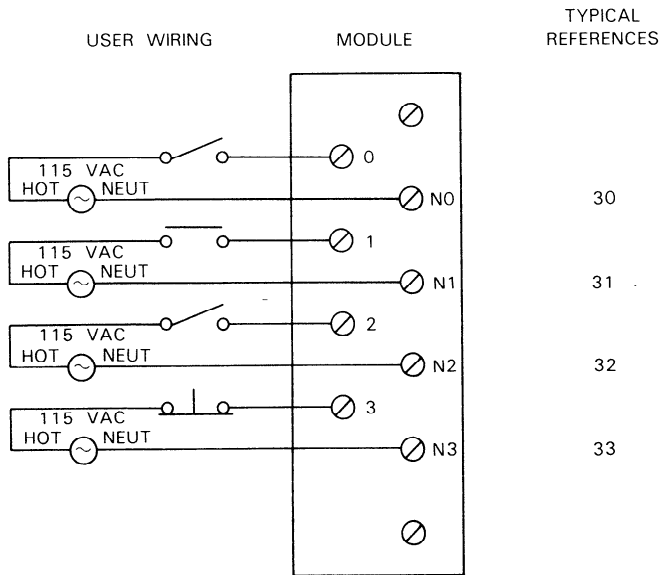

WIRING DIAGRAM

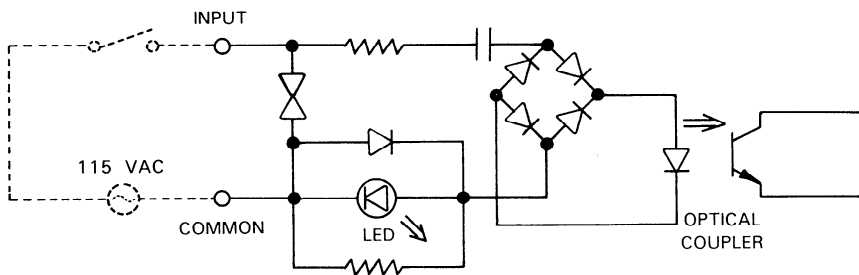

SAMPLE INPUT CIRCUIT

Figure 6.14 WIRING FOR 115 VAC ISOLATED INPUTS

24 V dc SINK INPUT (8 Circuits) IC610MDL101

This module provides 8 circuits each designed to receive a single discrete (ON/OFF) signal from user supplied devices. Typical input devices include limit switches, pushbuttons, selector switches, and relay contacts. Power (24 V dc) to sense the state of these "dry contact" inputs is provided by the rack power supply. No external power source is required with this module. All 8 circuits are powered from this one source. Figure 6.15 provides wiring information for this module. Following are specifications for each of the 8 circuits:

Input Points	8
Maximum Voltage (Open Circuit)	36 V dc
Input Current	18 mA
Input Impedance	1.8 K ohms
ON Level*	< 3 V dc
OFF Level*	> 3 V dc
OFF to ON Response	4-15 ms
ON to OFF Response	4-15 ms
Circuit Indicator	Field Side
Maximum OFF Leakage	3 mA
Minimum ON Current	7 ma
Internal Power Consumption	14 mA for each ON Circuit @ 24 V dc 10 mA @ 9 V dc
Units of Load	1 @ 9 V dc 10 @ 24 V dc
Weight	4.2 oz (120 g)

*Voltage levels measured between common and input terminals (across input device).

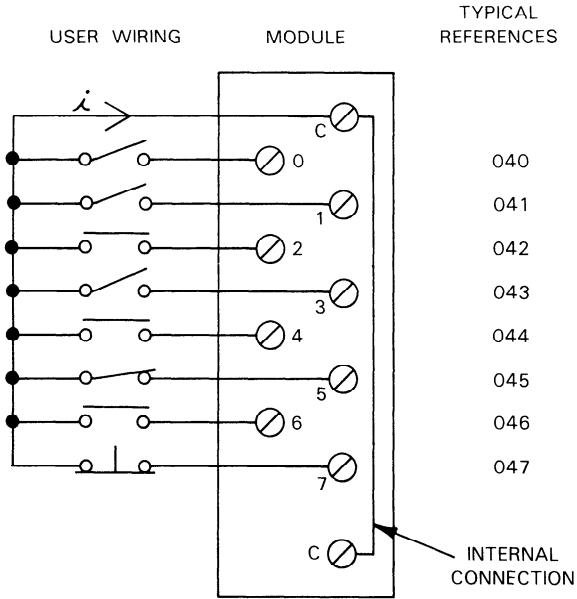

WIRING DIAGRAM

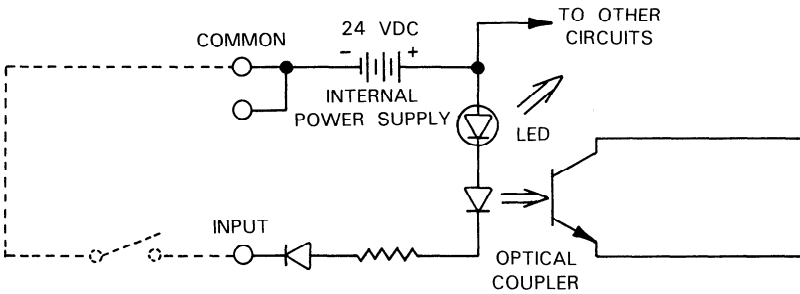

SAMPLE INPUT CIRCUIT

Figure 6.15 WIRING FOR 24 V dc INPUTS

**24 V dc SINK INPUT (16 Circuits)
IC610MDL106**

This module provides 16 circuits, each designed to receive a single discrete (ON/OFF) signal from user supplied devices. This module has 16 LED status indicators to reflect the ON or OFF status of each of the 16 circuits. Typical input devices include limit switches, pushbuttons, selector switches, and relay contacts. 24 V dc power to sense the state of these inputs is provided by the rack power supply; therefore, no external power source is required for this module. All 16 circuits are powered from this one source.

Figure 6.17 provides wiring information for this module. The 16 input circuits are connected to user devices through a 24-pin connector. An optional I/O Interface cable, catalog number IC610CBL105, is available for use with this module. Following are specifications for each of the 16 circuits:

Input Points	16
Maximum Voltage (Open Circuit)	36 V dc
Input Current	16 mA
ON Level	0 to 3 V dc
OFF Level	18 to 36 V dc
OFF to ON Response	4 to 15 ms
ON to OFF Response	4 to 15 ms
Maximum OFF Leakage	2 mA
Minimum ON Current	5 mA
Circuit Indicator	Field side
Internal Power Consumption	24 mA @ 9 V dc, Max. (16 circuits ON)
	210 mA @ 24 V dc, Max. (16 circuits ON)
Units of Load	3 units @ 9 V dc 21 units @ 24 V dc
Weight	4.2 oz (120 g)

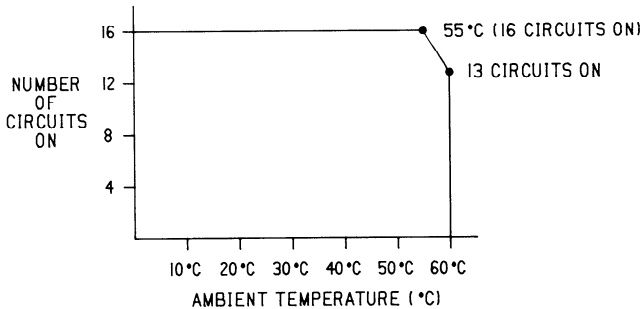
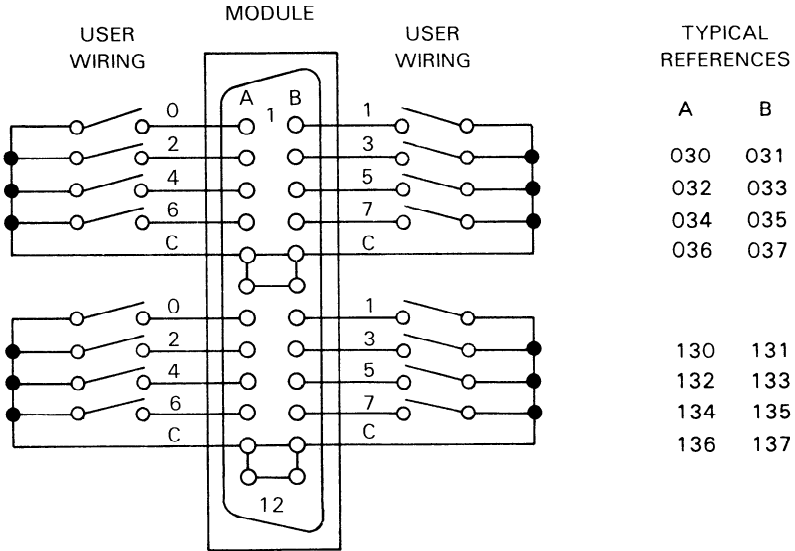

Figure 6.16 I/O POINTS VS. TEMPERATURE CHART



WIRING DIAGRAM

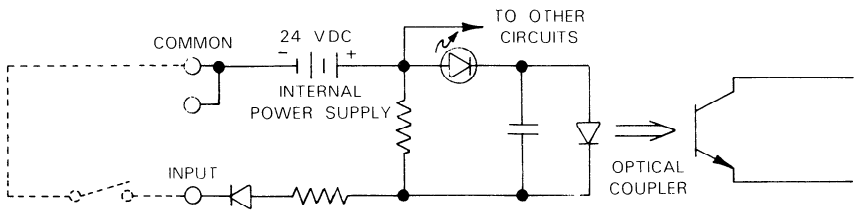

Figure 6.17 WIRING FOR 16 CIRCUIT, 24 V dc SINK INPUT MODULE

**24 V ac/dc SOURCE INPUT
IC610MDL111**

This module provides 8 input circuits, each designed to receive a single discrete (ON/OFF) signal from user supplied devices. Typical input devices include push-buttons, limit switches, selector switches and relay contacts. These input circuits can interface to either 24 V ac signals or 24 V dc source-type signals, thereby allowing the module to interface to input devices that provide their own voltage. Following are specifications for each of the 8 circuits.

	AC Input	DC Input
Input Voltage	20 to 28 V ac, 50-60 Hz	20-28 V dc (Source)
Input Current	19 mA (maximum) 13 mA Typical	19 mA (maximum) 13 mA Typical
ON Level	20 to 28 V ac	20 to 28 V dc
OFF Level	0 to 6 V ac	0 to 6 V dc
OFF to ON Response	5 to 50 ms	6 to 30 ms
ON to OFF Response	5 to 60 ms	5 to 60 ms
Circuit Indicator	Field Side	Field Side
Internal Power Consumption		9 V dc, 10 mA (supplied by rack power supply)
Units of Load		1 @ 9 V dc
Weight		5 oz (140 g)

User devices are connected to screw terminals on the faceplate of this module. Each screw terminal will accept up to one No. 12 AWG wire or two No. 14 AWG wires. The ON/OFF state of each circuit is indicated by an LED located in the field side of each circuit. The 8 circuits are divided into 2 groups of 4, each with its own common. The two commons, CA and CB are isolated from each other internally. Each input can accept either an AC input or a DC input.

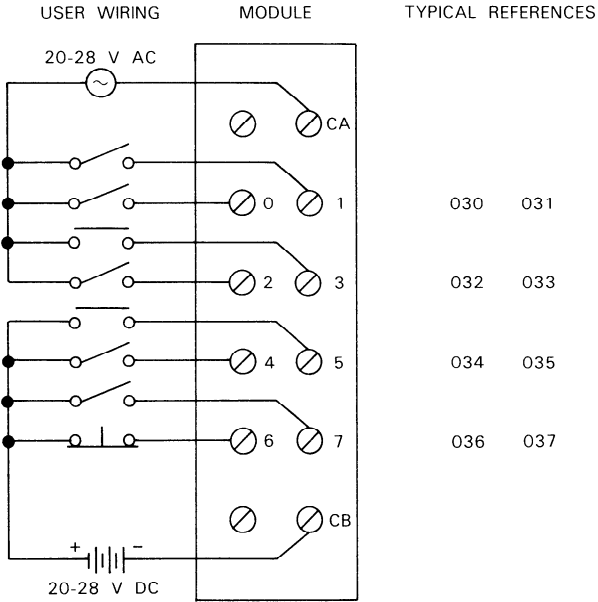

WIRING DIAGRAM

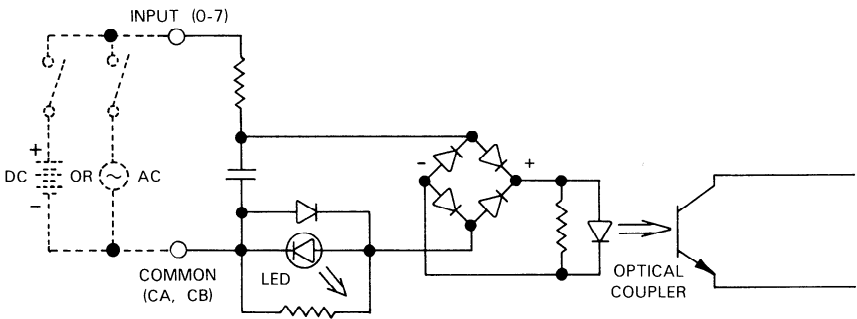

SAMPLE INPUT CIRCUIT

Figure 6.18 WIRING FOR 24 VAC/DC INPUTS

**115/230 V ac OUTPUT
IC610MDL175**

This module provides 8 circuits each capable of controlling user supplied discrete (ON/OFF) loads. Typical loads include relay coils, motor starters (up to No. 3), solenoid valves and indicator lights. The 8 circuits are divided into 2 groups of 4 circuits each. Each group can be supplied from a separate power source. Power to operate the field devices must also be supplied by the user. Figure 6.20 provides wiring information for this module. Following are specifications for each of the 8 circuits:

Output Points	8
Operating Voltage	97-265 V ac
AC Frequency	47-63 Hz
Maximum Current*	1 amp
Maximum Leakage Current	1.2 mA @ 220V, 60 Hz 0.5 mA @ 110V, 60 Hz
ON Voltage Drop	0.9V @ 1 amp 0.8V @ 0.5 amp
Smallest Recommended Load	25 mA
Maximum Inrush	10 amps for 16 ms 5 amps for 100 ms
OFF to ON Response	1 ms
ON to OFF Response	8-10 ms (1/2 cycle)
Circuit Indicator	Logic Side
Fuses (Internal, Soldered)	(2) 10 amp (one on each group of 4)
Internal Power Consumption	20 mA for each ON Circuit @ 9 V dc
Units of Load	16 @ 9 V dc
Weight	6.4 oz (180 g)

*Maximum load current is dependent upon ambient temperature as shown on the chart in Figure 6.19.

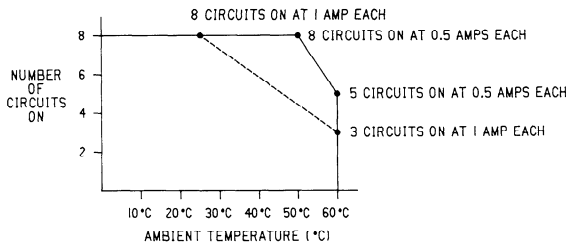
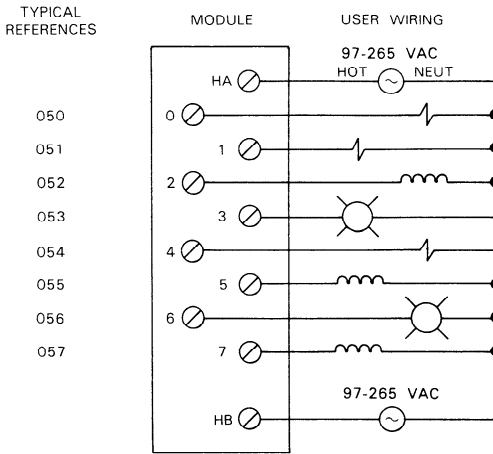

Figure 6.19 I/O POINTS VS. TEMPERATURE CHART



WIRING DIAGRAM

CAUTION

IF THIS MODULE IS WIRED INCORRECTLY OR THE LISTED SPECIFICATIONS ARE EXCEEDED, ANY DAMAGE INCURRED BY THE MODULE, OR USER DEVICES CONNECTED TO THE MODULE MAY NOT BE COVERED BY WARRANTY.

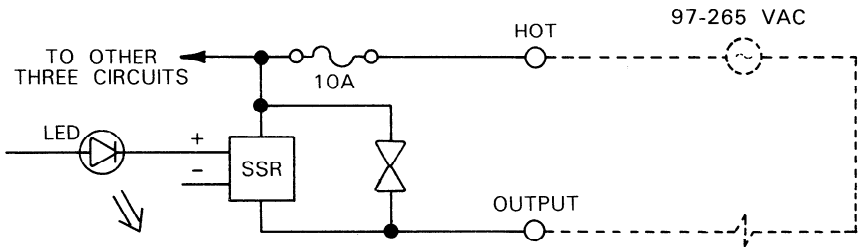

SAMPLE OUTPUT CIRCUIT

Figure 6.20 WIRING FOR 115 V ac OUTPUTS

**115/230 V ac ISOLATED OUTPUT
IC610MDL176**

This module provides 4 circuits each capable of controlling user supplied discrete (ON/OFF) loads. Typical loads include relay coils, motor starters (up to No. 4), solenoid valves, and indicator lights. Each of these circuits is isolated from the other circuits on this module relative to AC power source. The term isolation is not relative to optical-coupler noise and fault isolation which all I/O modules have. Each output is provided with 2 field terminals allowing separate AC power sources (that is, different phases) for each of the 4 outputs. These power sources must be supplied by the user. Figure 6.22 provides wiring information for this module. Although this module consumes 8 discrete references assigned to the slot into which it is placed, only 4 are actually used. The other 4 can be used internally as coils, but they cannot be provided to hardware I/O modules. Following are specifications for each of the four circuits:

Outputs	4
Operating Voltage	97-265 V ac
AC Frequency	47-63 Hz
Maximum Current*	2 amps
Maximum Leakage Current	7 mA @ 220V, 60 Hz 3.5 mA @ 110V
ON Voltage Drop	.8V @ 2 amps
Smallest Recommended Load	25 mA
OFF to ON Reponse	1.0 ms
ON to OFF Response	8-10 ms (1/2 Cycle)
Circuit Indicator	Logic Side
Fuses (Internal)	(4) 3 amp (each circuit, Replaceable)
Internal Power Consumption	12 mA @ 9 V dc
Units of Load	8 units @ 9 V dc
Weight	5 oz (140 g)

*Maximum load current is dependent upon ambient temperature as shown on the chart in Figure 6.21.

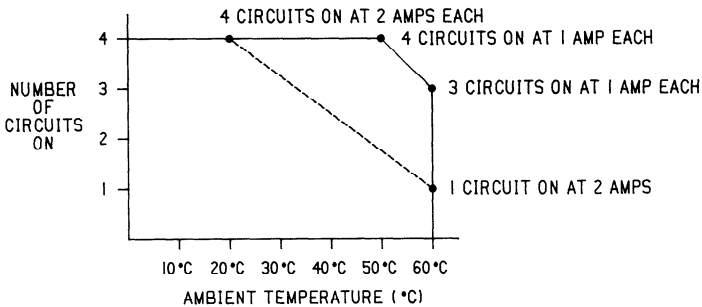
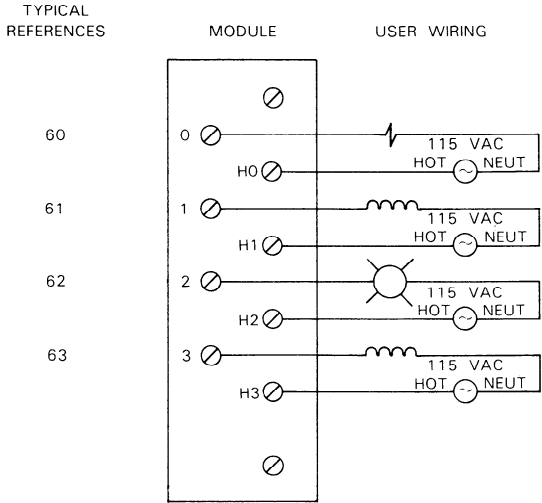
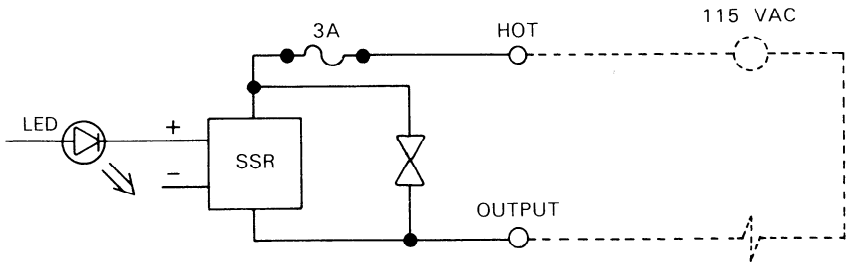

Figure 6.21 I/O POINTS VS. TEMPERATURE CHART



WIRING DIAGRAM



SAMPLE OUTPUT CIRCUIT

Figure 6.22 WIRING FOR 115 V ac ISOLATED OUTPUTS

**24 V dc SINK OUTPUT (8 Circuits)
IC610MDL151**

This module provides 8 circuits each capable of controlling user supplied discrete (ON/OFF) loads. Typical loads include relay coils, motor starters, solenoid valves, and indicator lights. The 8 circuits are provided referenced to a single DC power source, that must be supplied by the user. Figure 6.24 provides wiring information for this module. Since current flows from the load into the field terminal for each circuit when the output is energized, these circuits are referred to as sink DC outputs. Following are specifications for each of the 8 circuits:

Output Points	8
Operating Voltage	5-24 V dc
Peak Voltage	45 V dc
Maximum Current*	0.5 amp
Max. Leakage Current	0.1 mA @ 40 V dc
ON Voltage Drop	0.8V @ 0.5 amp 0.65V @ 0.1 amp
Smallest Recommended Load	1 mA
Maximum Inrush	3 amp for 20 ms 1 amp for 100 ms
OFF to ON Response	100 μ s
ON to OFF Response	100 μ s
Circuit Indicator	Logic Side
Fuses (Internal)	(2) 3 amp (one on each group of 4)
Internal Power Consumption	20 mA @ 9 V dc. 3 mA for each ON Circuit @ 24 Vdc
Units of Load	2 units @ 9 V dc 3 units @ 24 V dc
Weight	4.2 oz (120 g)

*Maximum load current is dependent upon ambient temperatures as shown in Figure 6.23.

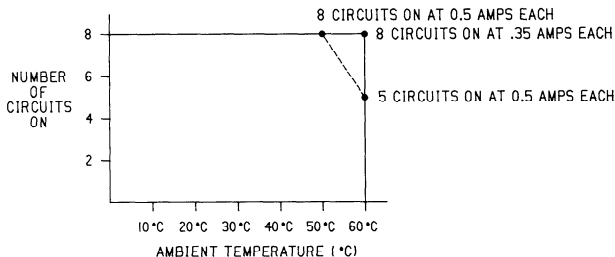
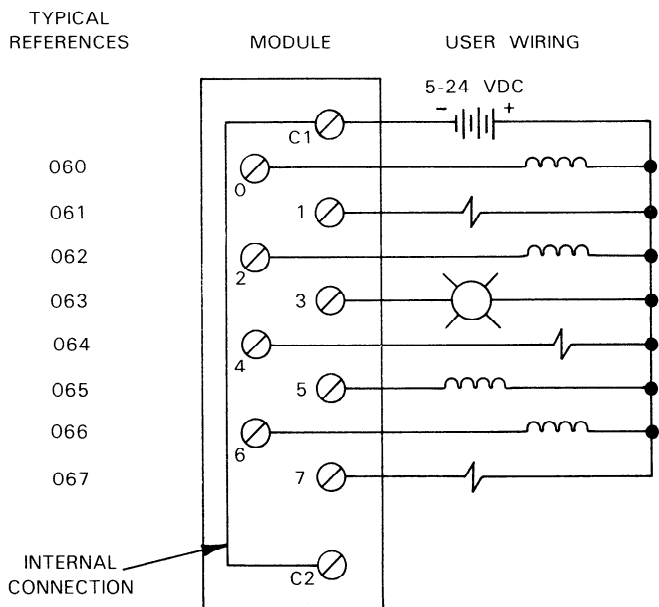
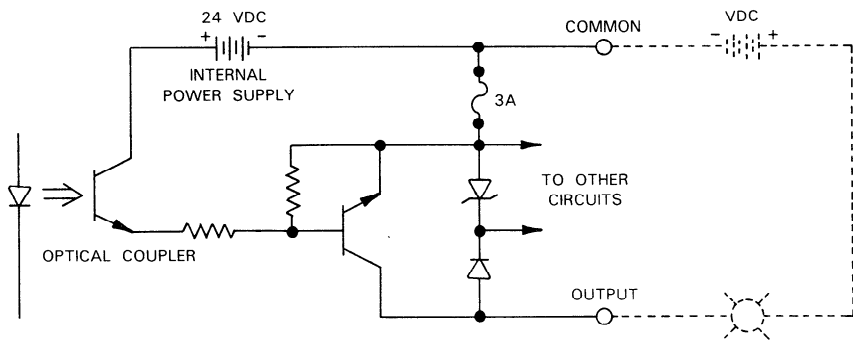

Figure 6.23 I/O POINTS VS TEMPERATURE CHART



WIRING DIAGRAM



SAMPLE OUTPUT CIRCUIT

Figure 6.24 WIRING FOR 24 VDC SINK OUTPUTS

**24 V dc SINK OUTPUT (16 Circuits)
IC610MDL156**

This module provides 16 circuits, each designed to be capable of controlling user supplied discrete (ON/OFF) loads. There are 16 LEDs on the faceplate, which are status indicators to reflect the ON or OFF status of each of the circuits. Typical loads include relay coils, motor starters, solenoid valves, and indicator lights. The 16 circuits are referenced to a single DC power source that must be supplied by the user. Output switching capacity of this module is 0.5 A at 24 V dc. The output switching circuitry is arranged in 4 groups with 4 circuits in each group. Each group is protected by a 3 amp fuse.

The 16 circuits are connected to user loads through an optional I/O Interface cable, Catalog number IC610CBL105, which connects to a 24-pin connector mounted on the module faceplate. Figure 6.26 provides wiring information for this module. Following are specifications for each of the 16 circuits.

Output Points	16
Operating Voltage	5-24 V dc
Peak Voltage	40 V dc
ON Voltage Drop, Typical	0.9 V dc @ 0.5 amp
ON Voltage Drop, Maximum	1.5 V dc @ 0.5 amp
Maximum Current*	0.5 amp
Maximum Leakage Current	0.1 mA @ 40 V dc
Maximum Inrush	3 amp for 20 ms 1 amp for 100 ms
OFF to ON Response	0.1 ms
ON to OFF Response	0.1 ms
Fuse (Internal)	3 amp (In Output Common Line, one for each group of 4).
Internal Power Consumption	40 mA @ 9 V dc, Maximum (16 outputs ON) 96 mA @ 24 V dc, Maximum (16 outputs ON)
Units of Load	4 units @ 9 V dc 10 units @ 24 V dc
Weight	3.9 oz (110 g)

* Maximum load current is dependent upon ambient temperature as shown in Figure 6.25.

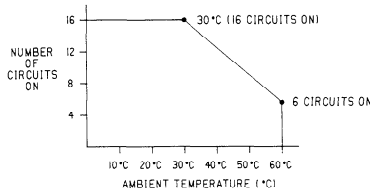
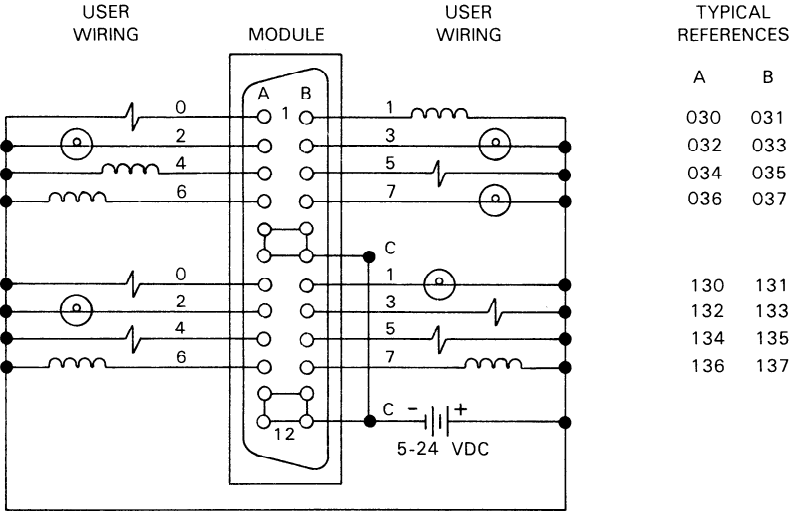
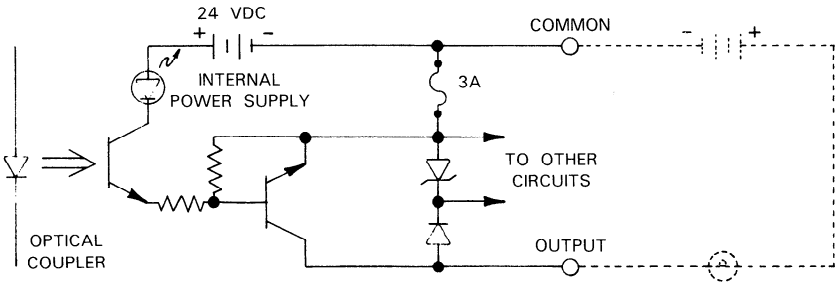

Figure 6.25 I/O POINTS VS TEMPERATURE CHART



WIRING DIAGRAM



SAMPLE OUTPUT CIRCUIT

Figure 6.26 WIRING FOR 16 CIRCUIT 24 V dc SINK OUTPUTS

**24 V dc 2 AMP SINK OUTPUT
IC610MDL153**

This module provides 4 fused 24 V dc sink output circuits each capable of controlling user supplied discrete (ON/OFF) loads. Each circuit is rated at 2 amps continuous current. Typical loads include motor starters, relay coils, solenoid valves, and indicator lights. The circuits on this module are referred to as sink outputs since current flows from the load into the field terminal for each circuit when the output is energized. Field connections are made to screw terminals on a terminal block mounted on the faceplate. Each terminal will accept up to one No. 12 AWG wire or two No. 14 AWG wires. The ON/OFF state of each circuit is indicated by a corresponding LED. This module, although having only 4 output circuits, will consume 8 consecutive discrete references. The 4 references not available as "real world" outputs can be used as internal coils. Following are specifications for each of the four output circuits.

Output Points	4
Operating Voltage	5 to 24 V dc
Peak Voltage	45 V dc
ON Voltage Drop	.15 V dc @ 1 amp .6 V dc @ 4 amp
Maximum Current*	2 amps
Maximum Leakage Current	<.4 mA @ 40 V dc
OFF to ON Response	.1 ms
ON to OFF Response	.1 ms
Circuit Indicator	Logic Side
Fuses, Internal	5 amp (1 for each circuit) Replaceable
Internal Power Consumption	5 mA @ 24 V dc 12 mA @ 9 V dc
Units of Load	1 unit @ 24 V dc 2 units @ 9 V dc
Weight	4.2 oz (120 g)

*Maximum load current is dependent on ambient temperature as shown in Figure 6.27.

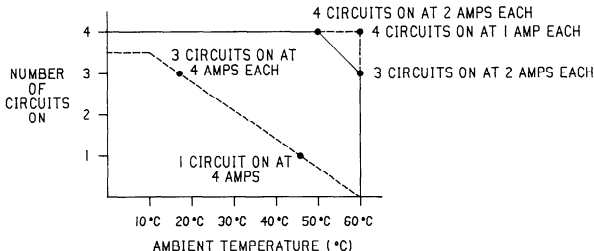
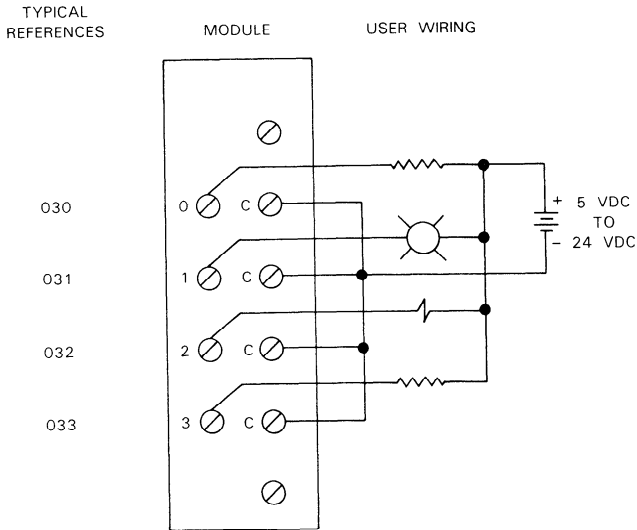
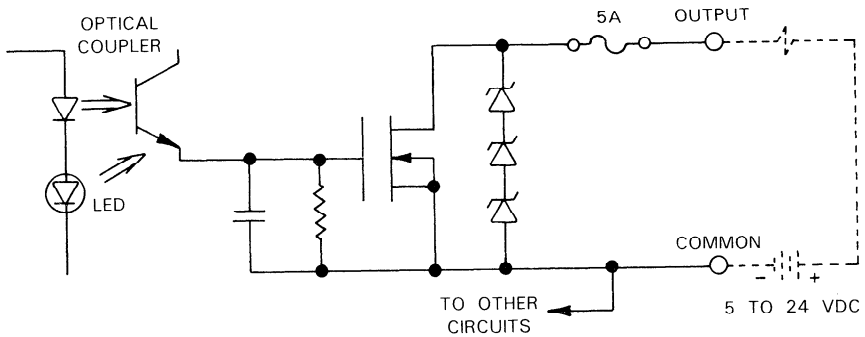

Figure 6.27 I/O POINTS VS TEMPERATURE CHART



WIRING DIAGRAM



SAMPLE SINK OUTPUT CIRCUIT

Figure 6.28 WIRING FOR 24 V dc 2 AMP SINK OUTPUTS

**24 V dc 2 AMP SINK/SOURCE OUTPUT
IC610MDL154**

This module provides 4 isolated, fused 24 V dc sink or source output circuits each capable of controlling user supplied discrete (ON/OFF) loads. Each circuit is rated at 2 amps continuous current. Outputs can be connected in parallel to increase output current capacity. Types of loads that can be controlled by this module would include motor starters, relay coils solenoid valves, and indicator lights. All 4 circuits can be referenced to a separate DC source of power. The circuits on this module can be used as either source outputs or sink outputs, depending on how the load is wired in relation to the load power supply.

Field connections are made to screw terminals on a terminal block mounted on the faceplate. Each terminal will accept up to one No. 12 AWG wire or two No. 14 AWG wires. The ON/OFF state of each circuit is indicated by a corresponding LED on the logic side. This module will consume 8 consecutive discrete references. The 4 references not used as "real world" outputs can be used as internal coils in your program. Following are specifications for each of the four circuits.

Output Points	4
Operating Voltage	5 to 24 V dc
Peak Voltage	45 V dc
Maximum Current*	2 amps Continuous 8 amps Maximum Peak
Maximum Leakage Current	.4 mA @ 40 V dc
ON Voltage Drop	1 V dc @ 6 amps .6 V dc @ 4 amps .3 V dc @ 2 amps .15 V dc @ 1 amp
OFF to ON Response	.1 ms
ON to OFF Response	.1 ms
Circuit Indicator	Logic Side
Fuses, Internal	5 amp (1 for each circuit) Replaceable
Internal Power Consumed	12 mA @ 9 V dc 30 mA @ 24 V dc
Units of Load	2 units @ 9 V dc 3 units @ 24 V dc

Lamp load should be .8 amps or less.

*Load current (max.) is dependent on ambient temperature as shown below.

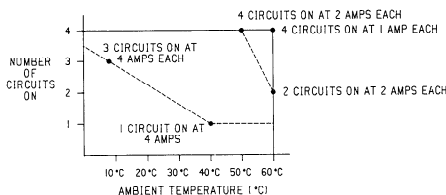
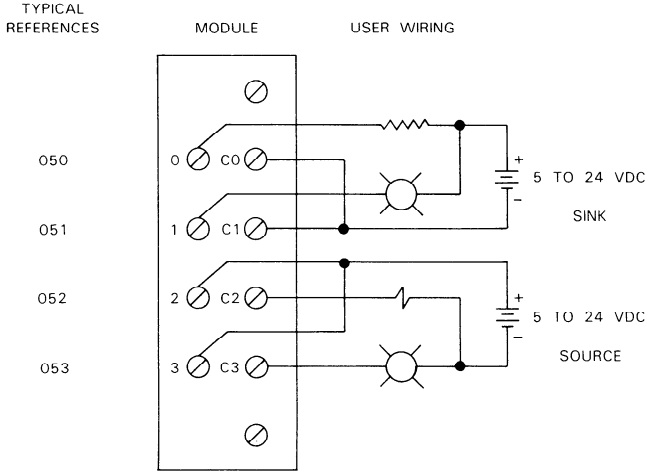
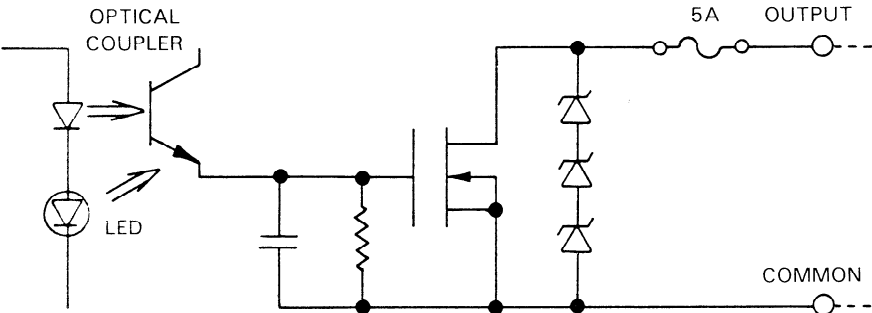

Figure 6.29 I/O POINTS VS. TEMPERATURE CHART



Although not shown as such, the 4 circuits are isolated from each other and can be connected to separate power sources.

WIRING DIAGRAM



SAMPLE OUTPUT CIRCUIT

Figure 6.30 WIRING OF 24 V dc 2 AMP SINK/SOURCE OUTPUT

**24 V dc SOURCE OUTPUT
IC610MDL155**

This module provides eight 24 V dc source output circuits, each capable of controlling user supplied discrete (ON/OFF) loads. Each circuit is rated at 0.5 amps continuous current. Typical loads that can be controlled by this module are motor starters, relay coils, solenoid valves, and indicator lights. The output switching circuits on the module are arranged in 2 groups with 4 circuits in each group. Each group of 4 output circuits is protected by a 3 amp fuse. All 8 circuits should be referenced to a single source of dc power. Field connections are made to screw terminals on a terminal block mounted on the module's faceplate. Each terminal will accept up to one No. 12 AWG wire or two No. 14 AWG wires. The operating state, either ON or OFF, is indicated by a corresponding LED viewed on the module's faceplate. Following are specifications for each of the 8 circuits.

Output Points	8
Operating Voltage	5 to 24 V dc
Peak Voltage	40 V dc
ON Voltage Drop	1.0 V @ 0.5 amp 0.75 V @ 0.1 amp
Maximum Current*	0.5 amps
Maximum Leakage Current	0.1 mA at 24 V dc
Smallest Recommended Load	1.0 mA
OFF to ON Response	100µs
ON to OFF Response	100µs
Circuit Indicator	Logic Side
Fuses (Internal)	(2) 3 amp (in output common line, one for each group of 4 circuits)
Internal Power Consumption	30 mA maximum @ 9 V dc, Supplied by rack power supply
Units of Load	3 Units @ 9 V dc
Weight	4.2 oz (120 g)

*Maximum load current is dependent on ambient temperature as shown in Figure 6.31.

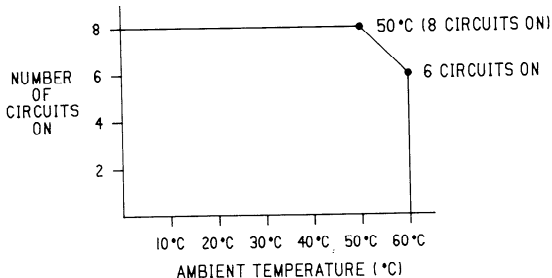
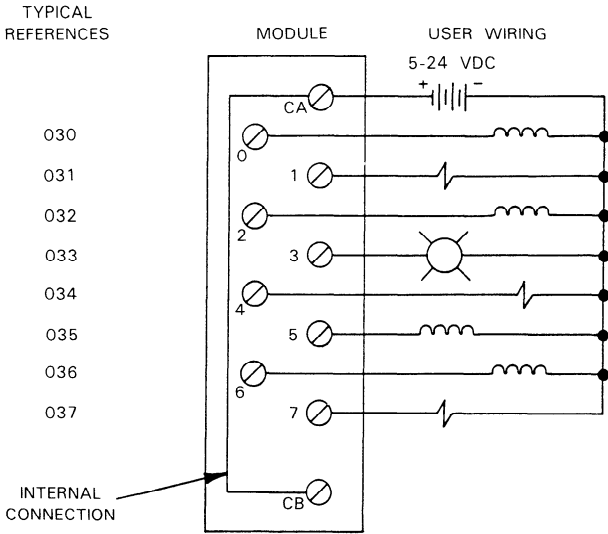
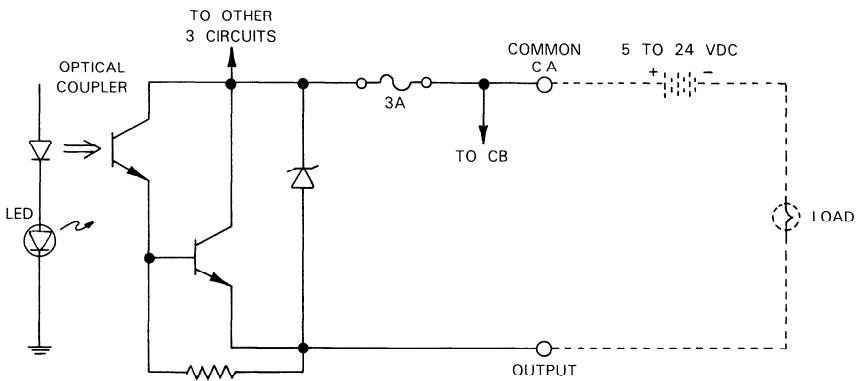

Figure 6.31 I/O POINTS VS. TEMPERATURE CHART



WIRING DIAGRAM



SAMPLE OUTPUT CIRCUIT

Figure 6.32 WIRING FOR 24 V dc SOURCE OUTPUTS

**RELAY OUTPUT
IC610MDL180**

This module provides 8 circuits each capable of controlling user supplied discrete (ON/OFF) loads. Typical loads include relay coils, motor starters, solenoid valves, and indicator lights. Since this module is not designed for a specific current type such as 115 V ac or 24 V dc, it can be used with a wide variety of loads and signal types. The 8 circuits are divided into two groups of 4 circuits each. Each group can be supplied from a separate power source. Power to operate the field devices must also be supplied by the user. Following are specifications for each of the eight circuits:

Outputs	8
Operating Voltage	5 to 265 V ac/dc
AC Frequency	47-63 Hz
Maximum Current*	4 amp (resistive)
Maximum Leakage Current (Across Contacts)	1 mA
Smallest Recommended Load	5 mA
Maximum Inrush	5 amps
OFF to ON Reponse	5 ms.
ON to OFF Response	5 ms
Circuit Indicator	Logic Side
Fuses (Internal)	(2) 10 amp (Replaceable) (one for each group of 4)
Internal Power Consumption	45 mA for each ON Circuit @ 9 Vdc
Units of Load	34 units @ 9 V dc
Weight	7 oz (200 g)

*Since non-solid state devices are used as the power switching devices, the following limitations must be observed for reliable operation:

Table 6.2 MAXIMUM CURRENT VS. LOAD TYPE FOR RELAY OUTPUTS

OPERATING VOLTAGE	MAXIMUM CURRENT FOR LOAD TYPE			TYPICAL LIFE (OPERATIONS)
	RESISTIVE	LAMP	SOLENOID	
220 V ac	4 Amp	0.5 Amp	0.5 Amp	100,000
220 V ac	.05 Amp	.05 Amp		800,000
110 V ac	4 Amp	0.5 Amp	0.5 Amp	150,000
110 V ac	0.1 Amp	0.1 Amp		650,000
24 V dc	5 Amp	0.5 Amp	0.5 Amp	100,000
50 V dc	1 Amp	0.1 Amp	0.1 Amp	100,000
100 V dc	0.5 Amp	.05 Amp	.05 Amp	100,000
250 V dc	0.3 Amp	.03 Amp	.03 Amp	100,000

NOTE

Lamp loads are defined as a X10 inrush with a power factor (PF) of 1.00 and when turned OFF represent a PF of 1.00. Solenoids are defined with a X10 inrush, a PF of 0.65, and when turned OFF represent a PF of 0.35.

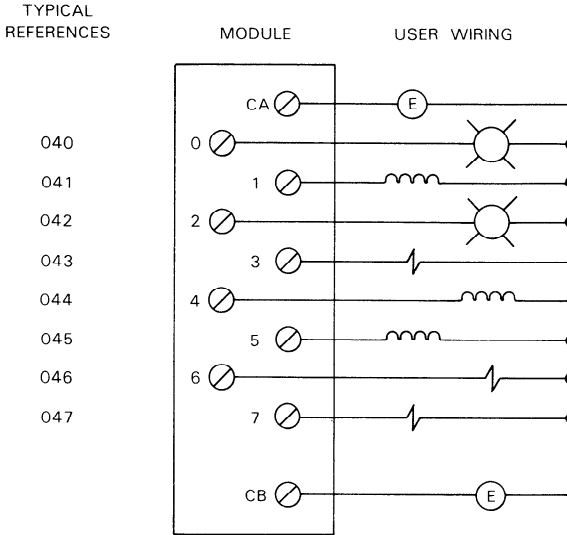

WIRING DIAGRAM

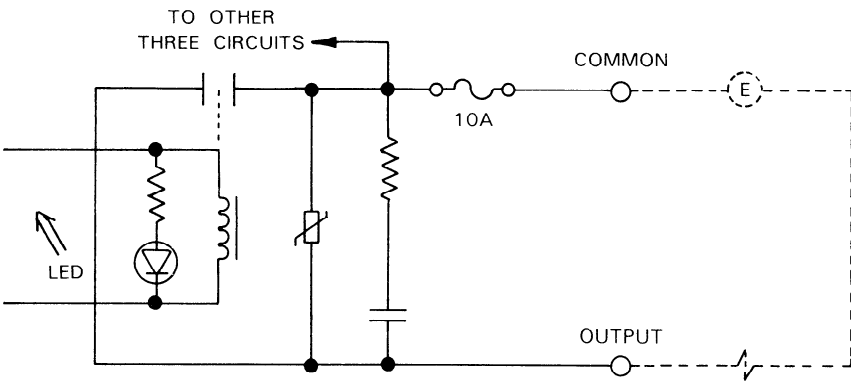

SAMPLE OUTPUT CIRCUIT

Figure 6.33 WIRING FOR RELAY OUTPUTS

24 V dc INPUT/OUTPUT (4 IN/4 OUT) IC610MDL103

This module provides a dual function since it provides 4 input circuits each designed to receive a single discrete (ON/OFF) signal from user supplied devices and 4 output circuits each capable of controlling user supplied discrete (ON/OFF) loads. Typical input devices include limit switches, pushbuttons, selector switches, and relay contacts. Typical loads include relay coils, motor starters, solenoid valves, and indicator lights.

24 V dc power to sense the state of the inputs is provided by the rack power supply. The 4 output circuits are referenced, through their respective loads, to a single DC power source. The ON/OFF state of each input and output circuit is indicated by an LED. Figure 6.34 provides wiring information for this module. Following are specifications for each of the 4 input and 4 output circuits:

INPUT CIRCUITS

Input Points	4
Maximum Voltage (Open Circuit)	36 V dc
Input Current	18 mA
ON Level	0-3 V dc
OFF Level	18-36 V dc
OFF to ON Response	4-15 ms
ON to OFF Response	4-15 ms
Maximum OFF Leakage	3 mA
Minimum ON Current	7 mA

OUTPUT CIRCUITS

Output Points	4
Operating Voltage	5-24 V dc
Peak Voltage	45 V dc
Maximum Current	0.5 amp
Maximum Leakage Current	0.1 mA @ 40 V dc
ON Voltage Drop (Typical)	0.8 V dc @ 0.5 amp
[is.65 Vdc @ .1 amp	
ON Voltage Drop (Max)	1.5 V dc @ 0.5 amp
OFF to ON Response	0.1 ms
ON to OFF Response	0.1 ms
Fuse (Internal)	3 amp (In Output common line)
Internal Power Consumption	20 mA @ 9 V dc
Inputs	14 mA for each On Circuit
Outputs	3 mA for each On Circuit
Units of Load	2 units @ 9 V dc 7 units @ 24 V dc
Weight	4.6 oz (130 g)

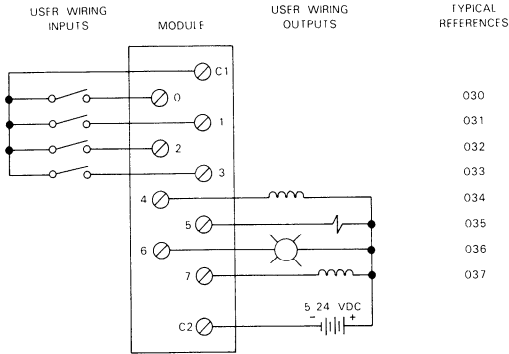

WIRING DIAGRAM

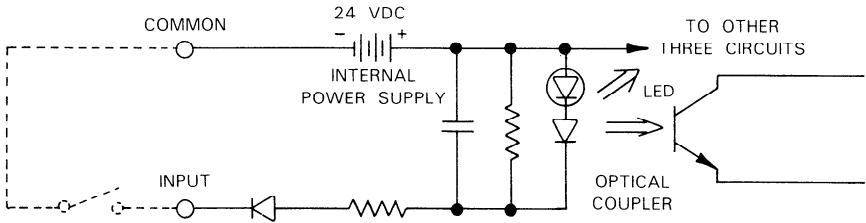

SAMPLE INPUT CIRCUIT

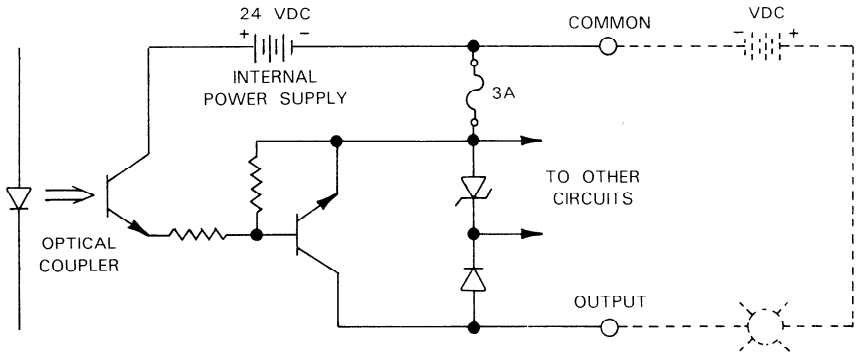

SAMPLE OUTPUT CIRCUIT

Figure 6.34 WIRING FOR 24 V dc INPUTS/OUTPUTS

24 V dc INPUT/RELAY OUTPUT (4 IN/4 OUT) IC610MDL104

This module provides 4 dc input circuits and 4 relay output circuits. The 4 input circuits are each designed to receive a single discrete (ON/OFF) signal from user supplied devices such as limit switches, pushbuttons, and relay contacts. The 4 relay output circuits are each capable of controlling user supplied discrete (ON/OFF) loads. Typical loads include relay coils, motor starters, and indicator lights. Since the relay output circuits were not designed for a specific current type, such as 24 V dc or 115 V ac, they can be used for a wide variety of loads and signal types. The ON or OFF state of each input and output circuit is indicated by an LED. Figures 6.35 and 6.36 provide wiring information for this module. Following are specifications for each input and output circuit.

DC INPUT CIRCUITS

Input Points	4
Maximum Voltage	36 V dc
Input Current	18 mA (max)
ON Level	0-3 V dc
OFF Level	18-36 V dc
OFF to ON Response	4-15 ms
ON to OFF Response	4-15 ms
Maximum OFF Leakage	3 mA
Minimum ON Current	7 mA

RELAY OUTPUT CIRCUITS

Outputs	4
Operating Voltage	5 to 265 V ac/dc
AC Frequency	47-63 Hz
Maximum Current*	4 amp (resistive)
Maximum Leakage Current (Across Contacts)	1 mA
Smallest Recommended Load	5 mA
Maximum Inrush	5 amps
OFF to ON Response	5 ms
ON to OFF Response	5 ms
Circuit Indicator	Logic Side
Fuse (In Output Common Line, Replaceable)	10 amp
Internal Power Consumption	45 mA for each ON Circuit @ 9 V dc
Units of Load	20 units @ 9 V dc 6 units @ 24 V dc

*Since non-solid state devices are used as the power switching devices, the limitations listed in Table 6.3 must be observed for reliable operation:

Table 6.3 MAXIMUM CURRENT VS. LOAD TYPE FOR RELAY OUTPUTS

OPERATING VOLTAGE	MAXIMUM CURRENT FOR LOAD TYPE			TYPICAL LIFE (OPERATIONS)
	RESISTIVE	LAMP	SOLENOID	
220 V ac	4 Amp	0.5 Amp	0.5 Amp	100,000
220 V ac	0.05 Amp	0.05 Amp		800,000
110 V ac	4 Amp	0.5 Amp	0.5 Amp	150,000
110 V ac	0.1 Amp	0.1 Amp		650,000
24 V dc	5 Amp	0.5 Amp	0.5 Amp	100,000
50 V dc	1 Amp	0.1 Amp	0.1 Amp	100,000
100 V dc	0.5 Amp	.05 Amp	.05 Amp	100,000
250 V dc	0.3 Amp	.03 Amp	.03 Amp	100,000

NOTE

Lamp loads are defined as a X10 inrush with a power factor (PF) of 1.00 and when turned OFF represent a PF of 1.00. Solenoids are defined with a X10 inrush, a PF of 0.65, and when turned OFF represent a PF of 0.35.

Figure 6.35 illustrates typical wiring of user input devices and loads to this module.

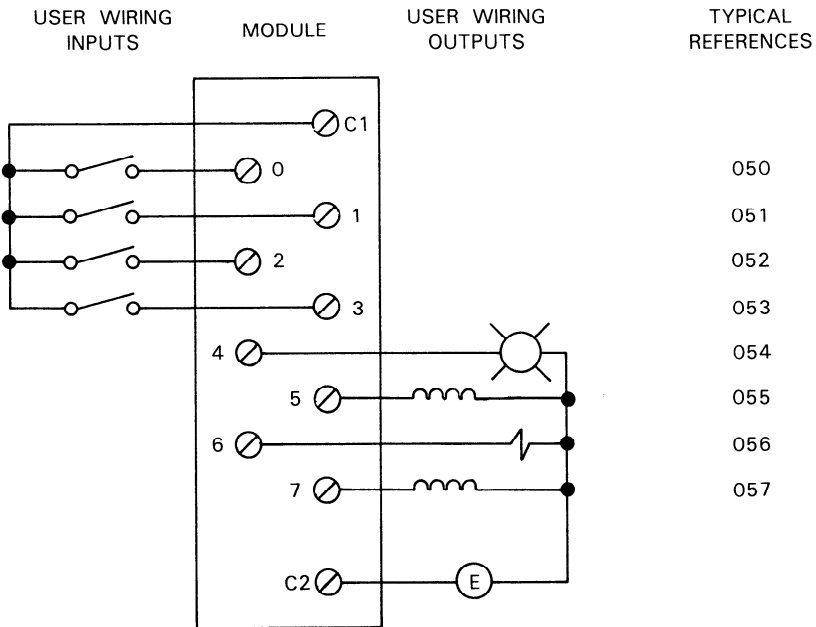
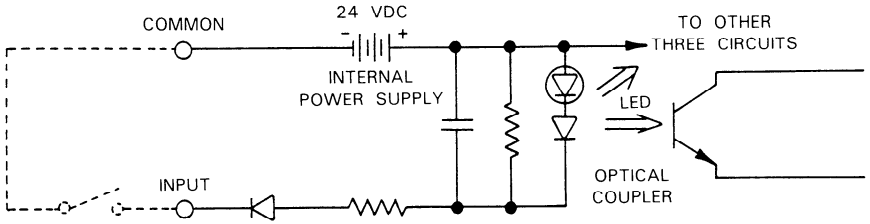
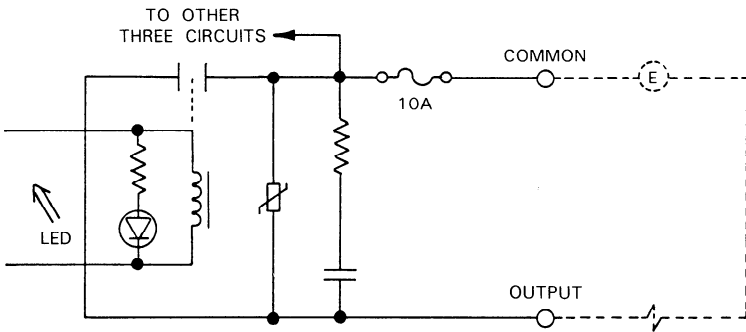

Figure 6.35 TYPICAL WIRING DIAGRAM

Figure 6.36 is an illustration showing a sample input and output circuit. Each sample circuit is 1 of 4 of each type.



SAMPLE INPUT CIRCUIT



SAMPLE RELAY OUTPUT CIRCUIT

Figure 6.36 SAMPLE 24 V dc INPUT/RELAY OUTPUT CIRCUITS

**FAST RESPONSE I/O
IC610MDL115**

The Fast Response I/O module allows the Series One Junior to respond quickly to an input and/or monitor very short input pulses. The module's four 24 V dc inputs and two relay outputs use 8 I/O references to interface with user logic. Each of the 2 outputs can operate in a manual or fast response mode. An output in manual mode is controlled from user logic similar to any other discrete output. An output in the fast response mode can be controlled independent of CPU scan time by its 2 associated inputs, with one input enabling it, and the other disabling it. Up to 5 Fast Response I/O modules can be included in a Series One Junior PC system when installed in an expansion rack, thereby providing 10 fast response outputs and 20 inputs total. Following are specifications for each of the input and output circuits.

DC INPUT CIRCUITS

Number of Circuits	4
Maximum Voltage (Open Circuit)	36 V dc
Input Current	16 mA (maximum)
ON Level	0-3 V dc
OFF Level	18-36 V dc
OFF to ON Response	0.3-1 ms
ON to OFF Response	50-150 ms
Maximum OFF Current	3 mA
Minimum ON Current	7 mA
Input Pulse Width	1 ms (minimum)
Circuit Indicator	Field Side

NOTE

Input Switching Voltage Provided by Module

RELAY OUTPUT CIRCUITS

Number of Circuits	2
Operating Voltage	5-265 V ac/dc
Ac Frequency Range	47-63 Hz
Maximum Current*	4 amp (resistive) 0.5 amp (inductive)
Maximum Leakage Current	1 mA
Smallest Recommended Load	10 mA
Maximum Inrush	5 amps
OFF To ON Response	5 ms (maximum)
ON To OFF Response	5-10 ms
Circuit Indicator	Field Side
Circuit Indicator	Field Side
Fuse (In Output Common Line)	3 amp
Internal Power Consumption	50 ma + 53 mA/Output ON Circuit at 9 V dc, 15 mA/Input @ 24 V dc

*Since non-solid state relays are used as the power switching devices, the limitations as shown in Table 6.4 must be observed for reliable operation.

Table 6.4 MAXIMUM CURRENT VS. LOAD TYPE FOR RELAY OUTPUTS

OPERATING VOLTAGE	MAXIMUM CURRENT FOR LOAD TYPE			TYPICAL LIFE (OPERATIONS)
	RESISTIVE	LAMP	SOLENOID	
220 V ac	4 Amp	0.5 Amp	0.5 Amp	100,000
220 V ac	0.05 Amp	0.05 Amp		800,000
110 V ac	4 Amp	0.5 Amp	0.5 Amp	150,000
110 V ac	0.1 Amp	0.1 Amp		650,000
24 V dc	5 Amp	0.5 Amp	0.5 Amp	100,000
50 V dc	1 Amp	0.1 Amp	0.1 Amp	100,000
100 V dc	0.5 Amp	.05 Amp	.05 Amp	100,000
250 V dc	0.3 Amp	.03 Amp	.03 Amp	100,000

NOTE

Lamp loads are defined as a X10 inrush with a power factor (PF) of 1.00 and when turned OFF represent a PF of 1.00. Solenoids are defined with a X10 inrush, a PF of 0.65, and when turned OFF represent a PF of 0.35.

The following logic diagram summarizes the operation of this module.

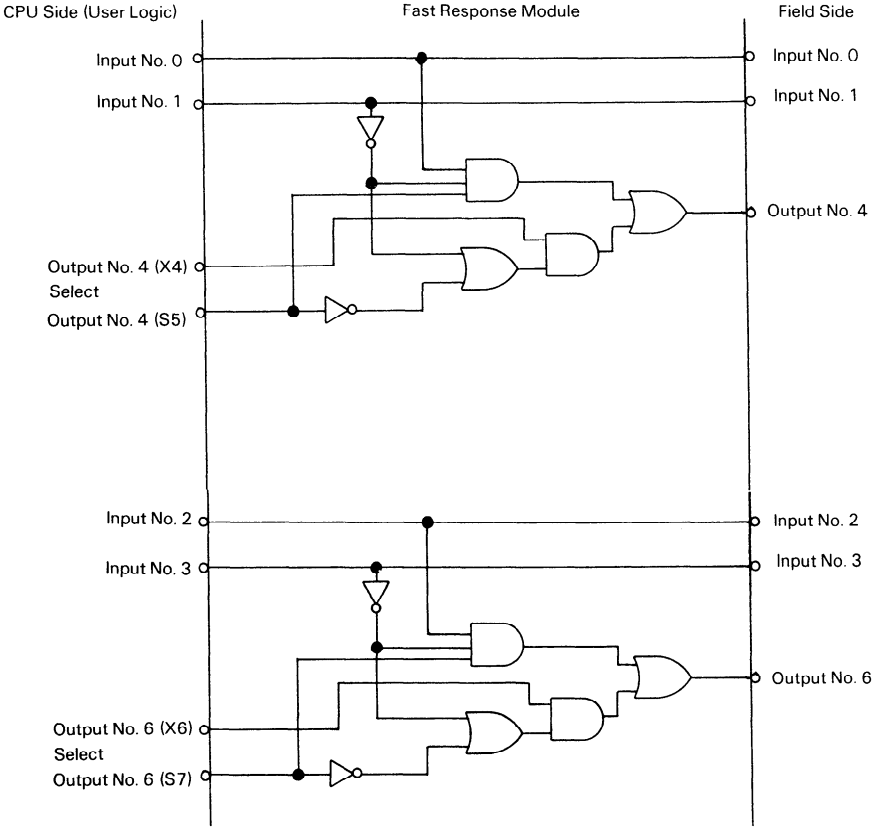

Figure 6.37 FAST RESPONSE MODULE LOGIC DIAGRAM

MODE SELECTION

The Operating Mode Selection of outputs X4 and X6 is determined by the status of their mode select references S5 and S7 as shown below.

MODE SELECT	OUTPUT
(S5 and S7)	(X4 and X6)
Disabled (0)	Manual Mode
Enabled (1)	Fast Response Mode

OUTPUT LOGIC — MANUAL MODE

An output operating in the manual mode is controlled through user logic similar to any other discrete output. Its associated inputs on the fast response module do not affect it any way.

OUTPUT LOGIC — FAST RESPONSE MODE

In the fast response mode of operation, a combination of three factors determines the status of the output.

- State of Associated Enable Input (Reference number 0 or 2)
- State of Associated Disable Input (Reference number 1 or 3)
- User Logic

The truth table (Table 6.5) shows how the output can be controlled from user logic or with its enable and disable inputs.

Table 6.5 TRUTH TABLE FOR OUTPUT IN FAST RESPONSE MODE (S5 OR S7 HAVE BEEN ENABLED)

ENABLE INPUT No. 0 or 2	DISABLE INPUT No. 1 or 3	USER LOGIC	OUTPUT X4 or X6
1	0	0	1
0	0	1	1
1	0	1	1
1	1	1	0
1	1	0	0
0	1	0	0
0	0	0	0

0: Disabled
1: Enabled

It can be seen from the first three rows in the truth table that the output can be enabled from its enable input or from user logic. The last four rows of this truth table show the various conditions that disable the outputs.

MODULE REFERENCE NUMBER	USER LOGIC SYMBOL	DESCRIPTION
0		<p>ENABLE NO. 4 OUTPUT X4 IN MANUAL MODE: OPERATES AS NORMAL DISCRETE INPUT OUTPUT X4 IN FAST RESPONSE MODE: ENABLES OUTPUT NO. 4 (X4)</p>
1		<p>DISABLE NO. 4 OUTPUT X4 IN MANUAL MODE: OPERATES AS NORMAL DISCRETE INPUT OUTPUT X4 IN FAST RESPONSE MODE: DISABLES OUTPUT NO. 4 (X4)</p>
2		<p>ENABLE NO. 6 OUTPUT X6 IN MANUAL MODE: OPERATES AS NORMAL DISCRETE INPUT OUTPUT X6 IN FAST RESPONSE MODE: ENABLES OUTPUT NO. 6 (X6)</p>
3		<p>DISABLE NO. 6 OUTPUT X6 IN MANUAL MODE: OPERATES AS NORMAL DISCRETE INPUT OUTPUT X6 IN FAST RESPONSE MODE: DISABLES OUTPUT NO. 6 (X6)</p>
X4		<p>OUTPUT NO. 4 IN MANUAL MODE: OPERATES AS NORMAL DISCRETE OUTPUT IN FAST RESPONSE MODE: CAN BE CONTROLLED FROM USER LOGIC OR BY INPUTS NO. 0 AND NO. 1</p>
S5		<p>MODE SELECT NO. 4 IF DISABLED: PUTS OUTPUT NO. 4 (X4) IN MANUAL MODE IF ENABLED: PUTS OUTPUT NO. 4 (X4) IN FAST RESPONSE MODE</p>
X6		<p>OUTPUT NO. 6 IN MANUAL MODE: OPERATES AS NORMAL DISCRETE OUTPUT IN FAST RESPONSE MODE: CAN BE CONTROLLED FROM USER LOGIC OR BY INPUTS NO. 2 AND NO. 3</p>
S7		<p>MODE SELECT NO. 6 IF DISABLED: PUTS OUTPUT NO. 6 (X6) IN MANUAL MODE IF ENABLED: PUTS OUTPUT NO. 6 (X6) IN FAST RESPONSE MODE</p>

Figure 6.38 MODULE REFERENCE NUMBER/LOGIC SYMBOL DEFINITION

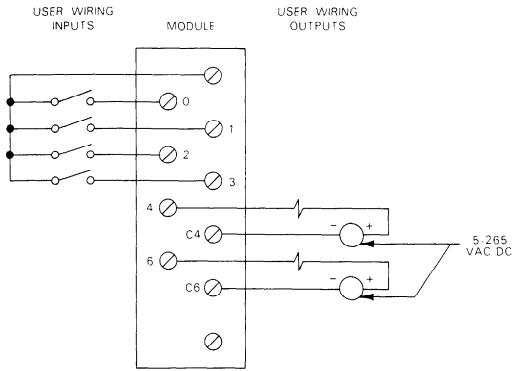

USER WIRING DIAGRAM

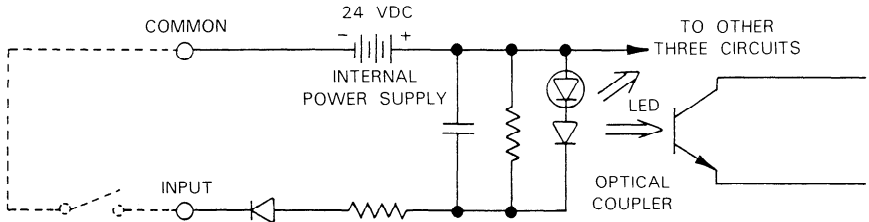

SAMPLE INPUT CIRCUIT

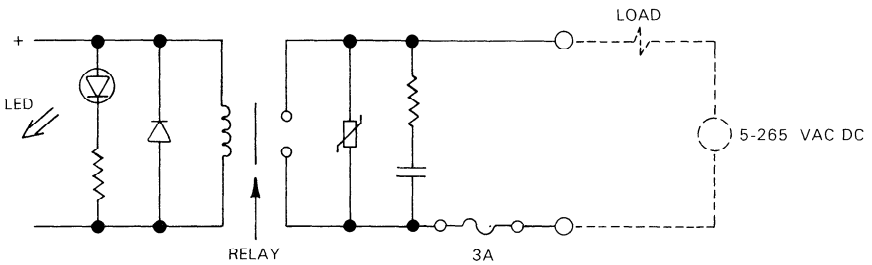

SAMPLE OUTPUT CIRCUIT

Figure 6.39 WIRING FOR FAST RESPONSE I/O MODULE

PC-S1-84-0020
 PC-S1-84-0016
 PC-S1-84-0015

**I/O SIMULATOR
IC610MDL124**

The I/O simulator module has 8 two-position (ON or OFF) switches, each having an associated LED, that is, if switch 1 is turned ON, LED 1 will light. An I/O simulator module uses one I/O slot and the 8 I/O references assigned to that slot. Each of the switches can be programmed as a discrete input device. This module requires no field connections since its function is controlled by programming. An I/O simulator module is a valuable tool in program development and troubleshooting. An I/O simulator could also be programmed to be used as conditional input contacts for control of output devices. Specifications for this module are as follows:

ON to OFF Response	4-15 ms
OFF to ON Response	4-15 ms
Internal Power Consumption	10 mA @ 9 V dc 14 mA/Circuit ON @ 24 V dc
Units of Load	1 unit @ 9 V dc 11 units @ 24 V dc
Weight	3.2 oz (90 g)

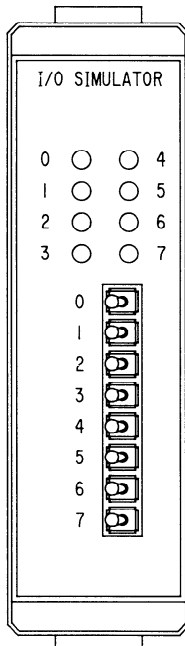

Figure 6.40 I/O SIMULATOR MODULE FACEPLATE

**I/O EXPANSION UNIT
24 V dc SINK INPUT/OUTPUT
IC609EXP110**

This expansion unit provides 16 dc sink input and 10 dc sink output circuits and when used with a basic Series One Junior PC provides a total of 50 I/O points for a Series One Junior PC system. Each of the 16 input circuits is designed to receive a single discrete (ON/OFF) signal from user supplied devices, such as pushbuttons, limit switches and relay contacts. The 10 output circuits are each capable of controlling user supplied discrete (ON/OFF) loads. These loads typically are devices such as relay coils, motor starters, and indicator lights. Output circuits are arranged in 2 groups, with 4 circuits in the C1 group and 6 circuits in the C2 group. Each of the 2 groups is protected by a 5 amp fuse. The ON or OFF state of each circuit is indicated by an LED (one per circuit) located under the appropriate circuit number on the lens. Following are specifications for each of the input and output circuits.

DC SINK INPUT CIRCUITS (30 to 47)

Input Points	16
Open Circuit Voltage of Input (no load)	24 V dc
Maximum Input Current	12 mA (each circuit)
ON Current	>6 mA
OFF Current	<3 mA
ON Voltage	<7 V dc
OFF Voltage	>18 V dc
OFF to ON Response	5 to 10 ms
ON to OFF Response	5 to 10 ms

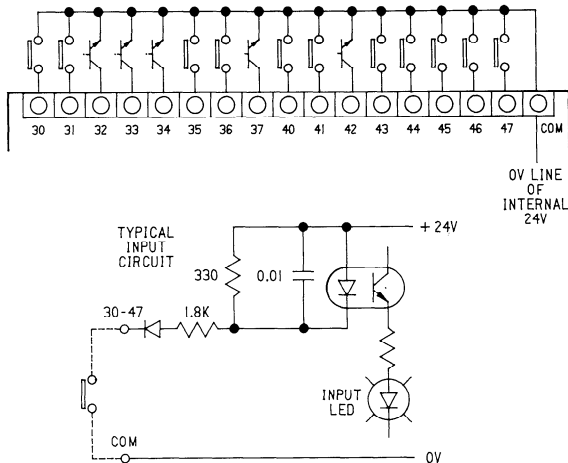
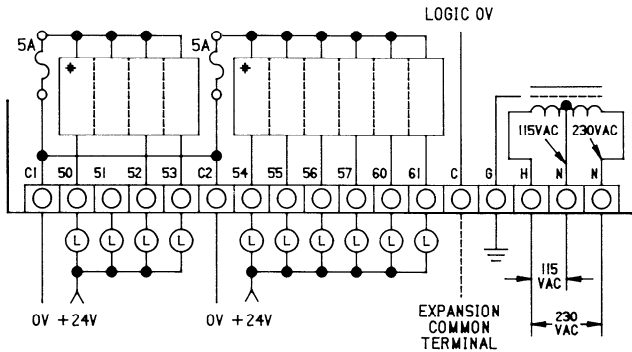

Figure 6.41 FIELD WIRING INFORMATION AND TYPICAL INPUT CIRCUIT FOR 24 V dc SINK INPUTS

DC SINK OUTPUT CIRCUITS (50 to 61)

Output Points	10
Output Circuit	NPN — Open Collector
Operating Voltage	5 to 24 V dc
Peak Voltage	45 V dc (Maximum)
Maximum Switching Current	0.5 A (Individual) Total (1A-C1 Group, 1.5 A-C2 Group)
Maximum Leakage Current	<100 μ A
Voltage Drop	>1.5 V dc (0.5 A)
OFF to ON Response	0.1 ms
ON to OFF Response	0.1 ms
Fuses (2, Internal)	5A, Fast Blow for C1 and C2 Group



CAUTION

***DO NOT CONNECT THIS TERMINAL (230 V AC N) UNLESS USING 230 V AC AS THE POWER SOURCE, OTHERWISE DAMAGE TO THE UNIT MAY OCCUR.**

NOTE :

- ⊙ = TYPICAL LOAD
- N = NEUTRAL
- H = HOT
- ⊕ = TYPICAL DC OUTPUT CIRCUIT

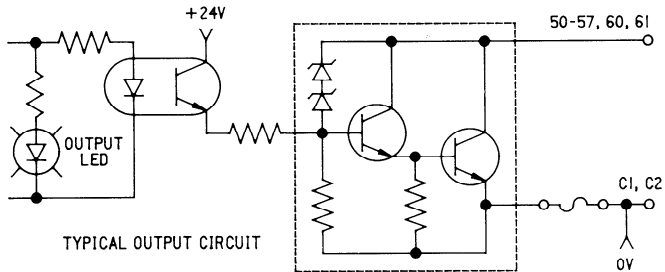

Figure 6.42 FIELD WIRING INFORMATION AND TYPICAL OUTPUT CIRCUIT FOR 24 V dc SINK OUTPUTS

**I/O EXPANSION UNIT
24 V dc SINK INPUT/RELAY OUTPUT
IC609EXP120**

This expansion unit provides 16 dc sink input and 10 relay output circuits and when used with a basic Series One Junior PC provides a total of 50 I/O points for a Series One Junior PC system. Each of the 16 input circuits are designed to receive a single discrete (ON/OFF) signal from user supplied devices, such as pushbuttons, limit switches and relay contacts. The 10 relay output circuits are each capable of controlling user supplied discrete (ON/OFF) loads. These loads typically are devices such as relay coils, motor starters, and indicator lights. Since the relay output circuits were not designed for a specific voltage, such as 24 V dc or 115 V ac, they can be used to control a wide variety of loads and signal types. The output circuits are arranged in 2 groups, with 4 circuits in the C1 group and 6 circuits in the C2 group. Each group is protected by a 5 amp fuse. The ON or OFF state of each circuit is indicated by an LED (one per circuit) located under the appropriate circuit number on the lens. Following are specifications for each of the input and output circuits.

DC SINK INPUT CIRCUITS (30 to 47)

Input Points	16
Open Circuit Voltage of Input (no load)	24 V dc
Maximum Input Current	12 mA (each circuit)
ON Current	>6 mA
OFF Current	<3 mA
ON Voltage	<7 V dc
OFF Voltage	>18 V dc
OFF to ON Response	5 to 10 ms
ON to OFF Response	5 to 10 ms

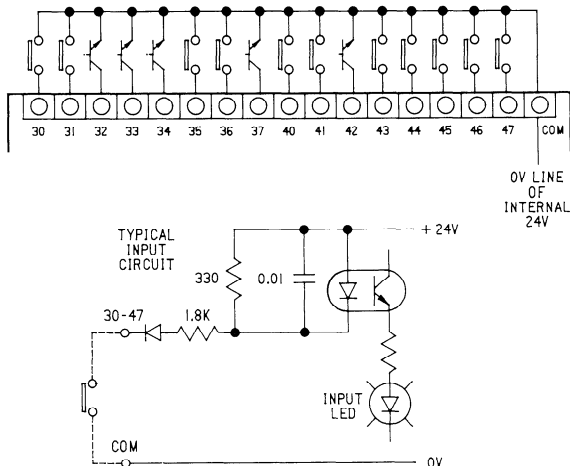

Figure 6.43 FIELD WIRING INFORMATION AND TYPICAL INPUT CIRCUIT FOR 24 V dc SINK INPUTS

RELAY OUTPUT CIRCUITS (50 to 61)

Output Points	10
Operating Voltage	5 to 265 V ac/dc
Maximum Contact Ratings	See Table Below
AC Frequency	47 to 63 Hz
Maximum Current	2 A
Maximum Inrush	See Note Below
Maximum Leakage Current	1 mA (220 V ac, 60Hz)
Smallest Recommended Load	5 mA @ 5 V
OFF to ON Response	10 ms (maximum)
ON to OFF Response	10 ms (maximum)
Fuses (2, Internal)	5A, Normal Blow for C1 Group 5A, Normal Blow for C2 Group

Table 6.6 MAXIMUM CURRENT FOR LOAD TYPES

OPERATING VOLTAGE	MAXIMUM CURRENT FOR LOAD TYPE			TYPICAL LIFE (OPERATIONS)
	RESISTIVE	LAMP	SOLENOID	
220 V ac	2 Amp	0.3 Amp	0.3 Amp	200,000
220 V ac		0.05 Amp	0.05 Amp	800,000
110 V ac		0.3 Amp	0.3 Amp	250,000
110 V ac		0.1 Amp	0.1 Amp	500,000
24 V dc	2 Amp	0.3 Amp		200,000

NOTE

Lamp loads are defined as a X10 inrush with a power factor (PF) of 1.00 and when turned OFF represent a PF of 1.00. Solenoids are defined with a X10 inrush, a PF of 0.65, and when turned OFF represent a PF of 0.35.

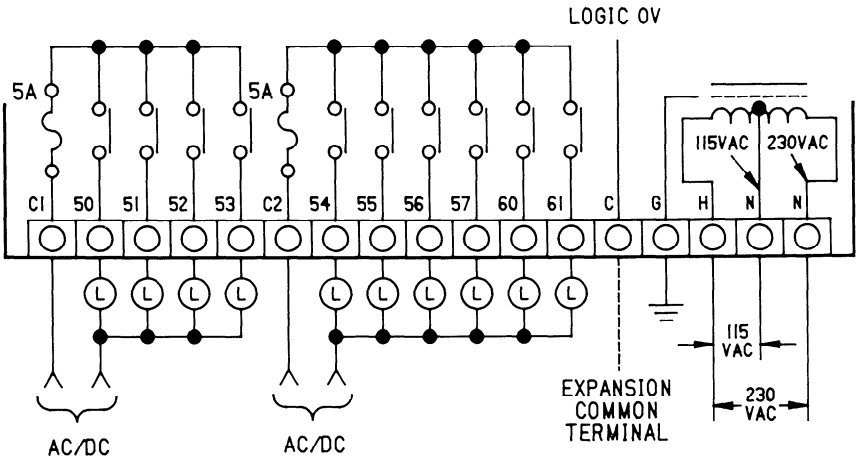

NOTE :

- ⊙ = TYPICAL LOAD
- N = NEUTRAL
- H = HOT

TYPICAL OUTPUT CIRCUIT

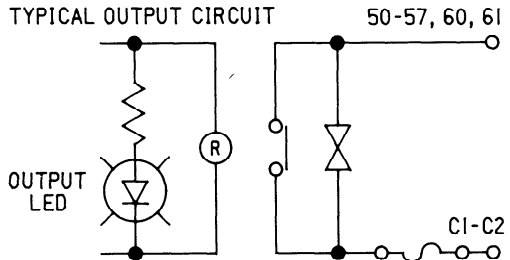

CAUTION

*** DO NOT CONNECT THIS TERMINAL (230 V AC N) UNLESS USING 230 V AC AS THE POWER SOURCE, OTHERWISE DAMAGE TO THE UNIT MAY OCCUR.**

NOTE

Since a surge-absorbing circuit is built-in, there is current leakage through the circuit. A bleeder resistor should be connected across the load to prevent incorrect operation in the event that light loads, such as small relays or neon lamps are used. Leakage may hold these devices on if a bleeder resistor is not used.

Figure 6.44 FIELD WIRING INFORMATION AND TYPICAL OUTPUT CIRCUIT FOR RELAY OUTPUTS

**I/O EXPANSION UNIT
24 V dc SOURCE INPUT/RELAY OUTPUT
IC609EXP121**

This expansion unit provides 16 dc source input and 10 relay output circuits and when used with a basic Series One Junior PC provides a total of 50 I/O points for a Series One Junior PC system. Each of the 16 source input circuits are designed to receive a single discrete (ON/OFF) signal from user supplied devices, such as pushbuttons, limit switches and relay contacts. The 10 relay output circuits are each capable of controlling user supplied discrete (ON/OFF) loads, such as motor starters and indicator lights. The 10 relay output circuits are arranged in 2 groups with 6 outputs in one group and 4 in the other. Each group is protected by a 5 amp fuse and each group can be supplied from a separate power source. Since the relay output circuits were not designed for a specific voltage, such as 24 V dc or 115 V ac, they can be used to control a wide variety of loads and signal types. The ON or OFF state of each circuit is indicated by an LED (one per circuit) located under the appropriate circuit number on the lens. Following are specifications for each of the input and output circuits.

DC SOURCE INPUT CIRCUITS (30 to 47)

Input Points	16
Open Circuit Voltage of Input (no load)	0 V dc
Maximum Input Current	13 mA (each circuit)
ON Current	>6 mA
OFF Current	<3 mA
ON Voltage	<7 V dc (between COM and Input terminal)
OFF Voltage	>18 V dc (between COM and Input terminal)
OFF to ON Response	5 to 10 ms
ON to OFF Response	5 to 10 ms

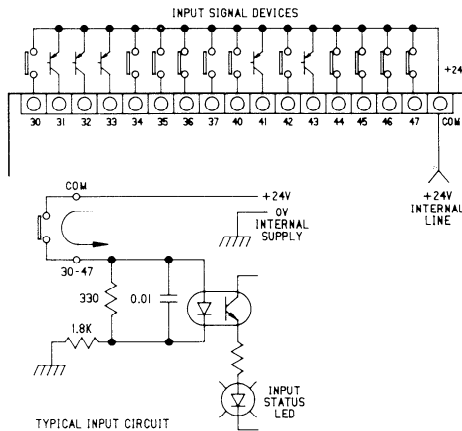

Figure 6.45 FIELD WIRING INFORMATION AND TYPICAL INPUT CIRCUIT FOR 24 V dc SOURCE INPUTS

RELAY OUTPUT CIRCUITS (50 to 61)

Output Points	10
Operating Voltage	5 to 265 V ac/dc
Maximum Contact Ratings	See Table Below
AC Frequency	47 to 63 Hz
Maximum Current	2 A
Maximum Inrush	See Note Below
Maximum Leakage Current	1 mA (220 V ac, 60Hz)
Smallest Recommended Load	5 mA @ 5 V
OFF to ON Response	10 ms (maximum)
ON to OFF Response	10 ms (maximum)
Fuses (2, Internal)	5A, Normal Blow for C1 and C2 Group

Table 6.7 MAXIMUM CURRENT FOR LOAD TYPES

OPERATING VOLTAGE	MAXIMUM CURRENT FOR LOAD TYPE			TYPICAL LIFE (OPERATIONS)
	RESISTIVE	LAMP	SOLENOID	
220 V ac	2 Amp	0.3 Amp	0.3 Amp	200,000
220 V ac		0.05 Amp	0.05 Amp	800,000
110 V ac		0.3 Amp	0.3 Amp	250,000
110 V ac	2 Amp	0.1 Amp	0.1 Amp	500,000
24 V dc		0.3 Amp		200,000

NOTE

Lamp loads are defined as a X10 inrush with a power factor (PF) of 1.00 and when turned OFF represent a PF of 1.00. Solenoids are defined with a X10 inrush, a PF of 0.65, and when turned OFF represent a PF of 0.35.

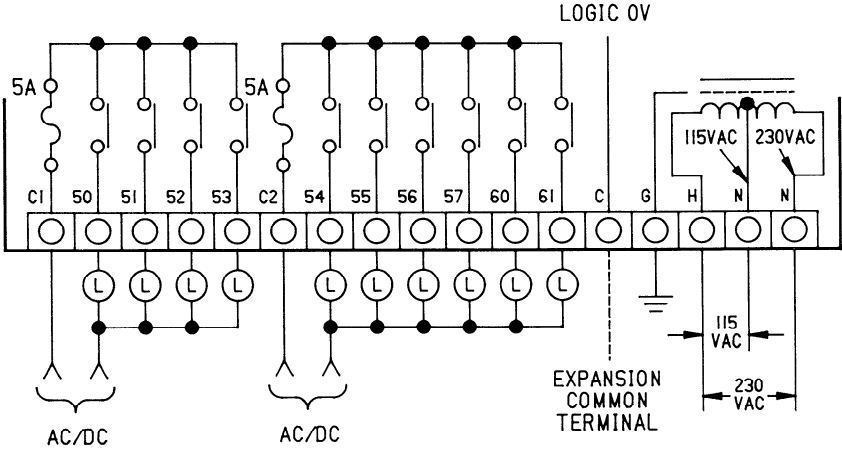

NOTE:

- (L) = TYPICAL LOAD
- N = NEUTRAL
- H = HOT

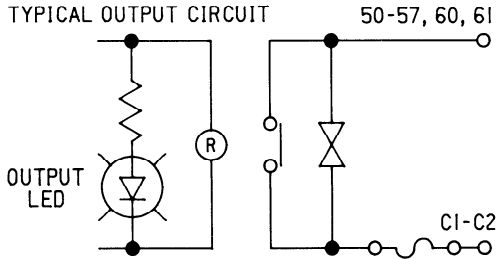

CAUTION

*** DO NOT CONNECT THIS TERMINAL (230 V AC N) UNLESS USING 230 V AC AS THE POWER SOURCE, OTHERWISE DAMAGE TO THE UNIT MAY OCCUR.**

Figure 6.46 FIELD WIRING INFORMATION AND TYPICAL OUTPUT CIRCUIT FOR RELAY OUTPUTS

ANALOG INPUT MODULE IC610MDL116

INTRODUCTION

The Analog Input module provides four independent input channels capable of converting an analog input signal to a digital signal for processing by the programmable controller. This module can be used with any of the Series One family of programmable controllers. However, the input can only be provided in binary form with a Series One or Series One Junior. Only one Analog Input or one Analog Output module can be used with a Series One Junior PC. That module must be placed in the 5 or 10-slot expansion rack. *Note that only the first slot, which is next to the I/O expansion module, in the Series One Junior expansion rack can contain a high density module.* The Series One Plus, in addition to the basic functions, provides data operations (including math functions), which allows other types of operations to be performed when using the analog input module. Each Analog Input module requires 16 I/O references for addressing.

Although this module can be used with the Series One and Series One Junior, in addition to the Series One Plus, certain programming techniques will make better use of the capabilities of the Analog Input module with these PC's. An APPLICATION NOTE will be issued explaining those techniques in detail.

HARDWARE FEATURES

The user can select, by jumper placement, to use either voltage inputs (1 to 5 V dc) or current inputs (4 to 20 mA). The factory setting is for voltage input operation. Resolution is 8 bits, which allows a maximum digital value of 255 to be converted. Eight LEDs on the faceplate provide an 8-bit binary display of the input. The channel to be displayed is selected by depressing a pushbutton on the faceplate. Each time the pushbutton is depressed, the next channel in sequence is selected, i.e. channel 1, 2, 3, 4, 1, etc.

User field wiring is made to a removable terminal board on the module's faceplate. A hinged plastic terminal cover on the terminal board protects the terminals. The terminal cover has a removable label that can be used to record circuit information.

The maximum conversion time is 2 milliseconds and does not add to the scan time of the CPU. The four channels are converted one at a time, with one channel being converted each scan. Each successive scan converts the next channel in turn.

POWER REQUIREMENTS

This module requires an external 24 V dc power supply. The 24 V dc supply in Series One racks can be used, however the current provided by the rack is limited to 100 mA, which is sufficient current for one Analog Input module, since the module requires up to 65 mA for operation.

GENERAL AND ELECTRICAL SPECIFICATIONS

Specifications for this module are provided in the following table.

Table 6.8 ANALOG INPUT MODULE SPECIFICATIONS

Number of Channels	4 (Independent)
Input Ranges	+1 to +5 V dc or 4 to 20 mA (jumper selectable for each channel)
Resolution	8-bit binary (1 in 256)
Digital Outputs	8 bits, binary data output 4 bits, channel status
I/O Points Required	16 consecutive (per slot assignments for 16 points, 30 to 37 and 130 to 137, etc.)
LED Display (16 LEDs)	8 bits: Data being read into the selected channel 4 bits: Channel selected for Data Display 4 bits: Channels being scanned
Operating Temperature	0° to 60°C (32° to 140°F)
Relative Humidity	5% to 95% (non-condensing)
Input Types	Differential
Input Impedance	≥1 MΩ (Voltage Input) 250 Ω (Current Input)
Absolute maximum Ratings	Voltage Input, 0 to +10 V dc Current Input, 0 to 30 mA
Conversion Method	Successive Approximation Method
Conversion Time	2 msec, maximum
Linearity Error	±0.8%, maximum
Accuracy	±1% at 25°C, maximum
Accuracy vs. Temperature	±50 ppm (parts per million) per 1°C
External Power Source	+24 V dc, 65 mA (maximum)
9 V dc Power Consumption	55 mA (Supplied by rack power supply)

I/O REFERENCE DEFINITIONS

The Analog Input module uses 16 consecutive I/O points, beginning with the first I/O reference assigned to the I/O slot selected for the module. In the table, it is assumed that the Analog Input module is placed in slot 1 of a properly configured 5 or 10-slot rack (references 30 to 37 and 130 to 137). *These references are used for Series One Junior, for other valid references for I/O slots that allow 16 references, refer to the Series One and Series One Plus User's Manual.* The following table defines the use of each of the I/O points.

Table 6.9 I/O POINT DEFINITION

I/O POINT	DEFINITION	WEIGHT	I/O TYPE
30	Data Bit - Binary	1	Input
31	Data Bit - Binary	2	Input
32	Data Bit - Binary	4	Input
33	Data Bit - Binary	8	Input
34	Data Bit - Binary	16	Input
35	Data Bit - Binary	32	Input
36	Data Bit - Binary	64	Input
37	Data Bit - Binary	128	Input
130	Channel 1 This bit is used in ladder logic to sense when the data received at the inputs is for this channel.		Input
131	Channel 2 Sense bit		Input
132	Channel 3 Sense bit		Input
133	Channel 4 Sense bit		Input
134	This output combined with the following output can be set to selectively scan only 1 channel, instead of all 4. These outputs are ignored if the scan selection output is on. The desired channel is selected by setting these two outputs in the ladder logic to the state as shown below, for that channel.		Output
135			
	OUTPUT 134	OUTPUT 135	CHANNEL
	0	0	1
	1	0	2
	0	1	3
	1	1	4
136	Not used		
137	Scan selection output. This bit must be set for the module to read data input, unless the selected channel scan outputs are used. This output is set in the ladder logic program.		Output

SAMPLE LADDER LOGIC FOR CHANNEL SELECTION

Sample ladder diagrams are provided below using the same I/O referencing as is used in defining the I/O points in Table 6.9 on the previous page. These are examples of programming the Series One Junior.

- **Example 1.** If all 4 channels are to be scanned, output 137 must be on.

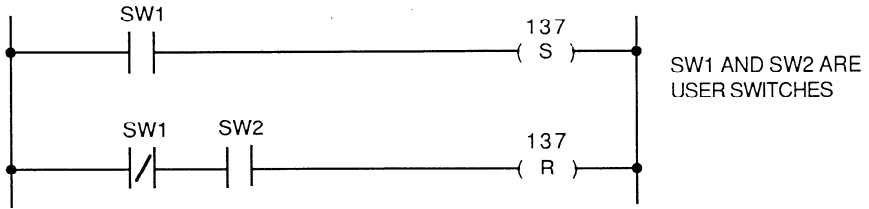

- **Example 2.** This example of ladder logic allows you to select the channel to be scanned.

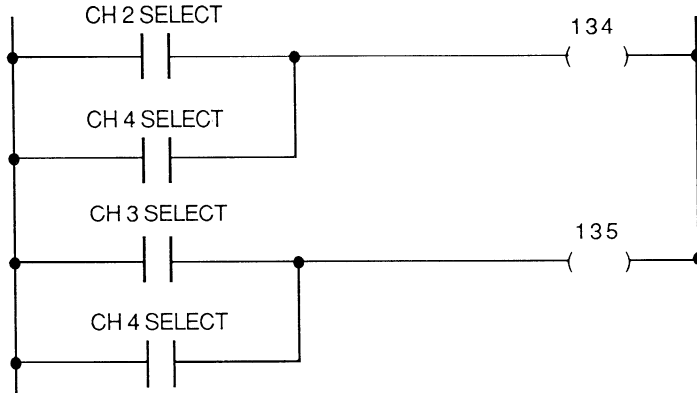

ANALOG INPUT MODULE FEATURES

The following figure is an illustration of the faceplate for the Analog Input module, showing its features and user wiring connections.

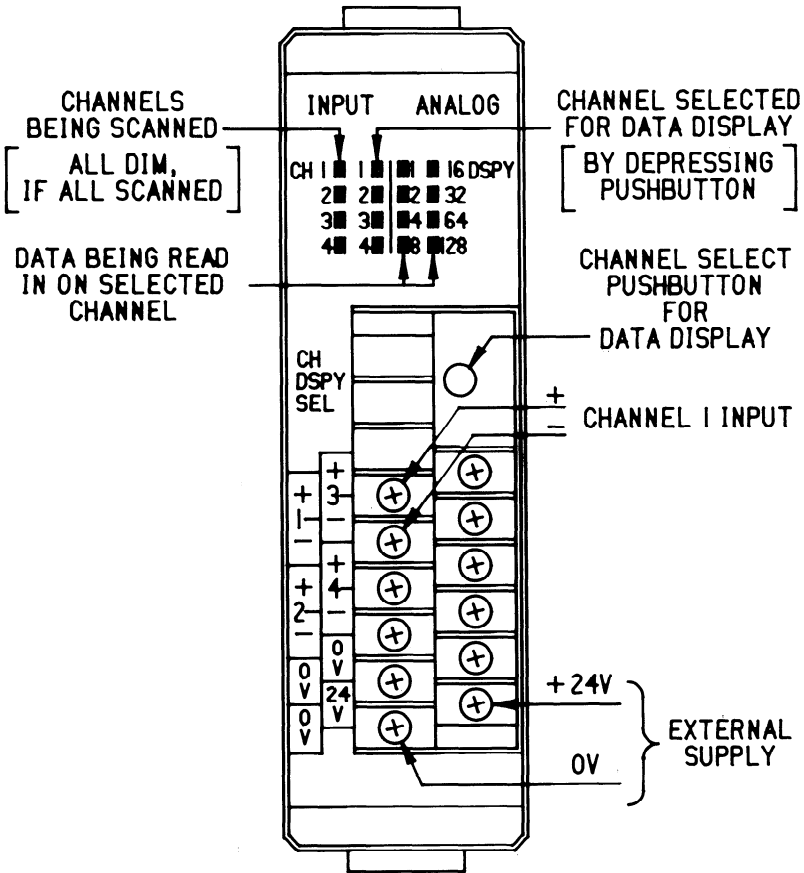

Figure 6.47 ANALOG INPUT MODULE FACEPLATE

SELECTION OF OPERATING MODE

The mode of operation, either 1 to 5 V or 4 to 20 mA is determined by the absence or presence of jumper plugs on pins that are located on the side of the bottom circuit board. There are four sets of pins (2 pins in each set), with one set for each channel. The first set of pins is labeled **CH1** and the last set of pins is labeled **CH4**. The factory default setting is for 1 to 5 V operation, which is no jumper present. To select the 4 to 20 mA mode of operation for any channel, place a jumper on the two pins for the channel or channels and push the jumper firmly onto the pins.

ANALOG OUTPUT MODULE IC610MDL166

INTRODUCTION

The Analog Output module provides two independent output channels, each capable of converting 8 bits of binary data to an analog output. This module can be used with any of the Series One family of programmable controllers. The Series One Plus, in addition to the basic functions, provides data operations (including math functions), which allows other types of operations to be performed when using the analog output module. Each Analog Output module requires 16 I/O references for addressing.

Although this module can be used with the Series One and Series One Junior, in addition to the Series One Plus, certain programming techniques will make better use of the capabilities of the Analog Output module with these PC's. An APPLICATION NOTE will be issued explaining those techniques in detail.

HARDWARE FEATURES

Each channel can provide either a voltage output (0 to +10 V dc) or current output (4 to 20 mA, source). Voltage or current selection for each channel is user selected by how the field wiring is connected on the screw terminals on the faceplate. Resolution is 8 bits, which allows a maximum digital value of 255 to be converted. Eight LEDs for each channel on the faceplate provide an 8-bit binary display of the data output for each channel.

User field wiring is made to a removable terminal board on the module's faceplate. A hinged plastic terminal cover on the terminal board protects the terminals. The terminal cover has a removable label that can be used to record circuit information.

The maximum conversion time is 10 microseconds and does not add to the scan time of the CPU. Both channels are converted with each scan.

POWER REQUIREMENTS

This module requires an external 24 V dc power supply. The 24 V dc supply in Series One racks can be used, however the current provided by the rack is 100 mA, which is sufficient current for *one* Analog Output channel, since the module requires up to 85 mA for operation. The maximum load for both channels is 170 mA.

GENERAL AND ELECTRICAL SPECIFICATIONS

Specifications for this module are provided in the following table.

Table 6.10 ANALOG OUTPUT MODULE SPECIFICATIONS

Number of Channels	2 (Independent)
Analog Output Ranges	0 to + 10 V dc or 4 to 20 mA (selectable for each channel on faceplate terminals)
Resolution	8-bit binary (1 in 256)
Digital input Data	8 bits, binary from the CPU
I/O Points Required	16 consecutive (per slot assignments for 16 points, 30 to 37 and 130 to 137, etc.)
LED Display (16 LEDs) 8 LEDs for each channel	8 bit binary data display of output data for each channel
Operating Temperature	0° to 60°C (32° to 140°F)
Relative Humidity	5% to 95% (non-condensing)
Output Impedance	≤0.5Ω (Voltage Output)
Output Current	10 mA, maximum (Voltage Output)
External Resistor	550Ω, maximum (Current Output)
Conversion Start	At start of CPU's scan
Conversion Time	10 msec, maximum
Accuracy	± 0.2% at 25°C
Accuracy vs. Temperature	± 30 ppm (parts per million) per 1°C
External Power Source	+ 24 V dc, 85 mA (maximum)
9 V dc Power Consumption	55 mA (Supplied by rack power supply)

I/O REFERENCE DEFINITIONS

The Analog Output module uses 16 consecutive I/O points, beginning with the first I/O reference assigned to the I/O slot selected for the module. In the table, it is assumed that the Analog Output module is placed in slot 1 of a properly configured 5 or 10-slot rack (references 30 to 37 and 130 to 137). *These references are used for the example only, for other valid references for I/O slots that allow 16 references, refer to the Series One and Series One Plus User's Manual.* The following table defines the use of each of the I/O points.

Table 6.11 I/O POINT DEFINITION

I/O POINT	DEFINITION	I/O TYPE
	CHANNEL DATA WEIGHT	
30	Channel 1 - Data Bit 1	Output
31	Channel 1 - Data Bit 2	Output
32	Channel 1 - Data Bit 3	Output
33	Channel 1 - Data Bit 4	Output
34	Channel 1 - Data Bit 5	Output
35	Channel 1 - Data Bit 6	Output
36	Channel 1 - Data Bit 7	Output
37	Channel 1 - Data Bit 8	Output
130	Channel 2 - Data Bit 1	Output
131	Channel 2 - Data Bit 2	Output
132	Channel 2 - Data Bit 3	Output
133	Channel 2 - Data Bit 4	Output
134	Channel 2 - Data Bit 5	Output
135	Channel 2 - Data Bit 6	Output
136	Channel 2 - Data Bit 7	Output
137	Channel 2 - Data Bit 8	Output

ANALOG OUTPUT MODULE FEATURES

The following figure is an illustration of the faceplate for the Analog Output module, showing its features and user wiring connections.

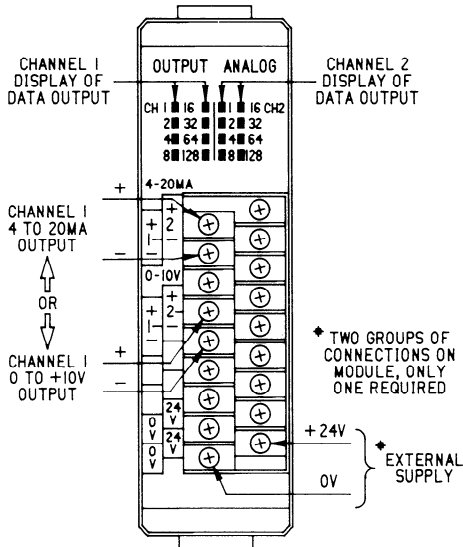

Figure 6.48 ANALOG OUTPUT MODULE FACEPLATE

UL LISTED PRODUCTS

The Series One Junior and Series One products that have obtained UL approval or are UL pending are described in this section. These products are listed below. As with all products that have obtained UL approval, each listed item has an attached UL label.

- IC609SJR101 Series One Junior basic unit, 115 V ac Input - 115 V ac Output with 12 ac and 2 dc Input (or high speed counter) circuits and 9 ac Output circuits.
- IC609EXP101 Series One Junior expansion unit, 115 V ac Input - 115 V ac Output with 13 ac Input circuits and 9 ac Output circuits.
- IC610CPU101 Series One CPU. Version C of the CPU is UL listed. The functionality of the CPU has not changed, all specifications are the same as the previous version.
- IC610CHS111 Series One 5-slot rack. 115 V ac source of input power required.
- IC610MDL135 Series One 115 V ac Input module, 6 circuits.
- IC610MDL181 Series One Relay Output module, 5 circuits.
- IC610MDL185 Series One 115 V ac Output module, 6 circuits.

The following pages contain the technical information required to implement the UL listed Series One Junior basic and expansion units and the Series One UL listed I/O modules.

**SERIES ONE JUNIOR UL LISTED BASIC UNIT
115 V ac INPUT - 115 V ac OUTPUT
IC609SJR101**

This UL listed basic unit provides 12 ac and 2 dc input circuits and nine ac output circuits. The input circuits are each designed to receive a single discrete (ON/OFF) signal from user supplied devices such as limit switches, pushbuttons, selector switches, and relay contacts. Circuits 15 and 16 can be used for high speed count input and reset or used as normal dc sink input points.

The 9 ac output circuits are each capable of controlling user supplied discrete (ON/OFF) loads. Typical loads include relay coils, motor starters, solenoid valves, and indicator lights. The ac output circuits were designed to be used for 115 V ac loads. The ON/OFF state of each input and output circuit is indicated by an LED. The LEDs are located beneath the red lens on the unit. Operating voltage for this unit is 115 V ac only. This unit does not accept 230 V ac, as does the comparable non UL unit (IC609SJR100). Figures 6.49 and 6.50 provide wiring information for this unit. Specifications for this basic unit are listed below.

Operating Voltage	97 to 126 V ac
AC Frequency	47 to 63 Hz
Maximum Load	25 VA

AC INPUT CIRCUITS (0 to 13)

Input Points	12
Operating Voltage	97 to 132 V ac
AC Frequency	47 to 63 Hz
Input Current (nominal)	10 mA per Point
Input Impedance	11 K ohms
ON Level	>80 V ac
OFF Level	<20 V ac
OFF to ON/ON to OFF Response	10 to 30 ms
Circuit Indicator	Logic Side

DC (HIGH SPEED COUNTER) INPUT CIRCUITS (15, 16)

Input Points	2
Input Device	Input 15 must use an open collector device
Maximum Voltage on Input Terminal (no load)	26 V dc
Open Circuit Voltage of Input (nominal)	24 V dc
Input Current	12 mA (maximum)
Input Impedance	1.8 K ohms
ON Level	0 to 7 V dc
OFF Level	18 to 26 V dc
OFF to ON/ON to OFF Response	0.1 ms
Circuit Indicator	Logic Side
Maximum OFF Leakage	3 mA
Minimum ON Current	6 mA

NOTE

* Input 15 must be driven by an open collector device when being used as a high speed counter input. If a normal switch contact were used, switch bounce could cause multiple incorrect input pulses to be counted.

Counter input circuits are dc inputs. Terminals No. 15 and 16 can be used as normal dc sink inputs when not being used as high speed counter inputs.

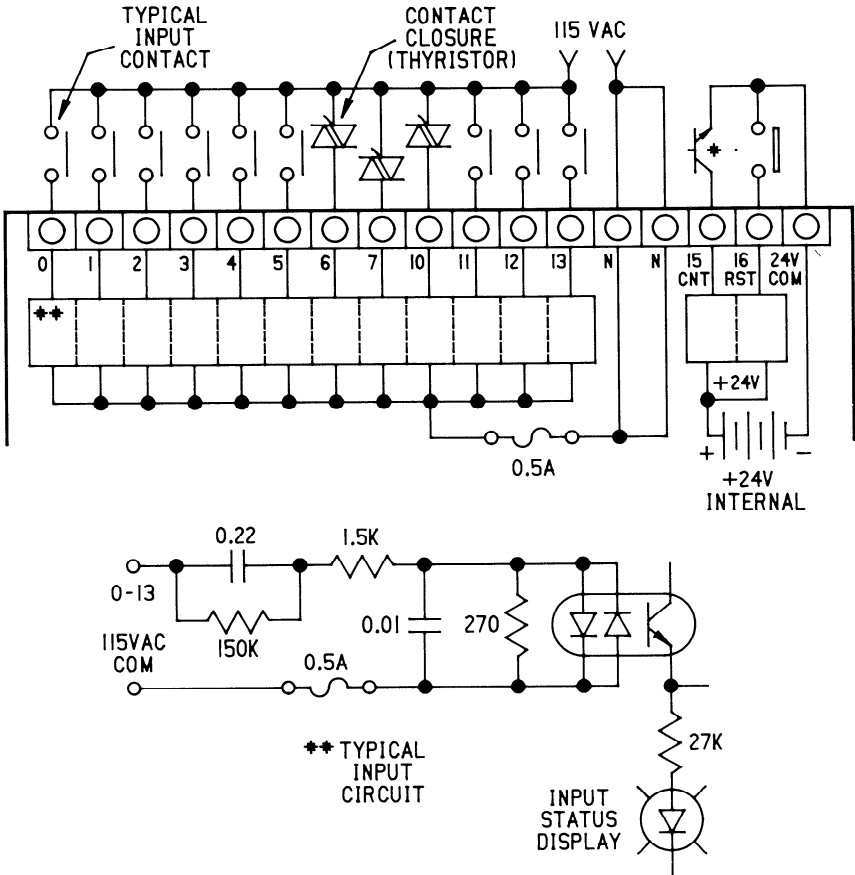

Figure 6.49 WIRING FOR 115 V ac INPUTS FOR UL LISTED BASIC UNIT

AC OUTPUT CIRCUITS (17, 20 to 27)

Output Points	9
Operating Voltage (User Loads)	97 to 132 V ac
AC Frequency	47 to 63 Hz
Maximum Current	1 A Continuous
Maximum Inrush	10 amps for 8 ms 5 amps for 100 ms
Maximum Leakage Current	3.5 mA at 115 V, 60 Hz
ON Voltage Drop	1.6 V at 1 amp 1.6 V at 0.5 amp
Smallest Recommended Load	25 mA
OFF to ON Response	1 ms
ON to OFF Response	8 to 10 ms (1/2 cycle)
Circuit Indicator	Logic Side

MAXIMUM LOAD CURRENT INFORMATION

The maximum load current for this module is dependent on ambient temperature. This is shown in the following chart. This information is also applicable for the UL listed expansion unit, IC609EXP101. This information can also be found on the faceplate of each of the Series One Junior UL listed units.

MAXIMUM QUANTITY OF OUTPUT ON CIRCUITS

Temperature (°C) at Vents Inlet	Each at 1 Amp	Each at 0.5 Amp
25°C	9	9
40°C	6	9
50°C	4	8
55°C	3	8
60°C	2	7

NOTE

Since a surge-absorbing circuit is built-in, there is current leakage through the circuit. A bleeder resistor should be connected across the load to prevent incorrect operation in the event that light loads, such as small relays or neon lamps, are used. Leakage may hold these devices on if a bleeder resistor is not used.

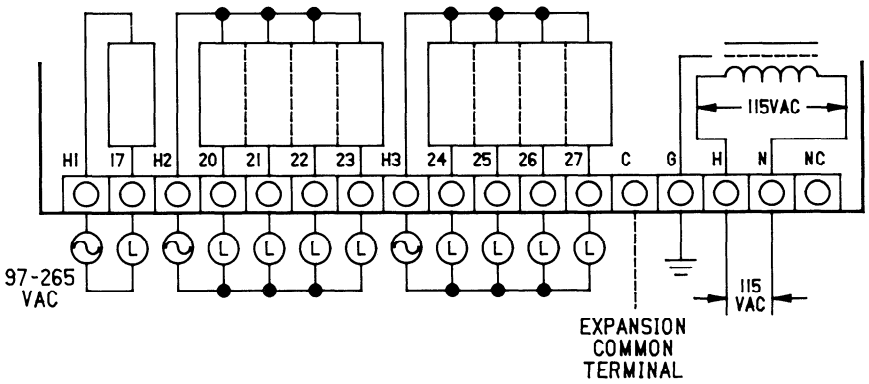

NOTE:

- (L) = TYPICAL LOAD
- N = NEUTRAL
- H = HOT

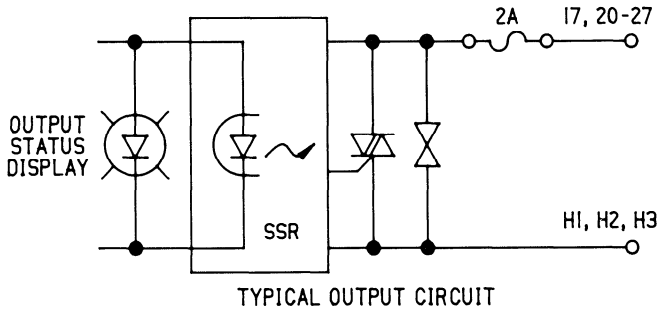

Figure 6.50 WIRING FOR 115 V ac OUTPUTS FOR UL LISTED BASIC UNIT
 TPK.A.41695

SERIES ONE JUNIOR UL LISTED EXPANSION UNIT
115 V ac INPUT - 115 V ac OUTPUT
IC609EXP101

The UL listed expansion unit provides 13 ac input circuits and nine ac output circuits. The input circuits are each designed to receive a single discrete (ON/OFF) signal from user supplied devices such as limit switches, pushbuttons, selector switches, and relay contacts.

The 9 ac output circuits are each capable of controlling user supplied discrete (ON/OFF) loads. Typical loads include relay coils, motor starters, solenoid valves, and indicator lights. The ac output circuits were designed to be used for 115 V ac loads. The ON/OFF state of each input and output circuit is indicated by an LED viewed beneath the red lens on the unit.

Operating voltage for this unit is 97 to 126 V ac (115 V) only. This unit does not accept a 230 V ac source input voltage. Figures 6.51 and 6.52 provide wiring information for this unit. Specifications for this expansion unit are listed below.

Operating Voltage	97 to 126 V ac
AC Frequency	47 to 63 Hz
Maximum Load	25 VA

AC INPUT CIRCUITS (30 to 44)

Input Points	13
Operating Voltage (User Loads)	97-132 V ac
AC Frequency	47-63 Hz
Input Current	9 mA (115 V, 50 Hz) 11 mA (115 V, 60 Hz)
Input Impedance	13 K ohms (50 Hz) 11 K ohms (60 Hz)
Off Current, Maximum	3 mA or less
ON Level	>80 V ac
OFF Level	<20 V ac
OFF to ON Response	10 to 30 ms
ON to OFF Response	10 to 30 ms
Circuit Indicator	Logic Side

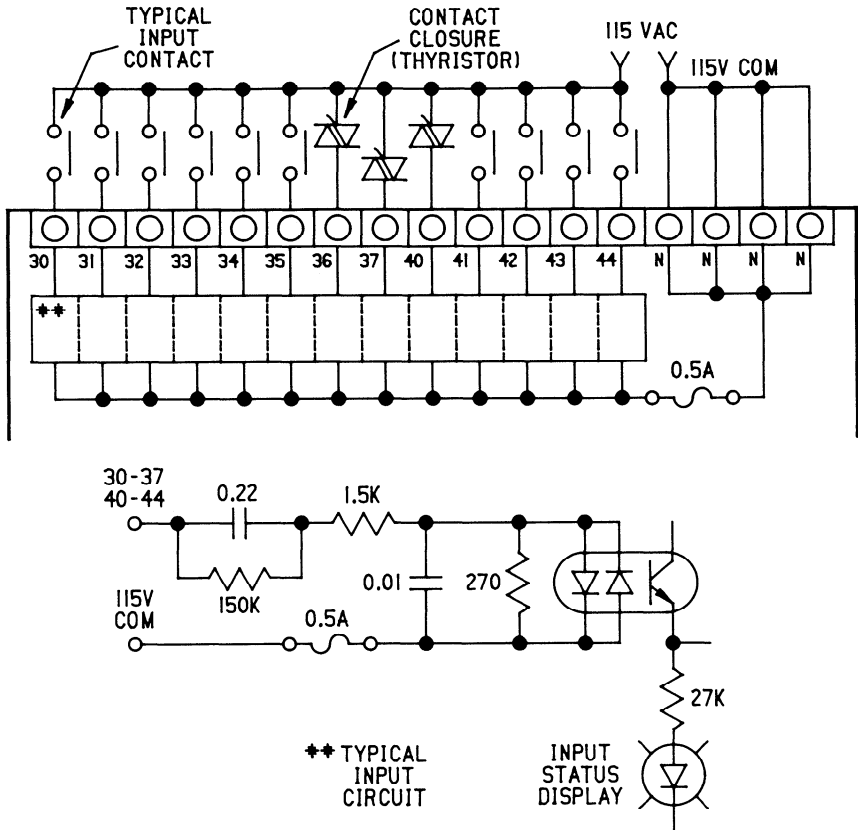

Figure 6.51 WIRING FOR 115 V ac INPUTS FOR UL LISTED EXPANSION UNIT
 TPK.A.41694

AC OUTPUT CIRCUITS (50 to 60)

Output Points	9
Operating Voltage	97 to 132 V ac
AC Frequency	47 to 63 Hz
Maximum Current	1 A Continuous
Maximum Inrush	10 amps for 8 ms
Maximum Leakage Current	3.5 mA at 115 V, 60 Hz
ON Voltage Drop	1.6 V at 1 amp 1.6 V at 0.5 amp
Smallest Recommended Load	25 mA
OFF to ON Response	1 ms
ON to OFF Response	8 to 10 ms (1/2 cycle)
Circuit Indicator	Logic Side

NOTE

Since a surge-absorbing circuit is built-in, there is current leakage through the circuit. A bleeder resistor should be connected across the load to prevent incorrect operation in the event that light loads, such as small relays or neon lamps, are used. Leakage may hold these devices on if a bleeder resistor is not used.

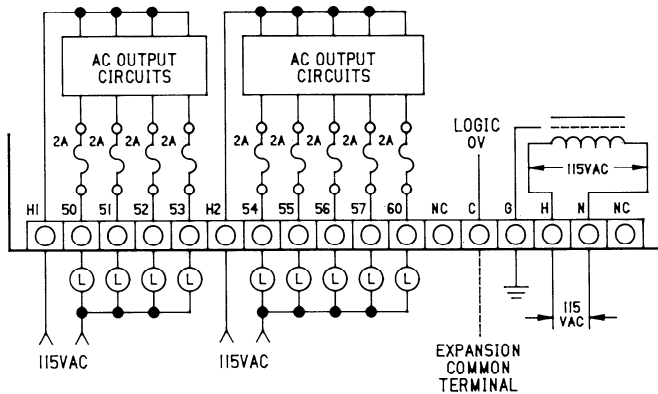

NOTE :

- (L) = TYPICAL LOAD
- N = NEUTRAL
- H = HOT

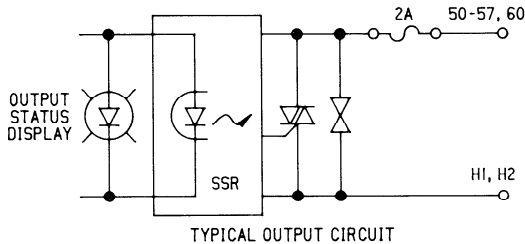

Figure 6.52 WIRING FOR 115 V ac OUTPUTS FOR UL LISTED EXPANSION UNIT

5-SLOT RACK, UL LISTED IC610CHS111

The 5-slot UL listed rack is similar to the existing 5-slot rack, IC610CHS110, in that it has a power supply to the right and slots to contain up to 5 modules. *The power supply for this UL rack requires an input power source of 115 V ac.* This rack does not accept 230 V ac input.

As with the existing 5-slot rack, a terminal board is provided for field wiring connections, refer to Figure 6.53. The two top terminals are for the 115 V ac HOT (H) and NEUTRAL (N) connections. The next two terminals are for connecting an external device to the RUN relay, the next two contacts (+ and -) provide a 24 V dc output voltage at 100 mA for connection to an external sensor, and the bottom terminal is the common (C) connection to an expansion rack.

When used as the first rack in an installation, it must contain the CPU which is placed in the slot next to the power supply. The rack can also be used as the second or third rack in a system if more I/O is required than can be contained in the first rack. A two-position switch on the inside, left of the rack, must be set determined by location of the rack in the system. **For a UL approved installation, do not mix UL approved and non UL racks or modules.** Specifications for this rack are as follows:

AC power Required:	115 V ac, ± 15%
Frequency:	47 to 63 Hz
Maximum Load:	0.8 A, max.
Output Current:	1.4 A, at 5 V dc
	0.8 A at 9 V dc
	0.5 A at 24 V dc

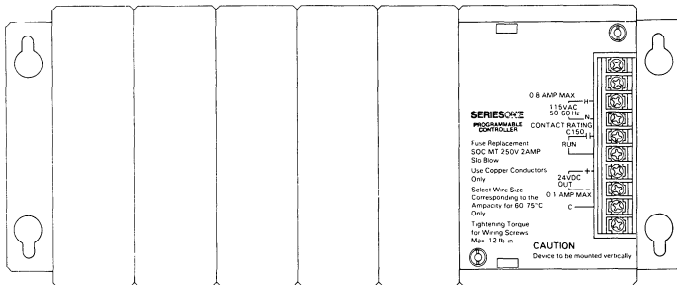
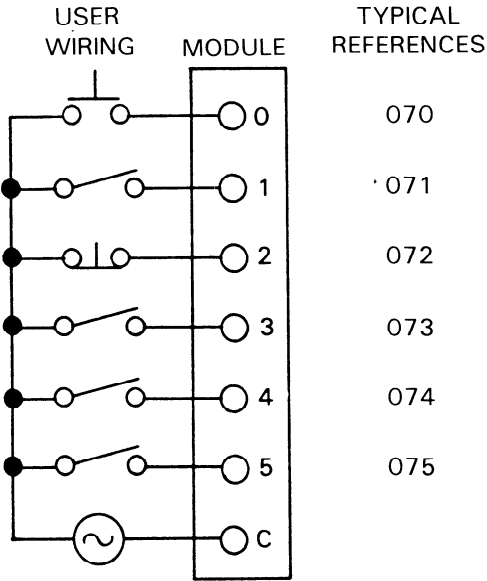

Figure 6.53 UL LISTED 5-SLOT RACK

**115 V ac INPUT MODULE, UL LISTED
IC610MDL135**

This UL listed module provides 6 circuits, each designed to receive a single discrete (ON or OFF) signal from user supplied devices. Examples of these devices include limit switches, pushbuttons, selector switches, and relay contacts. The 6 circuits are grouped together and share a single common terminal. Power to operate the field devices must be supplied by the user. An LED, viewed on the faceplate, provides a visible indication of the ON or OFF state of each circuit. Specifications for each of the 6 circuits are provided below.

Input Points	6
Operating Voltage	97 to 132 V ac
AC Frequency	47 to 63 Hz
Input Current	7 mA per point maximum
Input Impedance	9.5 K ohms
ON Level	>80 V ac
OFF Level	<20 V ac
OFF to ON Response	10 to 30 ms
ON to OFF Response	10 to 60 ms
Circuit Indicator	Field Side
Internal Power Consumption	10 mA at 9 V dc
Units of Load	1 unit (9 V dc)



WIRING DIAGRAM

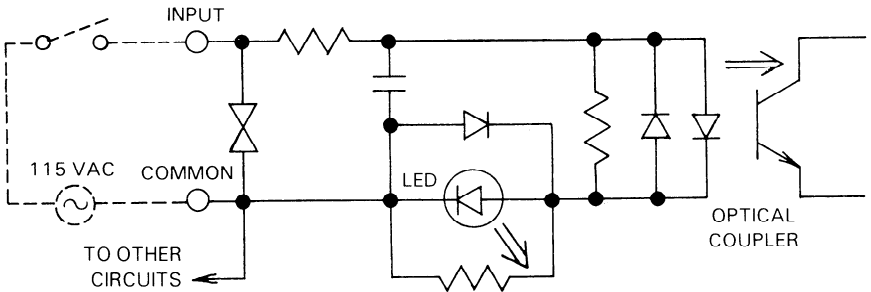

SAMPLE 115 V ac INPUT CIRCUIT

Figure 6.54 WIRING FOR UL LISTED 115 V ac INPUT MODULE

**RELAY OUTPUT MODULE, UL LISTED
IC610MDL181**

This UL listed module provides 5 circuits, each capable of controlling user supplied discrete (ON or OFF) loads. These loads typically include relay coils, motor starters, solenoid valves, annunciation devices and indicator lights. Since this module is not designed to operate with a specific current type such as 115 V ac or 24 V dc, it can be used to control a wide variety of loads and signal types. The relay contact rating for this module is C150.

The 5 circuits are arranged in one group, with 2 common connections, which are tied together internally. Power to operate the field devices must be supplied by the user. An LED, viewed on the faceplate, provides a visible indication of the ON or OFF state of each circuit. Specifications for each of the 5 circuits are listed below.

Outputs	5
Operating Voltage	5 to 132 V ac/dc
AC Frequency	47 to 63 Hz
Contact Rating	C150
Current, Continuous	2.5 Amps
Current, Make, 120 V	15 Amps
Current, Break, 120 V	1.5 Amps
Maximum Leakage Current (across contacts)	1 mA
Smallest Recommended Load	5 mA
Maximum Inrush	5 amps
OFF to ON Response	5 ms
ON to OFF Response	4 ms
Circuit Indicator	Logic Side
Fuses (Internal)	(1) 10 amp, replaceable
Internal Power Consumption	45 mA for each ON circuit at 9 V dc
Units of Load	23 Units at 9 V dc

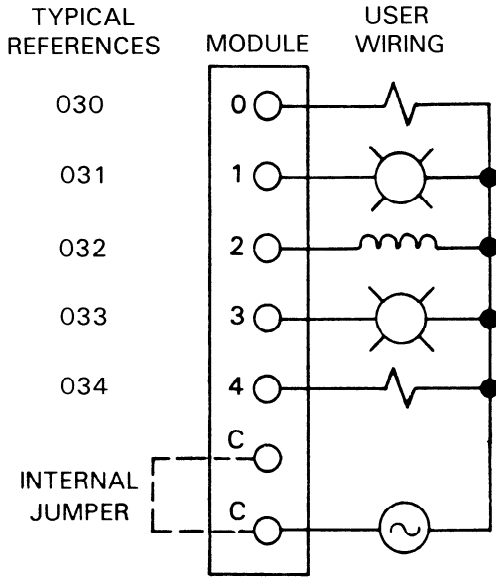

WIRING DIAGRAM

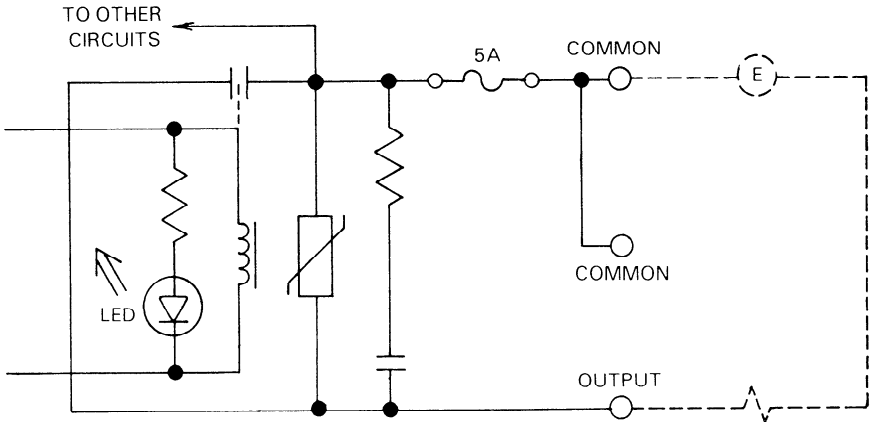

SAMPLE RELAY OUTPUT CIRCUIT

Figure 6.55 WIRING FOR UL LISTED RELAY OUTPUT MODULE

**115 V ac OUTPUT MODULE, UL LISTED
IC610MDL185**

This UL listed module provides 6 circuits, each capable of controlling user supplied discrete (ON or OFF) loads. These loads typically include relay coils, motor starters, solenoid valves, annunciation devices and indicator lights. The 6 circuits are arranged in two groups, with a single common connection for all circuits. Power to operate the field devices must be supplied by the user. An LED, viewed on the faceplate, provides a visible indication of the ON or OFF state of each circuit. Specifications for each of the 6 circuits are listed below.

Outputs	6
Operating Voltage	97 to 132 V ac
AC Frequency	47 to 63 Hz
Maximum Current	0.5 amp (per point)
Maximum Leakage Current	12 mA at 220 V ac, 60 Hz 0.5 mA at 110 V ac, 60 Hz
ON Voltage Drop	0.9 V dc at 1 amp 0.8 V dc at 0.5 amp
Smallest Recommended Load	25 mA
Maximum Inrush	10 amps for 16 ms 5 amps for 100 ms
OFF to ON Response	1 ms
ON to OFF Response	8 to 10 ms (½ cycle)
Circuit Indicator	Logic Side
Fuses (Internal, soldered)	(2) 5 amp (one for each group of three circuits)
Internal Power Consumption	20 mA for each ON circuit at 9 V dc
Units of Load	12 Units at 9 V dc

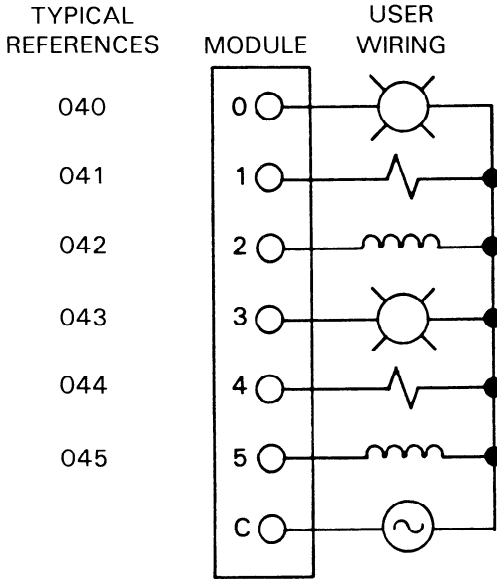

WIRING DIAGRAM

CAUTION

IF THIS MODULE IS WIRED INCORRECTLY OR THE LISTED SPECIFICATIONS ARE EXCEEDED, ANY DAMAGE INCURRED BY THE MODULE OR USER DEVICES CONNECTED TO THE MODULE MAY NOT BE COVERED BY WARRANTY.

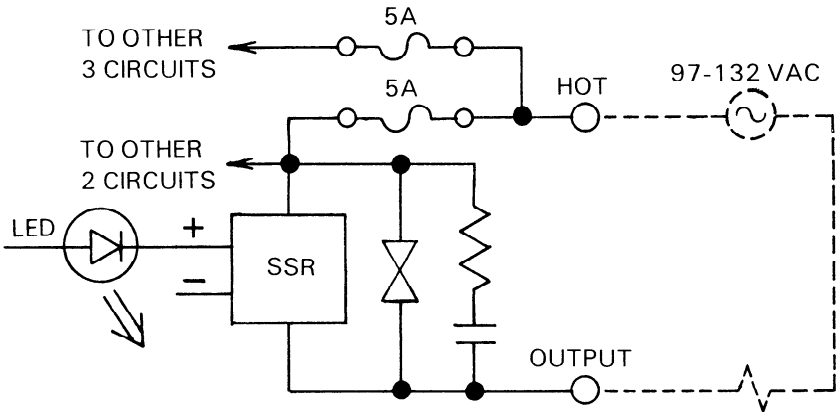

SAMPLE OUTPUT CIRCUIT

Figure 6.56 WIRING FOR UL LISTED 115 V ac OUTPUT MODULE

**24 V dc SINK LOAD INPUT (16 Circuits)
With Removable Terminal Board
IC610MDL107**

This module provides 16 circuits, each designed to receive a single discrete (ON/OFF) signal from user supplied devices. This module has 16 LED status indicators to reflect the ON or OFF status of each of the 16 circuits. Typical input devices include limit switches, pushbuttons, selector switches, and relay contacts. 24 V dc power to sense the state of these inputs is provided by the rack power supply; therefore, no external power source is required for this module. The 16 circuits are divided into 2 groups, with each group having its own common terminal. The 2 common terminals are tied together internally.

The 16 input circuits are connected to user devices through a removable socket type terminal board. Following are specifications for each of the 16 circuits:

Input Points	16
Maximum Voltage (Open Circuit)	36 V dc
Input Current	17 mA
ON Level*	0 to 3 V dc
OFF Level*	19 to 24 V dc
OFF to ON Response	3 to 15 ms
ON to OFF Response	4 to 15 ms
Maximum OFF Leakage	1 mA
Minimum ON Current	5 mA
Circuit Indicator	Field Side
Internal Power Consumption	25 mA (@ 9 V dc, Maximum 16 circuits ON) 14 mA for each ON circuit @ 24 V dc
Units of Load	3 units (@ 9 V dc 23 units (@ 24 V dc
Weight	6.0 oz (170 g)

*Voltage levels measured between common and input terminals (across input device).

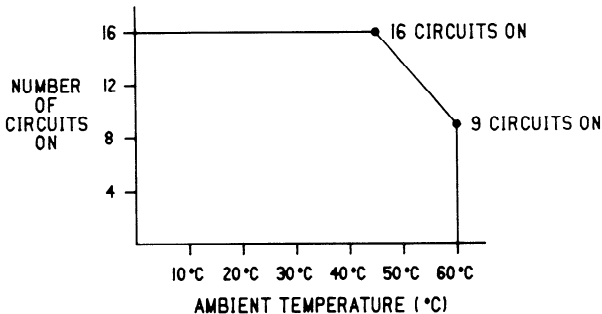
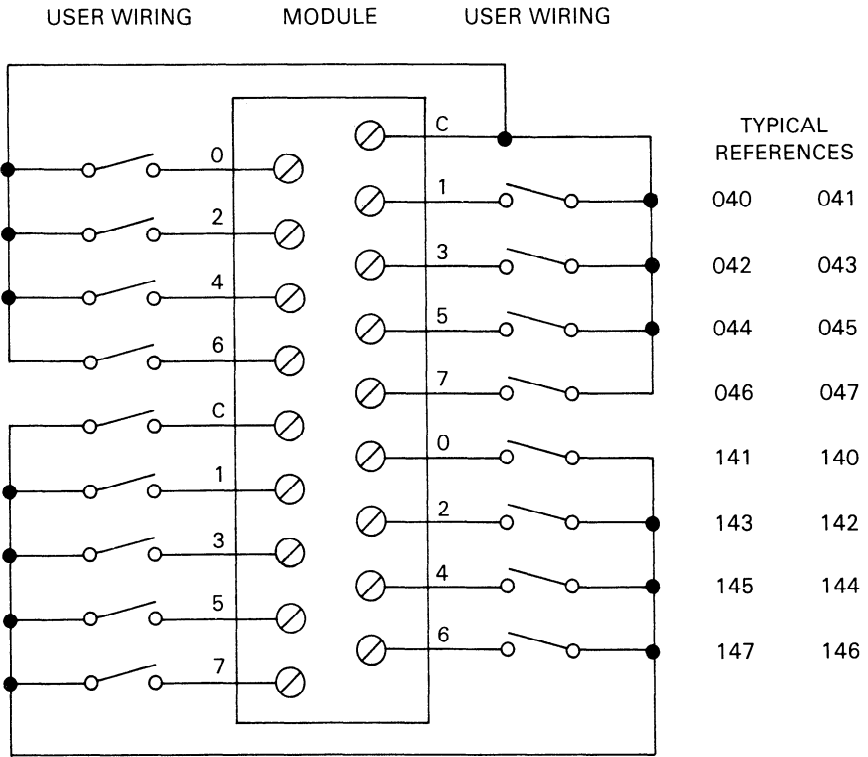
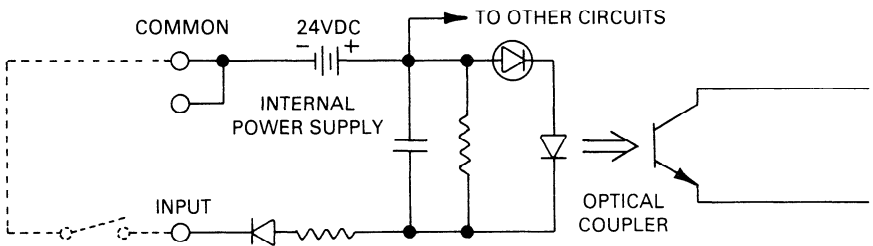

Figure 6.57 I/O POINTS VS TEMPERATURE CHART



WIRING DIAGRAM



SAMPLE INPUT CIRCUIT

Figure 6.58 WIRING FOR 16 CIRCUIT, 24 V dc SINK LOAD INPUTS

**24 V ac/dc SOURCE INPUT (16 Circuits)
With Removable Terminal Board
IC610MDL112**

This module provides 16 input circuits, with LED indicators, each designed to receive a single discrete (ON/OFF) signal from user supplied devices. Typical input devices include pushbuttons, limit switches, selector switches and relay contacts. These input circuits can interface to either 24 V ac signals or 24 V dc source-type signals, thereby allowing the module to interface to input devices that provide their own voltage. In addition, the module can be connected as a sink input. When using the sink configuration, the user must supply the source of power for the input devices, as when used in the source input configuration. Following are specifications for each of the 16 circuits.

	AC INPUT	DC INPUT
Input Voltage (Source or Sink)	14 to 30 V ac, 50-60 Hz	20-28 V dc
Input Current	12 mA @ 24 V ac	12 mA @ 24 dc
ON Level	14 to 30 V ac	14 to 30 V dc
OFF Level	0 to 3 V ac	0 to 3 V dc
OFF to ON Response	5 to 30 ms	5 to 25 ms
ON to OFF Response	5 to 30 ms	5 to 25 ms
Circuit Indicator	Logic Side	Logic Side
 Internal Power Consumption		9 V dc, 130 mA (maximum) Typical, 25 mA + 4.5 mA for each ON circuit
 Units of Load Weight		13 6 oz (170 g)

User devices are connected to screw terminals on the removable connector mounted on the faceplate of this module. Each screw terminal will accept up to one No. 12 AWG wire or two No. 14 AWG wires. The ON/OFF state of each circuit is indicated by an LED located in the logic side of each circuit. The 16 circuits are divided into 2 groups of 8, each with its own common. The two commons, CA and CB are isolated from each other internally. Each input can accept either an AC input or a DC input.

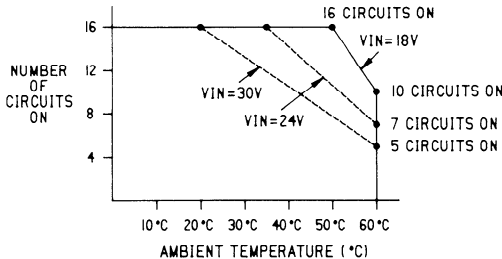
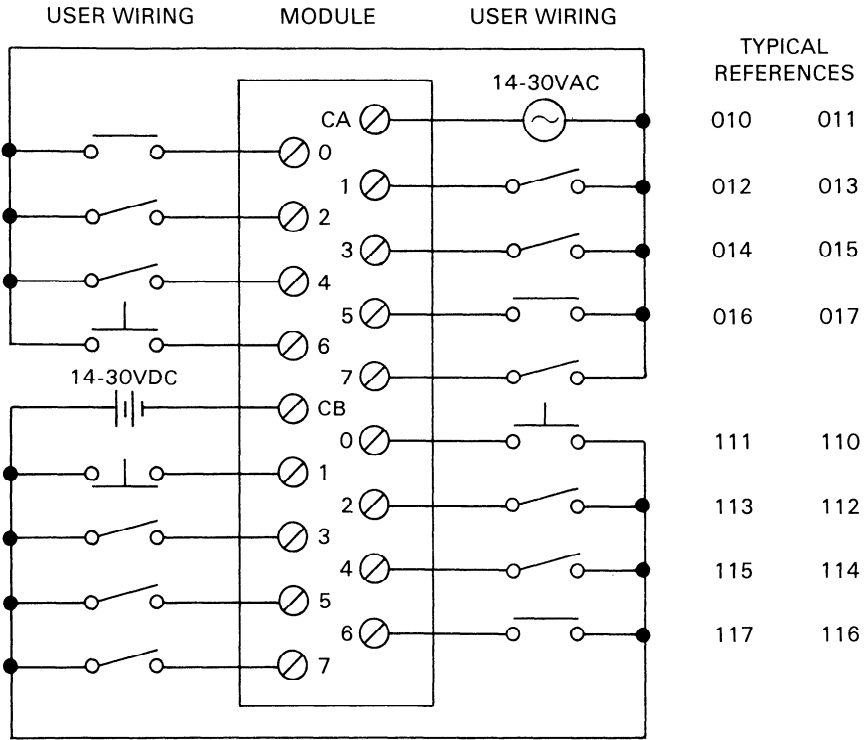
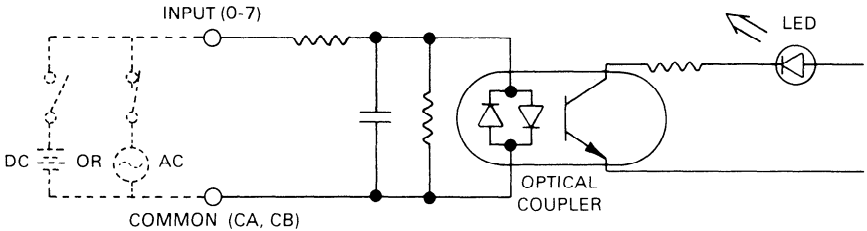

Figure 6.59 I/O POINTS VS TEMPERATURE CHART



WIRING DIAGRAM



SAMPLE INPUT CIRCUIT

Figure 6.60 WIRING FOR 16 CIRCUIT 24 V ac/dc SOURCE LOAD INPUTS

**24 V dc SINK OUTPUT (16 Circuits)
With Removable Terminal Board
IC610MDL157**

This module provides 16 circuits, each designed to be capable of controlling user supplied discrete (ON/OFF) loads. There are 16 LEDs on the faceplate, which are status indicators to reflect the ON or OFF status of each of the circuits. Typical loads include relay coils, motor starters, solenoid valves, and indicator lights. The 16 circuits are referenced to a single DC power source that must be supplied by the user. Output switching capacity of this module is 0.5 A at 24 V dc. The output switching circuitry is arranged in 2 groups with 8 circuits in each group. Each group is protected by a 3 amp fuse.

The 16 circuits are connected to user loads through a removable socket type terminal board. Following are specifications for each of the 16 circuits:

Output Points	16
Operating Voltage	5-24 V dc
Peak Voltage	40 V dc
ON Voltage Drop, Typical	1.0 V dc @ 0.5 amp
ON Voltage Drop, Maximum	2.0 V dc @ 0.5 amp
Maximum Current*	0.5 amp
Maximum Leakage Current	0.11 mA @ 40 V dc
Maximum Inrush	3 amp for 20 ms 1 amp for 100 ms
OFF to ON Response	0.1 ms
ON to OFF Response	0.1 ms
Fuse (Internal)	3 amp (In Output Common Line, one for each group of 8)
Internal Power Consumption	9 V dc: 3 mA + 2.3 mA for each ON circuit 24 V dc: 6 mA for each ON circuit
Units of Load	4 units @ 9 V dc 10 units @ 24 V dc
Weight	5.6 oz (160 g)

*Maximum load current is dependent upon ambient temperature as shown below.

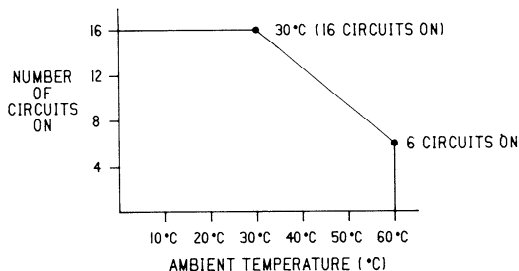
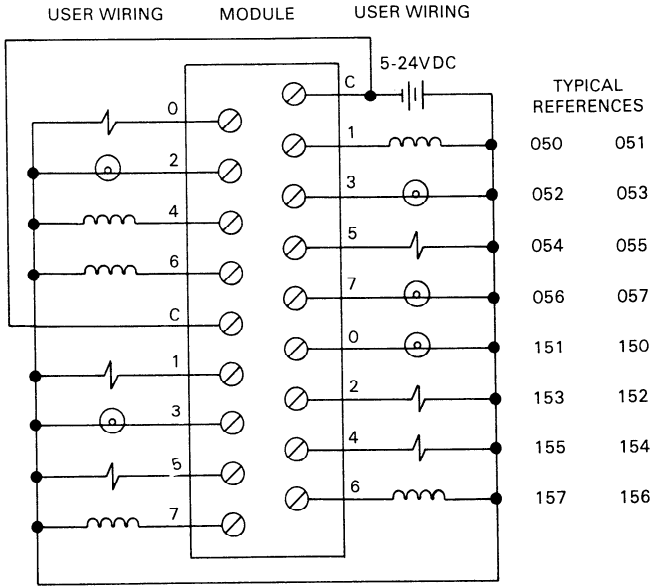

Figure 6.61 I/O POINTS VS TEMPERATURE CHART



WIRING DIAGRAM

The following rules should be used when applying this module.

1. Each group of 8 outputs is limited to 2A total current.
2. The maximum current for each array of 4 outputs (0-3), (4-7) is:

1 point on - .7 amps,	2 points on - .5 amps each
3 points on - .4 amps each,	4 points on - .35 amps each

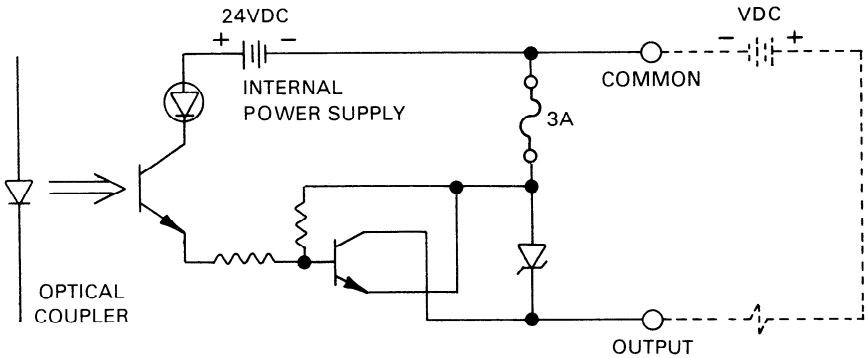

SAMPLE OUTPUT CIRCUIT

Figure 6.62 WIRING FOR 16 CIRCUIT 24 V dc SINK OUTPUTS

**24 V dc SOURCE OUTPUT (16 Circuits)
With Removable Terminal Board
IC610MDL158**

This module provides sixteen 24 V dc source output circuits, each capable of controlling user supplied discrete (ON/OFF) loads. The output switching capacity of this module is 0.5 amps at 24 V dc. Typical loads that can be controlled by this module are motor starters, relay coils, solenoid valves, and indicator lights. The output switching circuits on the module are arranged in 2 groups with 8 circuits in each group. Each group of 8 output circuits is protected by a 5 amp fuse. All 16 circuits can be referenced to a single source of dc power or each group of 8 can be referenced to a separate source of power. Field connections are made to screw terminals on a removable terminal board mounted on the module's faceplate. Each terminal will accept up to one No. 12 AWG wire or two No. 14 AWG wires. The operating state, either ON or OFF is indicated by a corresponding LED viewed on the module's faceplate. Following are specifications for each of the 8 circuits.

Output Points	16
Operating Voltage	5 to 24 V dc
Peak Voltage	40 V dc
ON Voltage Drop	Maximum 1.5 V dc 0.8 V dc @ 0.5 amp (Typical) 0.7 V dc @ 0.1 amp (Typical)
Maximum Current*	0.5 amps
Maximum Leakage Current	10 μ A @ 40 V dc
OFF to ON Response	0.1 ms (Resistive)
ON to OFF Response	1.0 ms (Resistive)
Circuit Indicator	Logic Side
Fuses (Internal)	(2) 5 amp (in output common line, one for each group of 8 circuits)
Internal Power Consumption	12 mA for each ON circuit
Units of Load	20 units @ 9 V dc
Weight	7.1 oz (200 g)

*Maximum load current is dependent on ambient temperature as shown below.

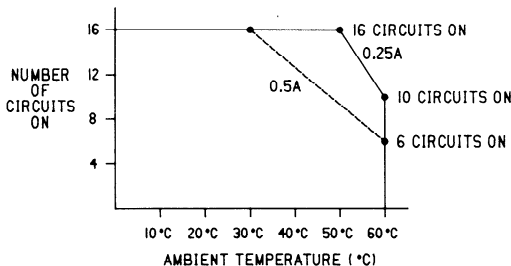
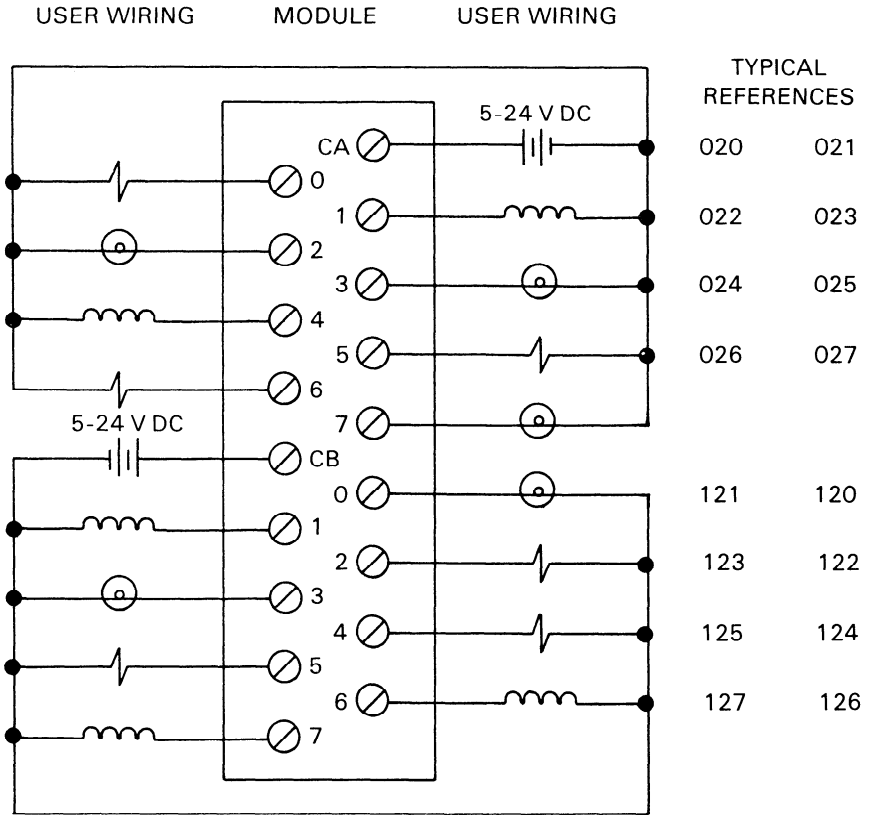
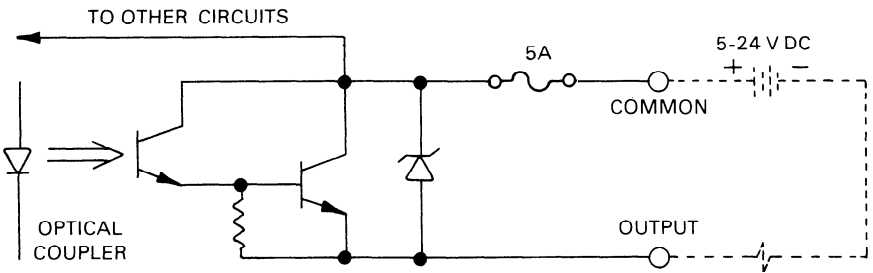

Figure 6.63 I/O POINTS VS TEMPERATURE CHART



WIRING DIAGRAM



SAMPLE OUTPUT CIRCUIT

Figure 6.64 WIRING FOR 24 V dc SOURCE OUTPUTS

**RELAY OUTPUT (16 Circuits)
With Removable Terminal Board
IC610MDL182**

This module provides 16 circuits each capable of controlling user supplied discrete (ON/OFF) loads. Typical loads include relay coils, motor starters, solenoid valves, and indicator lights. Since this module is not designed for a specific current type such as 115 V ac or 24 V dc, it can be used with a wide variety of loads and signal types. The 16 circuits are divided into two groups with 8 circuits each. Each group can be supplied from a separate power source. Power to operate the field devices must also be supplied by the user. The ON/OFF status of each circuit is indicated by an LED, which is located on the logic side of the circuitry. The 16 output circuits are connected to user loads through a removable socket type terminal board. Following are specifications for each of the eight circuits:

Outputs	16
Operating Voltage	5 to 220 V ac 5 to 30 V dc
AC Frequency	47-63 Hz
Maximum Current*	2 amps (Resistive) 8 amps per Common (maximum)
Maximum Leakage Current (Across Contacts)	0.1 mA
Smallest Recommended Load	5 mA
Maximum Inrush	2 amps
OFF to ON Response	10 ms
ON to OFF Response	10 ms
Circuit Indicator	Logic Side
Fuses (Recommended, External)	2 amp in series with load
Internal Power Consumption	30 mA for each ON Circuit @ 9 V dc
Units of Load	48 units
Weight	8.5 oz (240 g)

*Since non-solid state devices are used as the power switching devices, the following limitations must be observed for reliable operation:

Table 6.12 MAXIMUM CURRENT VS LOAD TYPE FOR RELAY OUTPUTS

OPERATING VOLTAGE	MAXIMUM CURRENT FOR LOAD TYPE			TYPICAL LIFE (OPERATIONS)
	RESISTIVE	LAMP	SOLENOID	
220 V ac	2 Amp	0.25 Amp	0.25 Amp	100,000
220 V ac		0.03 Amp	0.03 Amp	800,000
110 V ac	2 Amp	0.25 Amp	0.25 Amp	100,000
110 V ac		0.05 Amp	0.05 Amp	650,000
24 V ac	2 Amp	0.25 Amp	0.25 Amp	100,000

NOTE

Lamp loads are defined as a X10 inrush with a power factor (PF) of 1.00 and when turned OFF represent a PF of 1.00. Solenoids are defined with a X10 inrush, a PF of 0.65, and when turned OFF represent a PF of 0.35.

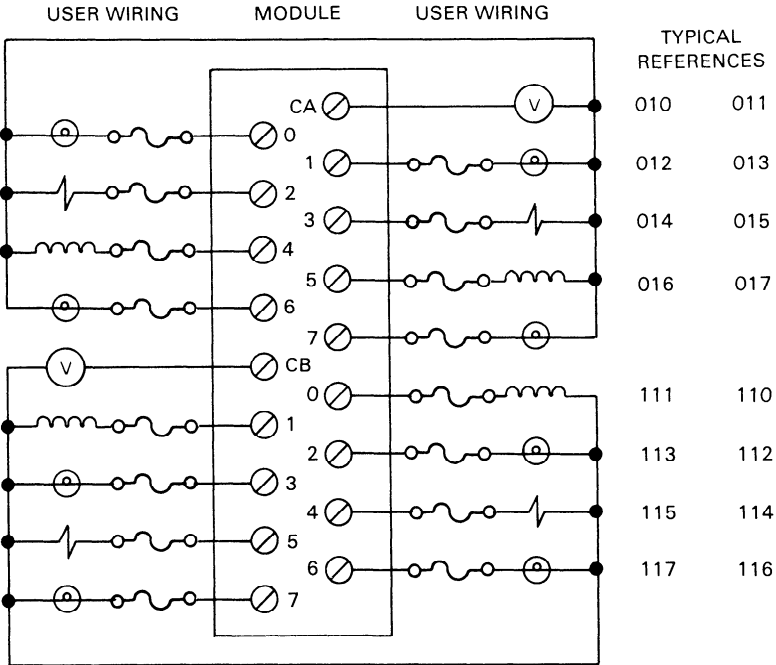

WIRING DIAGRAM

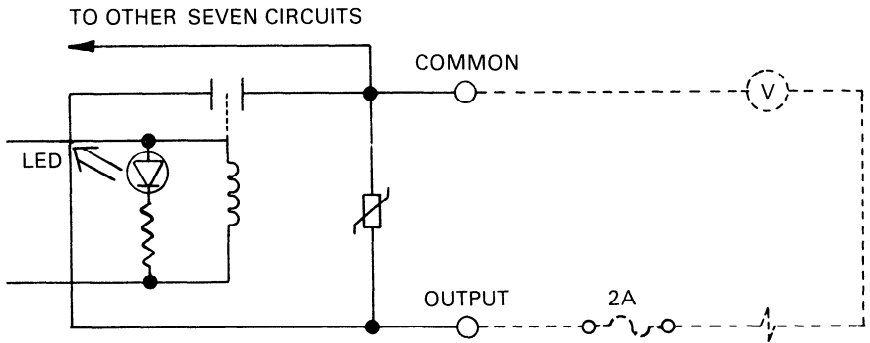

SAMPLE OUTPUT CIRCUIT

Figure 6.65 WIRING FOR 16 CIRCUIT RELAY OUTPUTS

CHAPTER 7 MAINTENANCE

INTRODUCTION

The Series One Junior PC is designed to provide trouble-free operating during its lifetime. However, occasionally situations requiring corrective action do occur and it is important to be able to quickly identify the source of such situations and correct them. The overall control system must be evaluated, since many times the need for corrective action originates outside of the Series One Junior.

TROUBLESHOOTING AIDS

The advantages provided by the Series One Junior design are indicators and built-in aids to troubleshooting not only the PC, but also the overall control system. The main diagnostic tool is the programmer that can be easily attached to the Series One Junior. The programmer is an excellent tool for monitoring the status of the overall control system. When troubleshooting a Series One Junior control system, make a habit of having a programmer with you.

BASIC TROUBLESHOOTING PROCEDURE

The following questions should be asked and appropriate action taken to negative answers. At the end of the list of questions are step by step procedures to be followed to replace various parts of the Series One Junior. All major corrective action can be accomplished by replacing either the basic unit or I/O modules. No special hand tools are required except for a screw driver and voltmeter. There is no requirement for an oscilloscope, highly accurate voltage measurements (digital voltmeters), or specialized test programs. Refer to Figure 7.1 for location of the referenced indicators.

1. Is the PWR (Power) light ON? If not, measure power at the AC terminals (98-126 Vac or 195-253 Vac as appropriate) on basic units using an AC power source. For units requiring a DC power source, measure the DC voltage between the +24 V dc and 0 V terminals. If the appropriate AC or DC power is not present, locate the source of the problem external to the Series One Junior. Adequate AC or DC power but no PWR light requires verification of fuses, then replacement of the basic unit if necessary.
2. Is the CPU light OFF? If ON, check which error code is displayed, refer to Table 4.1 for error code definitions and take appropriate action.
3. Is the RUN light ON? If not, check for cause such as the programmer in the PRG or LOAD position or programming errors. If the RUN light is OFF and the programmer is not connected, or the programmer is in the RUN mode without an error code being displayed, replace the basic unit.

4. Is BATT light ON? If yes, replace the battery. Since the BATT light is only a warning level, the program may be unaltered even if the battery is low. After replacing the battery, examine the program or test the Series One Junior operation. If a fault is located reload the program from tape which was recorded at the completion of initial system programming.
5. If an expansion rack is included in the system, and the CPU is operating, the RUN relay on the expansion rack can be very useful in verifying operation of the expansion rack power supply. If the RUN relay is not closed (high resistance) check the AC or DC power supply as in step 1. Adequate AC or DC power and an open relay is an indication that the expansion rack should be replaced.

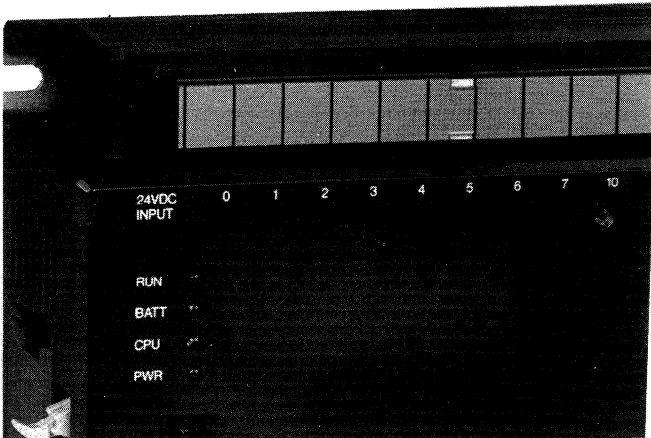

Figure 7.1 SERIES ONE JUNIOR TROUBLESHOOTING INDICATORS

GENERAL TROUBLESHOOTING PROCEDURE

Additional procedures depend upon knowledge of the logic installed by the user. The following steps are more general in nature and should be modified or adjusted as necessary to meet your specific application. There are no better troubleshooting tools than common sense and experience. First attach the programmer and place it in the RUN mode, then follow these steps:

1. If the Series One Junior has stopped with some outputs energized or basically in mid-stream, locate the signal (input, timer, coil, sequencer, etc.) that should cause the next operation to occur. When attached, the programmer will display the ON or OFF condition of that signal.
2. If the signal is an input, compare the programmer state with the LED on either the basic unit or on the input module in the expansion rack. If they are different, replace the basic unit or the input module as applicable.

3. If the input state and the LED on the basic unit or input module agree, compare the LED status and the input device (pushbutton, limit switch, etc.). If they are different, measure voltage at the input module (refer to Chapter 6 for typical I/O wiring). If voltage so indicates, replace the I/O device, field wiring, or power source; otherwise, replace the basic unit or the input module in the expansion rack.
4. If the signal is a coil wired to a field device, compare its status to the LED on the basic unit or the output module. If they are different, verify the source of field power to ensure that excitation voltage is available. If field power is not present, examine the power source and its wiring. If the proper field power is available but status is wrong at the basic unit output terminal or the output module in the expansion rack, replace the basic unit or the output module, as applicable.
5. If the signal is a coil, and either there is no output module or the output is the same as the coil state, examine logic driving the output with the programmer and a hard copy of the program. Proceeding from right towards left, locate the first contact that is not passing power that is otherwise available to it from the immediate left. Troubleshoot that signal per steps 2 and 3 above if it is an input, or 4 and 5 if it is a coil. Ensure that Master Control Relays are not impacting operation of the logic.
6. If multiple modules in the expansion rack appear to require replacement, verify that the I/O Expansion cable is connected properly at the Series One Junior and at the I/O Expansion module. If there is a problem in the connection between the basic unit and the I/O Expansion module, an error code will be generated and displayed on the programmer. Compare the error code with the error codes listed in Table 4.1 and take the appropriate action.
7. If the signal is a timer that has stopped at a value below 999.9, other than 0000, replace the basic unit.
8. If the signal is the control over a counter, examine the logic controlling the reset first and then the count signal. Follow steps 2 through 5 above.

REPLACEMENT OF COMPONENTS

The following procedures provide details on the steps to be followed when replacing various components of the system.

REPLACING A BASIC UNIT OR I/O EXPANSION UNIT

1. Turn OFF AC or DC power source, as applicable, and remove the programmer (if installed).
2. Remove the plastic covers from over the top and bottom terminal strips.
3. Disconnect power source wiring from terminals on the bottom right.

4. Disconnect field wiring from input terminals at top of unit and output terminals at the bottom of the unit. Disconnect the I/O Expansion cable, if used.
5. Remove bottom two bolts holding the basic unit in place. Loosen but do not remove the top bolts.
6. Slide the basic unit up and then pull forward to clear top mounting bolts.
7. Install the new basic unit onto the top mounting bolts.
8. Insert bottom bolts and tighten all four mounting bolts.
9. Reconnect the field wiring to the same top or bottom terminals from which it was removed.
11. Reconnect power wiring to terminals on the right. Reinstall the plastic cover over the top and bottom terminals. Reconnect I/O Expansion cable, if used.
12. Verify proper operation of the entire system to ensure that the new basic unit is operating properly and the program is not altered.

REPLACING EXPANSION RACK I/O MODULES

1. Turn OFF power to both the basic unit and the expansion rack.
2. Remove the plastic cover from over the terminals on the I/O module to be replaced. Only field wiring on the faulty module needs to be removed.
3. Disconnect field wiring from all I/O module terminals. Label each wire or otherwise note the position of the installed wire for later reconnection.
4. Squeeze I/O module at the front, top and bottom to release the securing tabs.
5. Pull the I/O module straight out.
6. Insert the new I/O module, aligning printed circuit boards first, into the bottom tracks.
7. Rotate the module upwards slightly to engage the top tracks.
8. Firmly push the I/O module into the rack until both tabs snap into place.
9. Reconnect field wiring and replace the plastic cover.
10. Reapply power to the basic unit, then to the expansion rack. Check operation of system, especially the I/O module that was just replaced.

REPLACING AN EXPANSION RACK

1. Turn OFF power and remove the programmer (if installed).
2. Remove the plastic cover and disconnect power wiring from the terminal strip on the right side of the rack. Disconnect the I/O Expansion cable.
3. Remove all I/O modules and filler modules, if any are installed. I/O wiring does not have to be disturbed if a service loop was provided during the original installation. Note the position of each module for proper reinstallation.
4. Remove the bottom two bolts holding the expansion rack in place. Loosen but do not remove the top bolts.
5. Slide the expansion rack up and then pull forward to clear the top mounting bolts. Set the unit aside.
6. Install the new expansion rack by placing the 2 top mounting holes onto the top mounting bolts.
7. Insert the 2 bottom bolts and tighten all four mounting bolts.
8. Install I/O modules in exactly the same slots from which they were removed.

WARNING

PLACING A MODULE IN THE WRONG SLOT CAN CAUSE INCORRECT AND DANGEROUS OPERATION OF THE CONTROL SYSTEM. HOWEVER, IT WILL NOT DAMAGE THE MODULE.

9. Reconnect power wiring to terminals on the right. Reinstall the plastic cover over the power terminals. Reconnect the I/O Expansion cable.
10. Verify proper power wiring and then turn power ON. Carefully check operation of entire system to ensure that the I/O modules are in their proper locations and the program is not altered.

REPLACING THE LITHIUM BATTERY

1. If the BATT light is ON or blinking, the lithium battery should be replaced, since it will not properly maintain the CMOS memory during a power loss condition.
2. To access the battery, remove the battery access cover (refer to Figure 7.2) located on the left side of the Series One Junior. The cover is easily removed by pressing down on the tab until the access cover pulls away from the unit.
3. Remove the battery by depressing the connector tab on the unit side of the connector, and at the same time pull the battery side of the connector towards you until the 2 parts are separated. There is sufficient capacitance in the system to retain the CMOS memory contents even without the battery for 20 minutes.



Figure 7.2 BATTERY LOCATION

WARNING

THE LITHIUM BATTERY SHOULD BE HANDLED WITH CARE. DO NOT DISCARD THE BATTERY IN FIRE. DO NOT ATTEMPT TO RECHARGE THE BATTERY. DO NOT SHORT THE BATTERY. THE BATTERY MAY BURST, BURN OR RELEASE HAZARDOUS MATERIALS.

4. Remove the battery from the retaining clips
5. Insert the new battery, catalog no. IC610ACC150, into the retaining clips by placing the battery over the clips and pressing down firmly on the battery until it snaps into place.
6. Connect the battery by sliding the battery side of the connector into the basic unit's side of the connector until it snaps into place.
7. Replace the battery access cover.
8. Verify that the BATT light is OFF, and that the program is intact and operating properly. If necessary, reload the system from a tape recording of the program made after initial system programming.

FUSING INFORMATION

Each of the Series One Junior basic units has built-in fuse protection to prevent damage to the output circuitry. Fuses are installed in the units in one of two ways, either mounted in clips or soldered into the circuit. The circuit illustrations for each unit in Chapter 6, show how the fuses are connected in each of the output circuits. The current rating and fuse type used in each of the basic units is as listed in Table 7.1.

Table 7.1 SERIES ONE JUNIOR FUSE LIST

SERIES ONE JUNIOR CATALOG NUMBER	TYPE OF FUSE USED	CURRENT RATING	CIRCUIT CONNECTION
IC609SJR100	pico, fast blow	2 A (all ckts)	soldered
IC609SJR101 (1)	pico, fast blow	2 A (all ckts)	soldered
IC609EXP101 (2)	pico, fast blow	2 A (all ckts)	soldered
IC609SJR110	miniature, normal blow	2 A (C1) 5 A (C2, C3)	fuse clips
IC609SJR114	miniature, normal blow	2 A (C1) 5 A (C2, C3)	fuse clips
IC609SJR120	miniature, normal blow	2 A (C1) 5 A (C2, C3)	fuse clips
IC609SJR121	miniature, normal blow	2 A (C1) 5 A (C2, C3)	fuse clips
IC609SJR124	miniature, normal blow	2 A (C1) 5 A (C2, C3)	fuse clips
IC609EXP110	fast blow	5 A (C1, C2)	fuse clips
IC609EXP120	normal blow	5 A (C1, C2)	fuse clips
IC609EXP121	normal blow	5 A (C1, C2)	fuse clips

- (1). UL listed basic unit
- (2). UL listed expansion unit

The IC609SJR100 unit has 9 fuses, with each circuit being individually fused. Each of these is a fast blow pico fuse and is soldered in place. Each fuse is rated at 2 amps. These fuses are physically located in each output line, between the output circuitry and the output terminal (17 through 27). The other units each have 3 fuses, which are miniature, normal blow glass fuses. Each of these fuses is mounted in a fuse holder located on a printed circuit board inside of each unit. One fuse is in each common line, between the common terminals, C1, C2, C3 and the output circuitry. The fuse in the C1 line for the isolated circuit is rated at 2 amps and the fuses in the C2 and C3 lines (1 fuse for each group of 4 circuits) are rated at 5 amps each. The fuses in all of these units are for protection of the output circuitry and should be replaced by a qualified person in the event that a fuse does blow. The DC I/O Expansion units have two 5 amp fuses, one in the C1 line and one in the C2 line.

NOTE

Although fuses are built into each Series One Junior, as a convenience, it is recommended that external fusing be installed by the user in series with the output circuits. The external fuse should have a lower current rating than the internal fuse. For example, the internal fuse current rating for the IC609SJR100 is 2 amps; use 1.5 amp fuses externally. In this manner, if a surge should occur, it would blow the external fuse. The external fuse could then be quickly replaced, without the requirement of disturbing the field wiring, dismantling the Series One Junior and removing the rear cover plate in order to gain access to the internal fuses.

REPLACING A FUSE

If an internal fuse should blow in one of the circuits in a Series One Junior, use the following procedure to access and replace the fuse.

1. Turn OFF the AC or DC power source, as applicable, and remove the programmer (if installed).
2. Remove the plastic covers from over the top and bottom terminal strips.
3. Disconnect power source wiring from terminals on the bottom right.
4. Disconnect field wiring from input terminals at top of unit and output terminals at the bottom of the unit.
5. Remove bottom two bolts holding the basic unit in place. Loosen but do not remove the top bolts.
6. Slide the basic unit up and then pull forward to clear the top mounting bolts.
7. Place the unit on a work bench so that the bottom metal cover plate is accessible.
8. Remove the 4 largest phillips-head screws. One of these screws is located in each of the 4 corners of the cover plate. These screws fasten the cover plate to the black plastic cover.
9. The circuit boards, terminal strips and other hardware items are physically attached to the metal bottom cover plate. The black plastic cover plate must now be detached from the rest of the unit.

-
10. Turn the unit up so that the front of the unit is facing you. The black plastic cover can now be removed by gently pulling the cover away from the rest of the unit. The battery compartment access cover must be loosened so that it can be pulled through the cutout into which it is placed. Ensure that the top and bottom terminal strips and the I/O expansion connector do not interfere with removal of the cover.
 11. After the top cover has been removed, access to the fuses is then possible. The fuses in each of the units are physically located on the bottom circuit board in the lower left of the unit (near the programmer connector).
 12. If any of the glass fuses in one of the DC units is blown it can be removed by carefully pulling the defective fuse up and out of its retaining clip.
 13. If one of the pico fuses in an AC unit is blown, it should be replaced by a qualified person. These fuses must be desoldered for removal. To do this, the bottom cover plate must be completely detached from the lower printed circuit board by removing the remaining phillips-head screws. The fuse leads must be desoldered carefully, since the unit could be damaged by excessive heat.
 14. After replacing the defective fuse, replace the bottom cover plate and the black plastic cover. Then remount the unit and reconnect field and power wiring. Your unit is then ready for normal operation.

CHAPTER 8 APPLICATIONS

APPLICATION 1 — ONE-SHOTS

In many applications, a signal is required that is valid for a very short time period. These signals are called one-shots and are generated by transitions (OFF to ON, or ON to OFF) of a control signal. They are valid for exactly one scan, which is the shortest signal available within the Series One Junior. Timing for typical One-Shots is as follows:

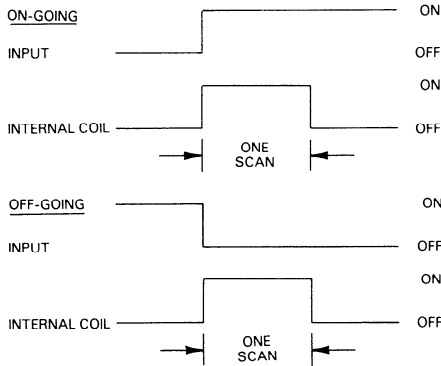

Figure 8.1 TYPICAL ONE-SHOT TIMING

In this example, input 01 is the control signal and coil 160 the resulting one shot. Logic for these one-shots is shown below.

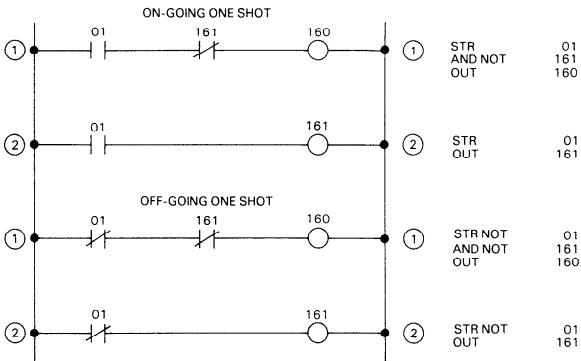

Figure 8.2 TYPICAL ONE-SHOT LOGIC

APPLICATION 2 — FLIP FLOP

This logic reverses states (ON/OFF/ON/OFF, etc.) each time a control signal is energized. It is similar to flipping a coin and alternating the results (Heads/Tails/Heads/Tails etc.). In this example, the Flip/Flop changes state on the OFF to ON transition of the control signal. A typical timing diagram is as follows:

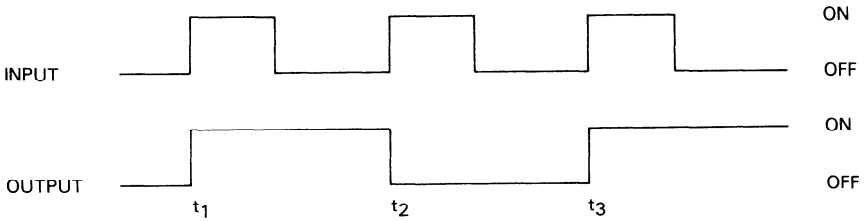

Figure 8.3 TYPICAL FLIP-FLOP TIMING DIAGRAM

In the following typical logic, input 01 is the control signal and output 20 is the flip/flop.

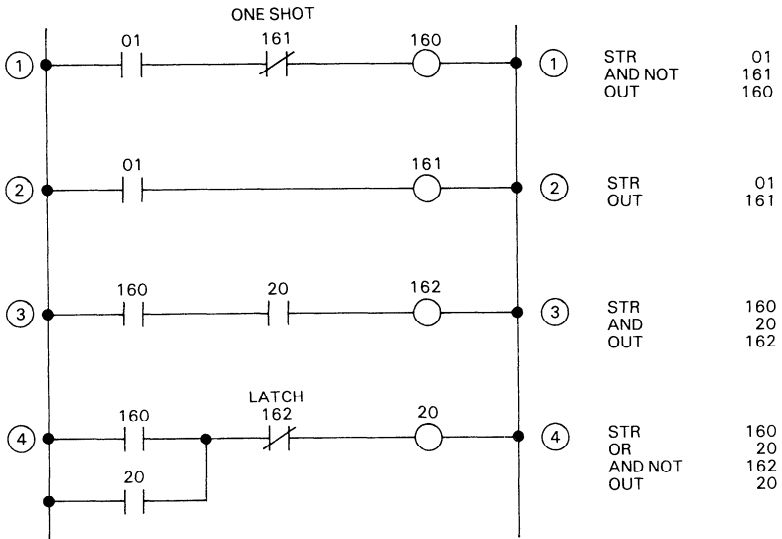

Figure 8.4 TYPICAL FLIP-FLOP LOGIC

APPLICATION 3 — EVENT/TIME DRUM

Many control requirements can be defined as a sequence of established states for each output. The decision to shift from one step to another can be based upon time or specific input states. To illustrate this concept, the following 6 step example is provided. The control on incrementing the step is a confirmation of both events (for example, input 11) and a time value (for example, timer 601).

Step Number	Input	Time	20	21	22	23	24	25	26	27
1	10	T600	0	1	1	0	1	1	1	0
2	11	T601	0	0	0	0	1	0	0	1
3	12	T602	0	1	1	1	0	1	1	0
4	13	T603	1	1	1	0	0	0	1	0
5	14	T604	1	0	1	1	1	1	1	1

Each step can have different output states and more or less control can be implemented as the application requires. The ladder diagram required to implement this function is as follows:

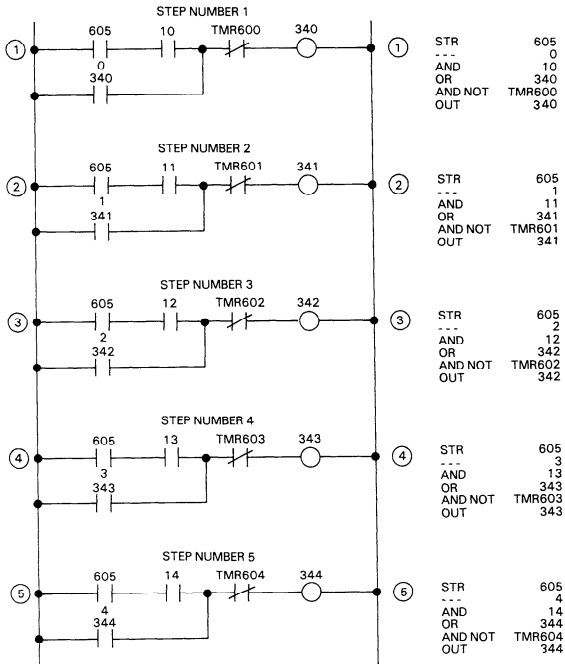

Figure 8.5 EVENT/TIME DRUM LOGIC

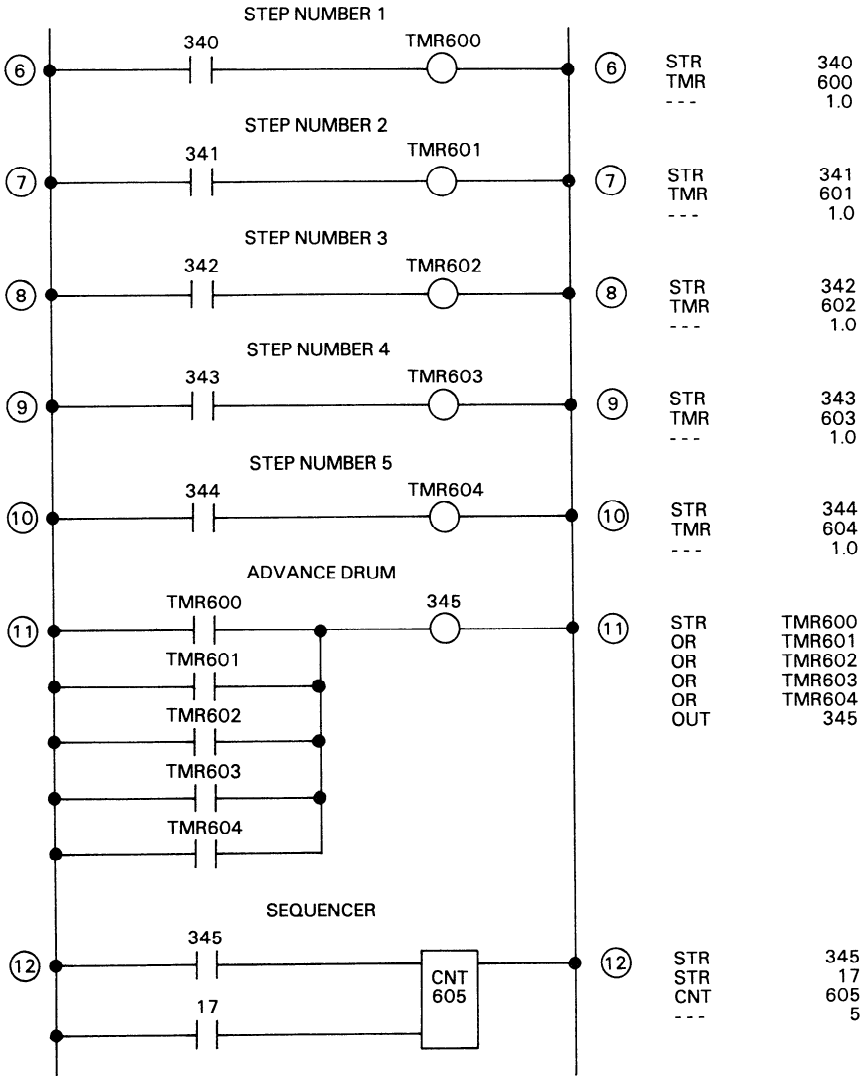

Figure 8.5 (Continued)

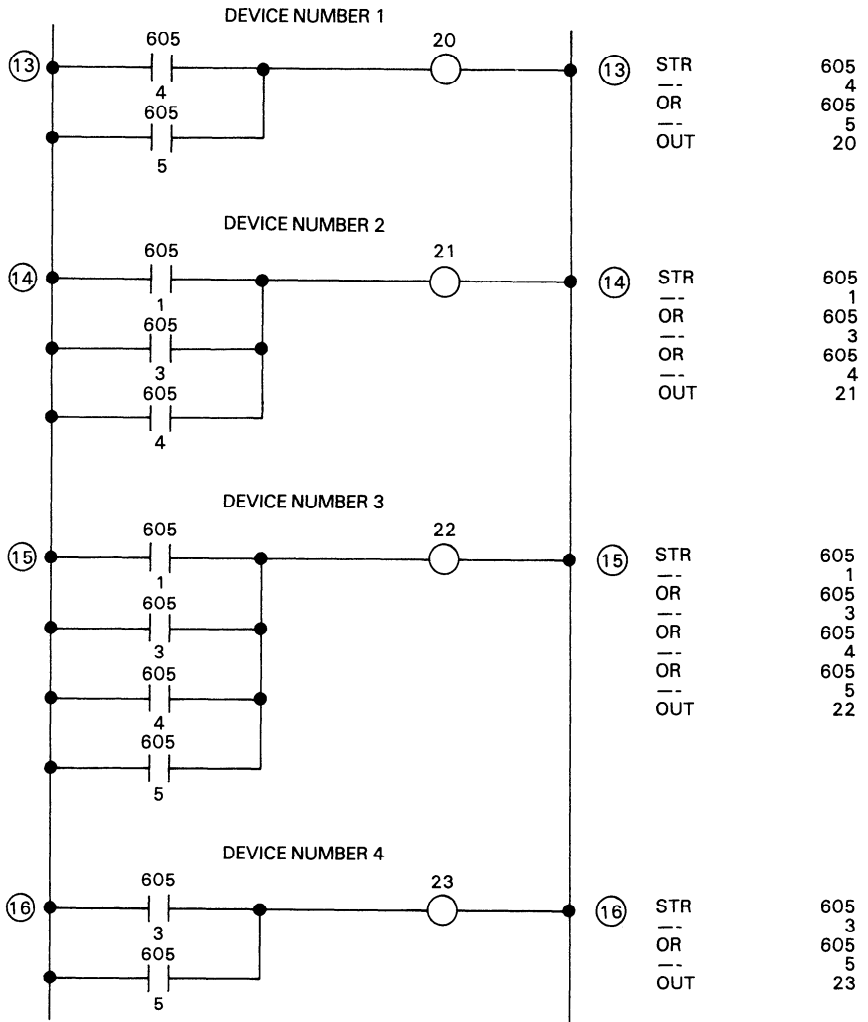

Figure 8.5 (Continued)

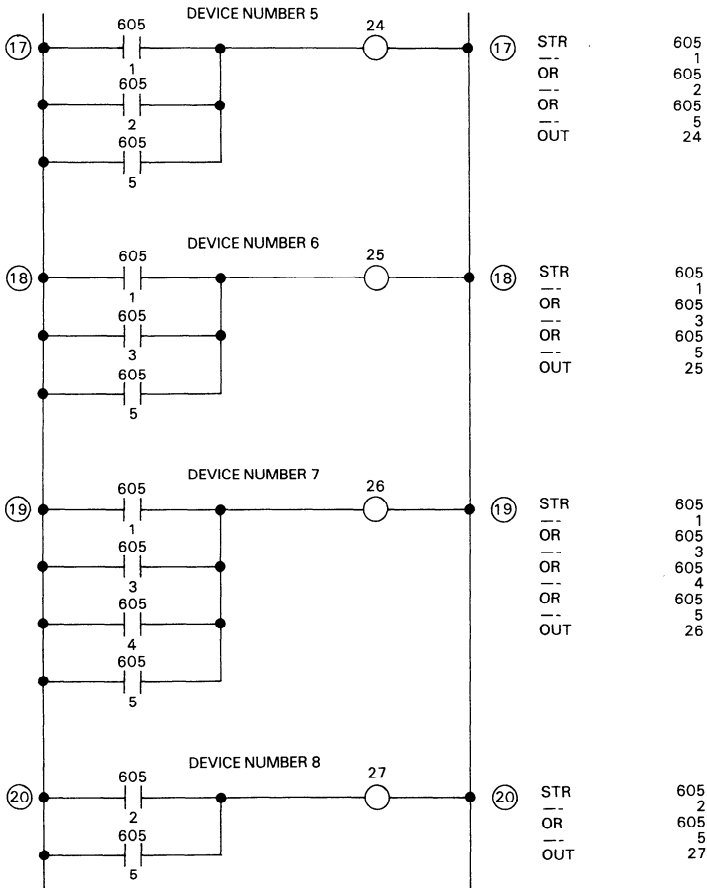

Figure 8.5 (Continued)

APPLICATION 4 — CASCADED COUNTERS

If an application requires a counter with presets greater than 9999, multiple counters can be assigned to that function. Two counters can record values up to 99,999,999 and three up to 999,999,999,999 etc. Additional logic is incorporated to generate a reset signal at 10,000 counts instead of the normal 9999.

The following logic uses two counters to record up to 99,999,999 events. Counter 601 records the low order values (thousands, hundreds, tens, and units) and counter 602 the high order values (tens of millions, millions, hundreds of thousands, tens of thousands).

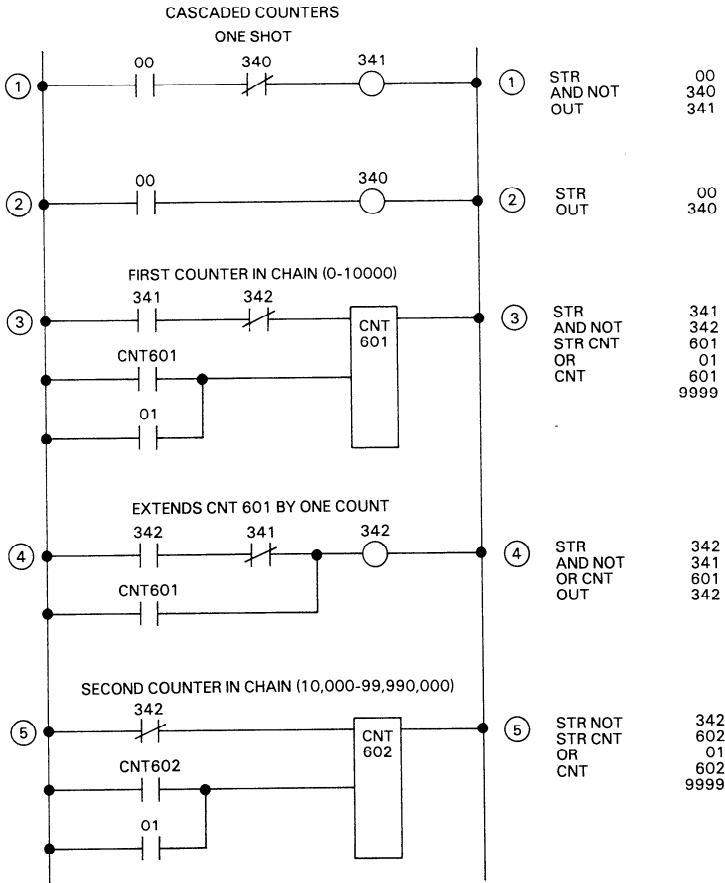

Figure 8.6 SAMPLE CASCADED COUNTER LOGIC

APPLICATION 5 — COIL 374, POWER-UP ONE-SHOT

In industry, power loss to machines and process equipment is a frequent event. When such an event occurs it creates havoc with automatically controlled equipment and processes. The moment power returns it may be desirable to place the machine or process in a “hold” state until verification or critical limits, position of moving parts, and support equipment interfaces are confirmed to be correct by authorized personnel.

DESCRIPTION OF OPERATION

The Series One Junior has a special function reference (internal coil 374) that provides a pulse during the first scan only after powering up the CPU or going from program to run mode. Using this pulse in the ladder logic, as shown below, will place the machine or process in the desired hold state.

The instant power returns to an automatic machine or process, certain phases (for instance, activating a cylinder, starting a motor etc.) of the automatic cycle need to be inhibited until a correct state is determined allowing the continuation of the cycle.

The following program scheme will inhibit those critical outputs from activating field devices until a reset pushbutton is depressed, thereby, releasing all inhibited outputs and allowing the cycle to continue.

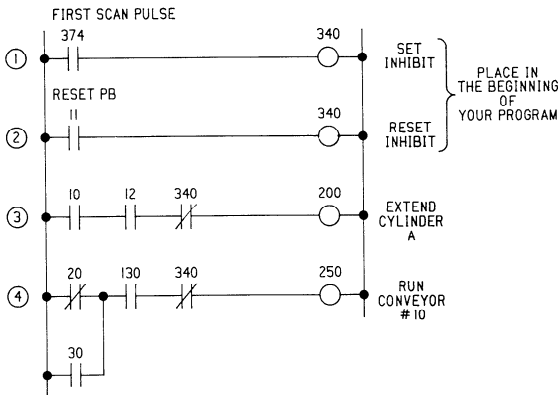

Figure 8.7 TYPICAL MACHINE OR PROCESS POWER-UP INHIBIT LOGIC

The program logic in the above figure is an example you can use to inhibit certain phases of a cycle. In this example, when power returns to the process, 374 will be on during the first scan of the CPU, latching coil 340 on. The referenced NC contact of coil 340 is placed in series with the logic that actuates output coils 200 and 250. Even if the program logic is calling for coils 200 and 250 to turn on, they will not until 340 is unlatched. The only way to unlatch 340 is to depress the reset pushbutton (11), allowing outputs 200 and 250 to be turned on.

APPLICATION 6 — COIL 375, 10HZ CLOCK

The Series One Junior PC has a special function reference that continuously provides a pulse every tenth of a second. The following two examples use the function of this reference (10 Hz Internal Coil 375) to create a cumulative timer and a time of day clock.

EXAMPLE 1 — CUMULATIVE TIMER

In this example, when reference 01 is on, time (in tenths of a second) would be accumulated by counter 600. If the time to be measured is anticipated to be larger than 999.9 seconds, cascading another counter will increase the range to 9,999,999.9 seconds. This technique allows you to measure the duration of an intermittent event that would otherwise reset the standard timer when changing state.

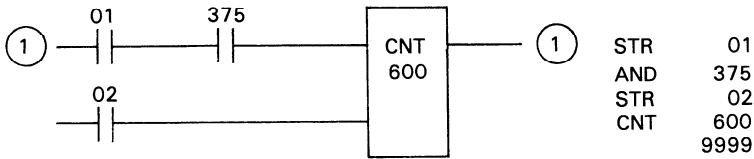

Figure 8.8 CUMULATIVE TIMER

EXAMPLE 2 — TIME OF DAY CLOCK

In this example, the 10HZ clock (Internal Coil 375) is used to program a time of day clock with reset capabilities. This is a 24-hour time clock, with the time format being XX:YY, where XX = hours (0-23) and YY = minutes (0-59). The 10HZ clock provides the 0.1 second pulse to counter 603 which in turn produces one pulse every second. The remaining three counters, 600, 601 and 602 keep track of seconds, minutes and hours that have elapsed. If power goes off and the clock needs resetting, the combined use of a 3 position switch and a pushbutton, as shown in Figure 8.10, will allow you to set the correct time. The lower portion of Figure 8.10 is the ladder logic which resets the clock. An I/O Simulator module, IC610MDL124, could also be used and programmed to reset the clock).

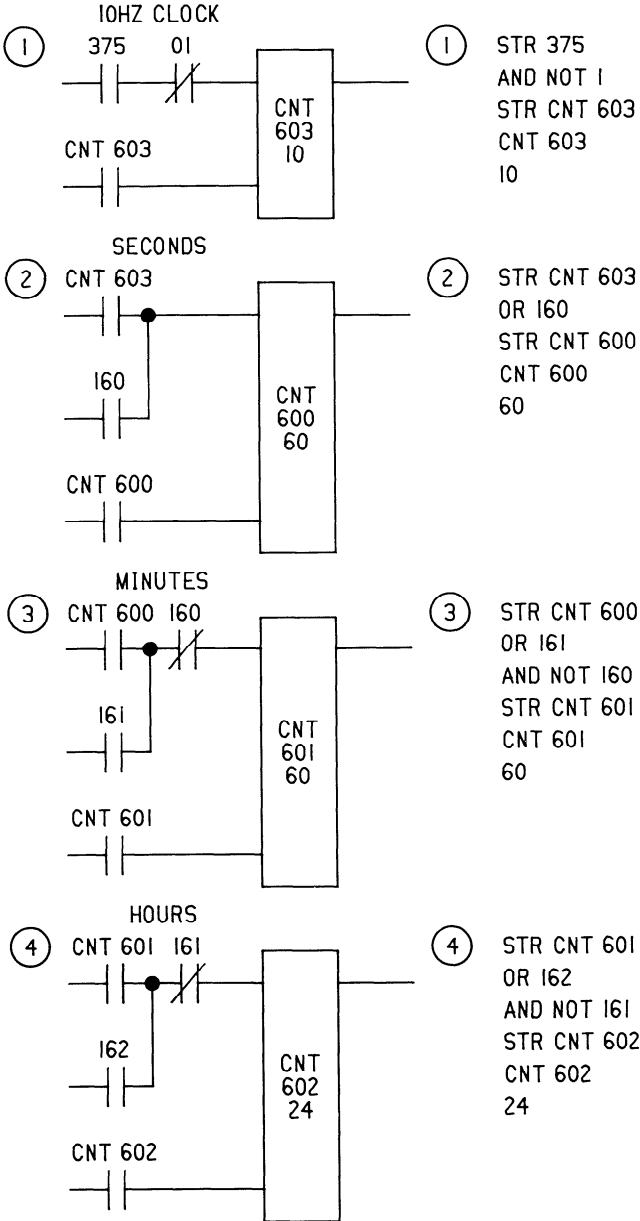
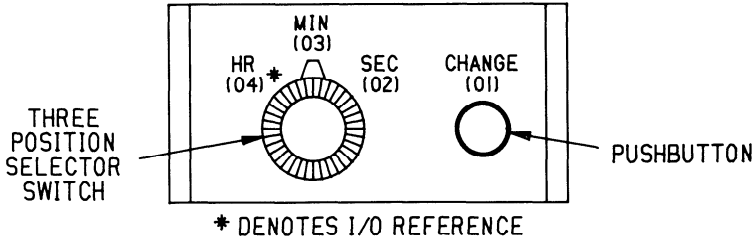

Figure 8.9 SAMPLE 24 HOUR TIME CLOCK LOGIC



LADDER LOGIC

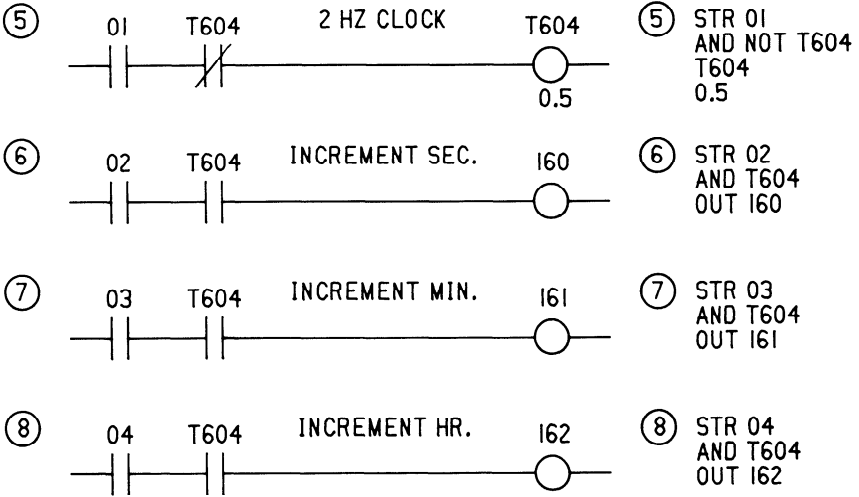

Figure 8.10 TIME CLOCK RESETTING

To reset the time, use the following procedure.

1. Select hours, minutes or seconds with the 3 position selector switch.
2. Monitor the appropriate counter.

CNT 600: Seconds

CNT 601: Minutes

CNT 602: Hours

Keystroke sequence is SHF, 6XX, MON

3. Depress the change button until the proper value (time) is displayed on the programmer.

APPLICATION 7 — START/STOP CIRCUIT

A simple but informative application for the Fast Response module is the Start/Stop circuit. In this example, Output 4 is in the Fast Response mode and is controlled by Inputs 0 and No. 1. The timing diagram shows worst case response times.

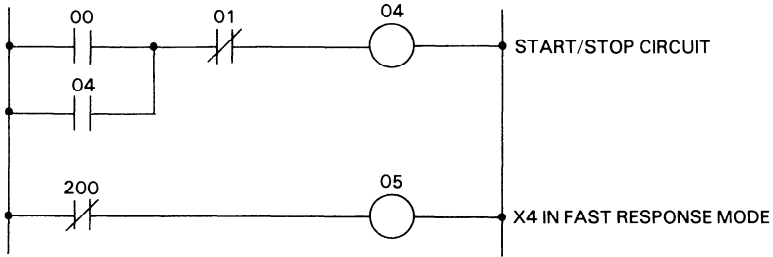

Figure 8.11 FAST RESPONSE START/STOP LOGIC

I/O REFERENCE	DEFINITION
00	Enable output, X4 in fast response mode
01	Disable output X4 in fast response mode
04	Output X4 tied to field device being controlled
05	Mode select for output X4 DISABLED: manual mode ENABLED: fast response mode
200	Dummy contact to put output X4 in fast response mode

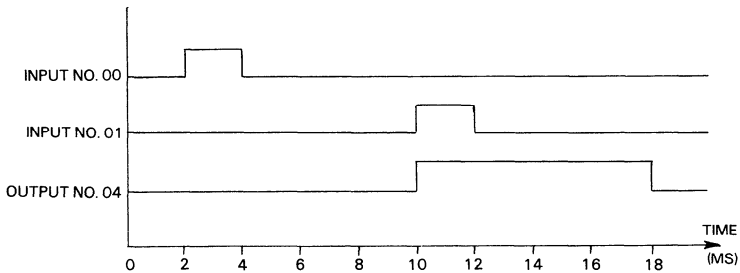

Figure 8.12 WORST CASE TIMING DIAGRAM

APPLICATION 8 — USING AND-STR, OR-STR INSTRUCTIONS

The Series One Junior, Series One and Series Three PCs solve rungs of ladder logic, that includes groups of contacts in series or parallel, through the use of a push down stack. The push down stack has eight storage locations where an ON or OFF (1 or 0) condition is stored, as shown in Figure 8.13.

PUSH DOWN STACK

ON (1)	LOCATION NUMBER 1
ON (1)	LOCATION NUMBER 2
OFF (0)	LOCATION NUMBER 3
ON (1)	LOCATION NUMBER 4
OFF (0)	LOCATION NUMBER 5
OFF (0)	LOCATION NUMBER 6
ON (1)	LOCATION NUMBER 7
OFF (0)	LOCATION NUMBER 8

Figure 8.13 PUSH DOWN STACK STORAGE LOCATIONS

DESCRIPTION OF OPERATION

There are four basic rules which govern operation of the stack (refer to Examples 1 and 2).

Rule Number 1

A STR X instruction pushes the contents of each position in the stack down one location. The contents of location number 1 is pushed down to location number 2, the contents of location number 2 is pushed down to location number 3 etc. The logical status of reference X is then moved into location number 1 of the stack.

Rule Number 2

The AND Y or OR Y instruction logically ANDs or ORs the status of reference Y (ON/OFF) with the ON/OFF status of location number 1 in the stack, and writes the result back into location number 1.

Table 8.1 AND Y and OR Y TRUTH TABLES

AND (Series)

BEFORE		AFTER
Y	LOCATION NUMBER 1	LOCATION NUMBER 1
OFF	OFF	OFF
ON	OFF	OFF
OFF	ON	OFF
ON	ON	ON

OR (Parallel)

BEFORE		AFTER
Y	LOCATION NUMBER 1	LOCATION NUMBER 1
OFF	OFF	OFF
ON	OFF	ON
OFF	ON	ON
ON	ON	ON

Rule Number 3

The AND STR or OR STR instruction logically ANDs or ORs location number 1 in the stack with location number 2 and writes the result into location number 1. In other words these instructions put one group of contacts in series or parallel with another group of contacts. This instruction also moves the contents of positions 3 thru 8 up one location.

Rule Number 4

An OUT Y instruction sets Y to reflect the status of location number 1 in the stack. If the status of location number 1 is on (1), output Y will be turned on. If the status of position 1 is OFF (0) output Y will be turned OFF.

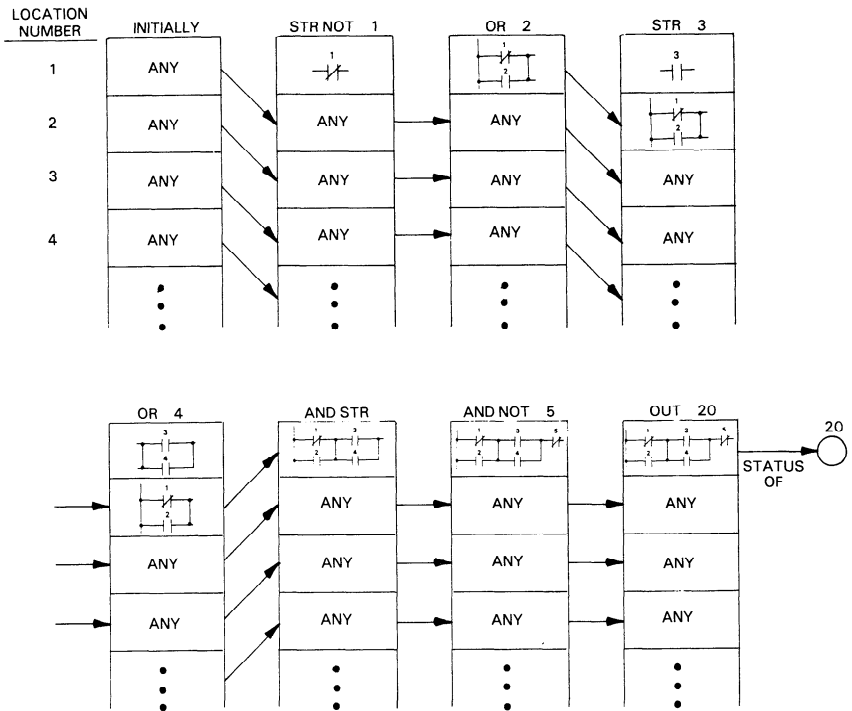
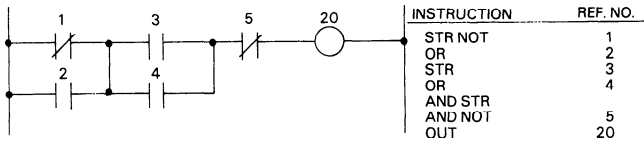

Figure 8.14 AND STR/OR STR EXAMPLE 1

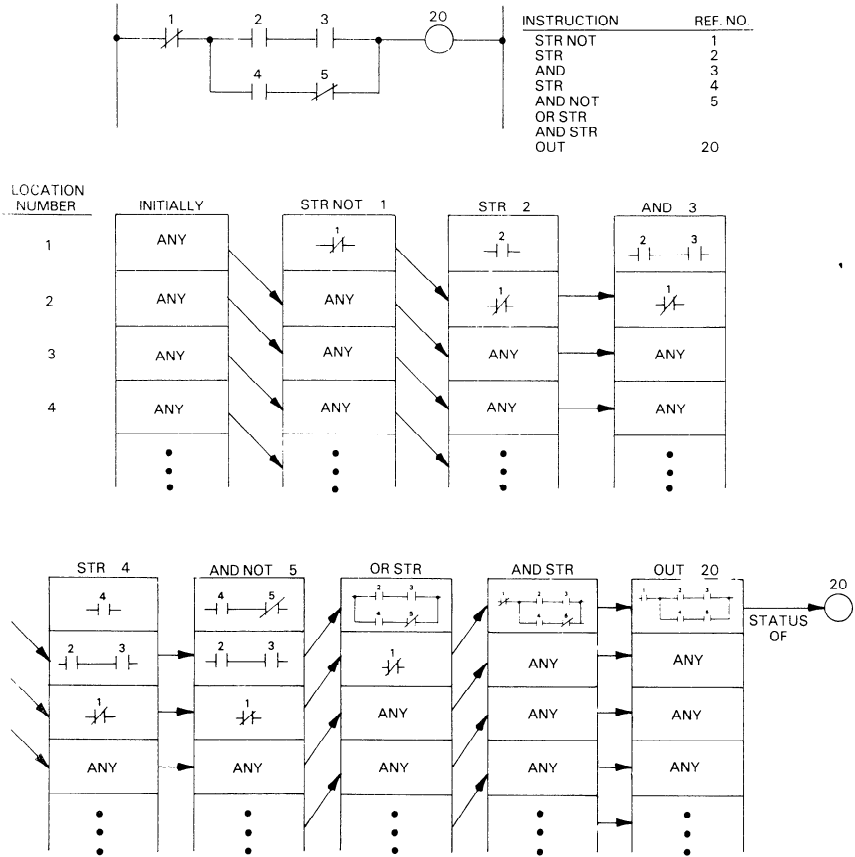

Figure 8.15 AND STR/OR STR EXAMPLE 2

APPENDIX A GLOSSARY OF TERMS

Address — A series of decimal numbers from 0 to 700 in the Series One Junior, assigned to specific program memory locations and used to access those locations.

AND — An operation that places two contacts or groups of contacts in series. Both control the resultant status.

BCD (Binary Coded Decimal) — A 4-bit system in which individual decimal digits (0 through 9) are represented by 4-bit binary numerals; e.g., the number 43 is represented by 0100(4) 0011(3) in the BCD notation.

Bit — The smallest unit of memory. Can be used to store only one piece of information that has two states (for example, a One/Zero, On/Off, Good/Bad, Yes/No, etc). Data that requires more than two states (e.g. numerical values 000-999) will require multiple bits.

CMOS — A read/write memory that requires a battery in order to retain its content upon loss of power.

CPU (Central Processing Unit) — The central device or controller that interprets user instructions, makes decisions and executes the functions based on a stored program. This program specifies actions to be taken to all possible inputs.

Counter — A function within the PC that records events based upon the On/Off transition of a signal. A coil associated with the counter is energized at a user determined preset value.

Field Devices — User supplied devices typically providing information to the PC (Inputs: pushbutton, limit switches, relay contacts, etc.) or performing PC tasks (Outputs: motor starters, solenoids, indicator lights, etc.).

Group — A series of eight consecutive I/O points, internal coils, etc.

Inputs — A signal, typically ON or OFF, that provides information to the PC.

I/O (Input/Output) — That portion of the PC to which field devices are connected. Isolates the CPU from electrical noise.

I/O Scan — A method by which the CPU monitors all inputs and controls all outputs within a prescribed time.

K — An abbreviation for kilo or exactly 1024 in the world of computers. Usually related to 1024 words of memory.

Ladder Diagram — A representation of control logic relay systems. The user programmed logic is expressed in relay equivalent symbology.

Latch — A PC operation that causes a coil to stay on and remain on even if power or the input is removed. Referred to as a retentive function.

Logic — A fixed set of responses (outputs) to various external conditions (inputs). All possible situations for both synchronous and non-synchronous activity must be specified by the user. Also referred to as the program.

Memory — A physical place to store information such as programs and/or data.

Microsecond (μ s) — One millionth of a second. 1×10^{-6} or 0.000001 second.

Millisecond (ms) — One thousandth of a second. 1×10^{-3} or 0.001 second.

Modules — A replaceable electronic subassembly usually plugged in and secured in place but easily removable in case of fault or system redesign.

Noise — Undesirable electrical disturbances to normal signals generally of high frequency content.

Non-Retentive Coil — A coil that will go off when power is removed.

Optical Isolation — Use of a solid state device to isolate the user input and output devices from internal circuitry of an I/O module and the CPU.

OR — An operation that places two contacts or groups of contacts in parallel. Either can control the resultant status.

Outputs — A signal typically ON or OFF, originating from the PC with user supplied power, that controls external devices based upon commands from the CPU.

PC — See Programmable Controller.

Peripheral Equipment — External units that can communicate with a PC; e.g., cassette tape recorder, printer or PROM writer.

Preset — A numerical value specified in a function which establishes a limit for a counter or timer. A coil will energize when this value is reached.

Program — A sequence of functions entered into a Programmable Controller to be executed by the CPU for the purpose of controlling a machine or process.

Programmable Controller — A solid-state industrial control device which receives inputs from user supplied control devices such as switches and sensors, implements them in a precise pattern determined by ladder diagram based programs stored in the user memory, and provides outputs for control of user supplied devices such as relays and motor starters.

Programmer — A device for entry, examination and alteration of the PC's memory including logic and storage areas.

PROM — A read only memory that requires a special method of loading and is retentive upon power loss.

RAM — An acronym for Random Access Memory. A solid-state memory that allows individual bits to be stored and accessed. This type of memory is volatile; that is, stored data is lost under no power conditions, therefore a battery backup is required.

Read — To have data entered into a PC from a peripheral unit.

Reference — A number used in a program that tells the CPU where data is coming from or where to transfer the data.

Retentive Coil — A coil that will remain in its last state, even though power has been removed.

Rung — A sequence or grouping of PC functions that control one coil. One or more rungs form a ladder diagram.

Scan — The technique of examining or solving all logic steps specified by the program in a sequential order from the first step to the last.

Thumbwheel Switch — A rotating numeric switch which can be used for inputting numeric data to a PC.

Unlatch — A PC function that causes an output previously turned on by a latch function to turn off no matter how briefly the function is enabled.

Word — A measurement of memory. In the Series One Junior, one word is equal to 16 bits.

Write — To output or transfer data from the PC to a peripheral unit.

APPENDIX B OTHER PROGRAMMABLE CONTROLLERS

SERIES ONE™ PROGRAMMABLE CONTROLLER

The Series One Programmable Controller is a low-cost compact PC designed to replace 4 to 100 relays and any combination of up to 64 timers, counters, and sequencers. Its small mounting area of 54 square inches (348 sq. cm) allows 32 I/O in the same space as four 4 pole relays. It is expandable from 4 to 112 I/O points in groups of 4, 8, or 16 circuits. Either CMOS RAM with battery back-up or EPROM memory can be selected for program storage and is available with 700 words (CMOS), expandable to 1724 words (CMOS or EPROM).

Modular plug-in construction allows any module to be easily changed without disturbing any other part of the PC.

The Series One PC can be programmed by one of three methods. A hand-held programmer can be mounted on the base unit with the CPU or can be easily removed and carried to the PC as needed. The hand-held programmer also allows monitoring of logic, timer and counter values and I/O points.

The second method of programming the Series One is with the LCD Portable Programmer which also allows ladder diagram programming. The Portable Programmer uses a liquid crystal display (LCD) screen so that the ladder logic rungs may be displayed as they are entered. The program can be documented using a standard parallel or Centronics compatible printer.

The third method of programming the Series One PC is with a Workmaster® Industrial computer using Logicmaster™ 1 application software. Programming with Logicmaster software allows entering and editing programs, printing those programs, and annotating programs. Annotation can include nicknames and names for program elements, labels for coils and explanation of program rungs or segments.

Table B.1 SERIES ONE CAPABILITIES

I/O Points	112 total
Internal Coils	144 total
Non-Retentive	112
Retentive Coils	28
Initial Reset	1
0.1 Second Clock	1
Disable All Outputs	1
Back-Up Battery Status	1
Shift Registers	128 steps
Timer/Counters	64 (1)
Sequencers	64 (1000 steps)

- (1). Maximum total number of Timers and Counters or a combination of Timers and Counters.

SERIES ONE I/O MODULES

Following is a list of I/O modules that are available for the Series One family and can be used with any of those PCs, including Series One Junior, Series One and Series One Plus.

Table B.2 SERIES ONE I/O MODULES

MODULE NAME	I/O POINTS
24 V dc Sink Input	8
24 V dc Sink Input	16
24 V dc Sink Load Input	16
24 V ac/dc Source Input	8
24 V ac/dc Source Input	16
115 V ac Input	8
115 V ac Isolated AC Input	4
115 V ac Input (UL)	6
230 V ac Input	8
Analog Input	4 Channels
24 V dc Sink Output	8
24 V dc Sink Output	16
24 V dc, 2 A, Sink Output	4
24 V dc, 2 A, Sink/Source Output	4
24 V dc Source Output	8
24 V dc Source Output	16
24 V dc Input/Output	4/4
24 V dc Input/Relay Output	4/4
115/230 V ac Output	8
115/230 V ac Isolated Output	4
115 V ac Output (UL)	6
Relay Output	8
Relay Output	16
Relay Output (UL)	5
Analog Output	2 Channels
Fast Response I/O	4/2
High Speed Counter (1)	
Thumbwheel Interface (1, 3)	
I/O Simulator	8
Timer/Counter Setpoint Unit (2, 3)	

- (1). Cannot be used with Series One Junior.
- (2). Cannot be used with Series One.
- (3). Use one or the other in a Series One Plus, both cannot be used at the same time.

SERIES ONE™ PLUS PROGRAMMABLE CONTROLLER

The Series One Plus programmable controller offers all of the features and functions of the Series One programmable controller, plus several enhancements. These enhancements include more I/O, an expanded instruction set, accelerated data communications, full analog I/O capability, 16-bit data registers and password protection.

The total number of I/O points available with a Series One Plus is 168. The instruction set includes data operations, which are similar to the Series Three instructions, in addition to all of the functions of the Series One. The data operations include data moves, logical operations, conversion, external fault diagnosis, and math functions.

Data communications, through the optional Communications Control Module, is faster than with a Series One PC. This reduces program upload/download time and access time to I/O register and timer and counter data. The data registers allow data storage for manipulation with data instructions. Timer and Counter presets can also be stored in the registers for use as required.

The Series One Plus can be programmed using the hand-held programmer or with the LCD Portable Programmer. Programming with the Workmaster Industrial computer is a future option with this PC.

A unique 4-digit password may be entered by the user, which gives the capability of preventing unauthorized users or inadvertent access to the user program. Most functions are disabled when a password is in effect. To gain access to all programmer functions, when a password is invoked, a log on/off sequence must be entered.

Table B.3 SERIES ONE PLUS CAPABILITIES

I/O Points	168 total
Internal Coils	144 total
Non-Retentive	112
Retentive Coils	28
Initial Reset	1
0.1 Second Clock	1
Disable All Outputs	1
Back-Up Battery Status	1
Shift Registers	128 steps
Timer/Counters	64 (1)
Sequencers	64 (1000 steps)
Data Registers	64 (16-bit)

- (1). Maximum total number of Timers and Counters or a combination of Timers and Counters.

SERIES THREE™ PROGRAMMABLE CONTROLLER

The Series Three PC is the next larger programmable controller, relative to the physical size of the Series One PC. It provides a compact controller capable of handling applications in the 16 to 400 I/O range. It offers many of the same outstanding features as the Series One and Series One Plus, such as compact size, CMOS or PROM memory, hand-held programmer, programming with the LCD portable programmer or programming with the Workmaster industrial computer, using Logicmaster 3 software. Improved capabilities include 4K user memory and 400 I/O points. It also offers four function arithmetic, as does the Series One Plus. A Series Three PC can communicate I/O information over a remote communications link via a twisted-pair or a fiber optic link. The following table lists specifications for the Series Three PC.

Table B.4 SERIES THREE PC SPECIFICATIONS

Size for CPU and 128 I/O (W × H × D)	18.9" × 10.3" × 6.3" (480mm × 262mm × 159mm)
Functions	Relay, including Latches Timers (1.0, 0.1 Sec) Counters Master Control Relay Shift Registers Add, Subtract, Compare Multiply, Divide Data Moves Subroutines
Scan Rate	20 msec for 2K words 40 msec for 4K words
Internal References	400 I/O 64 Latches 304 Internal Coils 128 Shift Register Stages 128 Timer/Counters (4-digit)
Programmer	Built-In with Keylock Portable Programmer Workmaster (Logicmaster 3)

AVAILABLE I/O TYPES

INPUT MODULES	CIRCUITS	OUTPUT MODULES	CIRCUITS
115 V ac	16	115/230 V ac, 2 A	16
Isolated 115 V ac	8	Isolated 115/230 V ac, 2 A	8
24 V dc Sink	16	24 V dc (1 A)	16
24 V ac/dc Source	16	24 V dc (2 A)	8
230 V ac	16	Relay	16
Analog	2	Analog	2

OTHER MODULES

High Speed Counter, I/O Link Local and Remote (Twisted pair and Fiber Optic)

SERIES SIX™ PROGRAMMABLE CONTROLLERS

The Series Six family of programmable controllers consists of three models: 60, 600, 6000. Each model also has internal register storage in varying sizes. The family concept allows the use of common features between models. The common features include a common programming language featuring a basic, extended, and advanced set, the same reference numbers, the same Workmaster® Industrial computer for programming and running many available programs tailored for industrial applications, the same I/O structure; including modules, racks and cables, most of the same CPU modules, transportable programs from one model or size to another (upward or downward compatibility) and the same options.

Table B.5 SERIES SIX CPU CAPACITIES

MODEL	LOGIC MEMORY	I/O CAPACITY		REGISTER STORAGE
		INPUTS	OUTPUTS	
60	2K	256	256	256
60	4K	1000	1000	1024
600	8K	1000	1000	1024
600	8K	1000	1000	8192
6000	32K	2000	2000	8192

Programming Series Six PCs

Programs are entered with the Workmaster Industrial computer, using the Logic-Master™ 6 software package, or with the Program Development Terminal. The Workmaster has a 9" CRT display, a full-travel keyboard, integral 3½" diskette drive, and full off-line/stand alone programming. The programming functions are available in 3 versions, Basic, Advanced and Expanded, with each successive version offering more capability. The Basic programming function set is basically a relay ladder diagram language consisting of relay ladder logic (N.O. and N.C. contacts, counters, timers, one-shots and latches). Additional features in the Basic group include Arithmetic (add, subtract, and compare), data moves, binary and BCD conversion, a Master Control Relay function and communication requests. The Advanced Mnemonic group includes the following functions:

- Data Moves (Left 8, Right 8, Block)
- Signed Arithmetic (Double Precision Add and Subtract, Extended Add and Subtract, Multiply, Divide and Greater Than)
- Table Moves (Table-To-Destination, Source-To-Table, Move Table and Move Table Extended)
- List (Add-To-Top, Remove-From-Bottom, Remove-From-Top and Sort)
- Matrix (AND, OR, Exclusive OR, Invert and Compare)
- Bit Matrix (Bit Set, Bit Clear, Shift Right, Shift Left)
- Control (Do Subroutine, Return, Suspend I/O, Do I/O and Status)

The Advanced functions also add an additional Table Move instruction, Move Table Ex, which has the ability to address all 8192 registers in an advanced model 600 or a model 6000. The enhanced functions available with the Expanded function set are listed under the description of the Series Six Plus PC.

I/O Modules for Series Six PCs

I/O modules available for the Series Six PCs include the following:

- 115/230 V ac/dc, Inputs and Outputs
- 115/230 V ac Isolated Inputs and Outputs
- 12 V ac/dc Inputs
- 24-48 V ac/dc Inputs
- 12, 24, 48 V dc Sink and Source Outputs
- 120 V dc Outputs
- High Density Inputs (32 Inputs)
- High Density Outputs (32 Outputs)
- Reed Relay Outputs
- Analog Inputs and Outputs
- Thermocouple Inputs
- Interrupt Inputs
- Axis Positioning, Type 1 and Type 2
- High Speed Counter
- ASCII BASIC module, 12K or 20K versions
- I/O Receiver and Transmitter for operation up to 2000 feet (600 meters).
- Remote I/O Driver and Receiver for cable operation up to 10,000 feet (3 Km) or unlimited distance over a modem link.

OPTIONAL ITEMS

Optional items for use with a Series Six PC include a Redundant Processor Unit (RPU), Communications Control Modules, an Operator Interface Unit (OIU), color and amber Operator Interface Terminals (OIT), ProLoop™ process controllers, and various software packages for use with the Workmaster information center. Software packages include VuMaster™, FactoryMaster™, and ProcessMaster™. Additional software packages will be available in the future.

The RPU acts as a switch to transfer control from one Series Six CPU or I/O chain to a standby in the event that a failure occurs in the first. This provides a method of minimizing downtime in the event of a failure in the PC system.

—The Type 2 Communications Control Module (CCM) provides 2 independent ports (RS-232C, RS-422, or 20 mA) for slave communications with computers or similar intelligent devices. The Type 2 CCM also has the added function of originating communications to other Series Six CPUs, computers, or other similar intelligent devices from the user's ladder diagram program. The Type 3 CCM also provides 2 ports, and the protocol required for interfacing to selected process control systems.

The OIU is a hand-held micro-terminal that allows an operator to monitor or modify the register contents and I/O states of a Series Six CPU. The OIU communicates with a CPU through the Communications Control module (Type 2).

The OIT connects to the Series Six through an ASCII/BASIC module and provides CRT background screens for the display of status from the CPU. User configuration of the screens allows tailoring the screens to fit the application.

The ProLoop process controllers are a group of analog controllers that can operate independent of, but be supervised by a Series Six PC.

SERIES SIX™ PLUS PROGRAMMABLE CONTROLLER

The Series Six Plus PC, an extension of the Series Six family, is a new cost effective programmable controller that can be easily expanded to cover a wide variety of applications. The Series Six Plus PC offers in one rack, more compatibility than the Series Six family of programmable controllers, which includes models 60, 600 and 6000.

A Combined Memory module, including internal memory, up to 32K words of user memory and up to 16K of register memory, is available in six different configurations as shown below.

Table B.6 SERIES SIX PLUS COMBINED MEMORY CONFIGURATIONS

Total Memory	User Memory	Register Memory
5K	4K	1K
12K	4K	8K
16K	8K	8K
24K	16K	8K
32K	16K	16K
48K	32K	16K

The Series Six Plus PC can be configured to have up to 16K Inputs and 16K Outputs. Instruction sets for programming are available in 3 versions; Basic, Advanced and Expanded. The Expanded function set has all of the functions of the Basic and Advanced function sets, plus several new instructions and enhancements which include:

- Reference range expanded for 16K I/O
- Enhanced DO I/O and STATUS instructions
- New WINDOW function
- Floating Point functions, including:
 - Add, subtract, multiply, divide, greater than
 - Integer to floating point
 - Floating point to integer

The Series Six Plus PC also includes enhanced GENIUS™ I/O diagnostics. The CPU rack, which contains all required CPU modules, has 6 slots available for I/O modules. This allows a CPU rack to contain up to 192 I/O points using High Density modules.

The Series Six Plus PC is compatible with all existing Series Six I/O modules, peripherals and software packages. Programs are entered with the Workmaster® Industrial computer, using Logicmaster™ 6 software, as with the other models of the Series Six family of PCs.

INDEX

5-slot rack	1-4, 2-8, 2-10
5-slot rack (UL Listed)	6-89
10-slot rack	1-4, 2-8, 2-10
115 V ac Input /115/230 V ac Output, Basic Unit	6-5
specifications, input	6-5
wiring, input	6-6
specifications, output	6-7
wiring, output	6-8
115 V ac Input module	6-25
sample input circuit	6-26
specifications	6-25
wiring	6-26
115 V ac Isolated Input module	6-29
sample input circuit	6-30
specifications	6-29
wiring	6-30
115/230 V ac Isolated Output module	6-39
I/O points vs temperature chart	6-39
specifications	6-39
wiring	6-40
sample output circuit	6-40
115/230 V ac Output module	6-37
I/O points vs temperature chart	6-37
sample output circuit	6-38
specifications	6-37
wiring	6-38
16 circuit I/O modules	2-1, 6-3
230 V ac Input module	6-27
sample input circuit	6-28
specifications	6-27
wiring	6-28
24 V ac/dc Source Input module	6-35
sample input circuit	6-36
specifications	6-35
wiring	6-36
24 V ac/dc Source Input, w/Rem Term Board	6-98
24 V dc 2 Amp Sink Output module	6-45
I/O points vs temperature chart	6-45
sample output circuit	6-46
specifications	6-45
wiring	6-46
24 V dc 2 Amp Sink/Source Output module	6-47
I/O points vs temperature chart	6-47
sample output circuit	6-48
specifications	6-47
wiring	6-48
24 V dc Input/Output (4 In/4 Out) module	6-53
input circuit	6-54
output circuit	6-54
wiring	6-54
specifications	6-53

24 V dc Input/Relay Output (4 In/4 Out) module	6-55
maximum current vs load	6-56
sample input circuit	6-57
sample output circuit	6-57
specifications	6-55
wiring	6-56
24 V dc Sink In — 115/230 V ac Out, Basic Unit	6-9
specifications, input	6-9
wiring, input	6-10
specifications, output	6-11
wiring, output	6-12
24 V dc Sink Load Input, w/Rem Term Board	6-96
24 V dc Sink Input (16 circuits) module	6-33
I/O points vs temperature chart	6-33
specifications	6-33
sample input circuit	6-34
wiring	6-34
24 V dc Sink Input (8 circuits) module	6-31
sample input circuit	6-32
specifications	6-31
wiring	6-32
24 V dc Sink Input/Output, Basic Unit	6-13
specifications, input	6-13
wiring, input	6-14
specifications, output	6-15
wiring, output	6-16
24 V dc Sink Input/Output, Expansion Unit	6-65
24 V dc Sink Input/Relay Output Basic Unit	6-17
specifications, input	6-17
specifications, output	6-19
wiring, input	6-18
wiring, output	6-20
24 V dc Sink Input/Relay Output, Expansion Unit	6-67
24 V dc Sink Output (16 circuits) module	6-43
I/O points vs temperature chart	6-43
specifications	6-43
sample output circuit	6-44
wiring	6-44
24 V dc Sink Output (8 circuits) module	6-41
I/O points vs temperature chart	6-41
sample output circuit	6-42
specifications	6-41
wiring	6-42
24 V dc Sink Output, w/Rem Term Board	6-100
24 V dc Source Input/Relay Output Basic Unit	6-21
specifications, input	6-21
wiring, input	6-22
specifications, output	6-23
wiring, output	6-24
24 V dc Source Input/Relay Output, Expansion Unit	6-70
24 V dc Source Output module	6-49
I/O points vs temperature chart	6-49

sample output circuit	6-50
specifications	6-50
wiring	6-50
24 V dc Source Output, w/Rem Term Board	6-102
AND•STR and OR•STR connections	5-13
Alter one logic element	4-14
Analog Input Module	6-73
Analog Output Module	6-78
Appendix A, glossary of terms	A-1
Appendix B, other programmable controllers	B-1
Series One	B-1
Series Six	B-3
Series Three	B-2
Application 1, one-shots	8-1
Application 2, flip-flop	8-2
Application 3, event/time drum	8-3
Application 4, cascaded counters	8-7
Application 5, coil 374, power-up one-shot	8-8
description of operation	8-8
Application 6, coil 375, 10 hz clock	8-9
example 1 — cumulative timer	8-9
example 2 — time of day clock	8-9
sample 24 hour time clock logic	8-10
time clock resetting	8-11
Application 7 fast response start/stop logic	8-12
start/stop circuit	8-12
Application 8, using AND•STR, OR•STR instructions	8-13
AND•STR/OR•STR example 1	8-15
AND•STR/OR•STR example 2	8-16
AND Y and OR Y truth tables	8-14
description of operation	8-13
Auxiliary port, see tape port	2-6
Back-up battery location	7-6
Basic unit field wiring	6-1
Battery compartment access cover	2-5
Bleeder resistor calculation	6-11
Bleeder resistor, typical connection	6-15
CCM2, see communications control module	2-12
CPU operating principles	5-3
CPU scanning	5-3
CPU scanning, illustration of	5-4
CPU	1-5
Cable, expansion	2-1
Catalog Numbers	2-2
Catalog numbers, table of	6-4
Chapter 1, introduction	1-1
Chapter 2, physical equipment	2-1
Chapter 3, installation	3-1
Chapter 4, operation	4-1
Chapter 5, programming	5-1
Chapter 6, I/O capabilities	6-1
Chapter 7, maintenance	7-1
Chapter 8, applications	8-1
Clear all memory	4-15, 5-9

Communicating with other devices	1-7
Communications control module	2-12
Component replacement	7-3
Connector, front panel	2-4
Counter references	5-2
Counters, logic example	5-23
Counters, logic requirements	5-22
Counters, programming of	5-22
Data communications unit	1-3, 2-12
Delete one logic element	4-15
Developing the program	5-7
Disabling outputs	5-18
Display a specific address	4-17
Editing keys, use of	4-5
Entering a rung with parallel contacts	5-9
Entering a rung with series contacts	5-8
Entering a simple timer rung	5-10
Equipment configuration, physical	2-1
Error code definitions	4-9, 4-10, 4-11
Error codes, program	4-8
Expansion cable	2-1
Expansion rack	1-2, 2-10
grounding	3-4
heat dissipation	2-11
module insertion	3-7
module removal	3-7
mounting considerations	2-11
terminal strip	3-6
Expansion units, installation of	3-13
Expansion requirements, I/O	2-8
Extended timers and counters, example of	5-24
Extender cable, programmer	3-8
Extender cable, pull tab	3-8, 3-9
Fast Response I/O module	6-58
Output logic, manual mode	6-61
Output logic, fast response mode	6-61
logic diagram, functional	6-60
maximum current vs load type	6-59
mode selection	6-61
module reference/logic symbol definition	6-62
sample input circuit	6-63
sample output circuit	6-63
specifications	6-58, 6-59
truth table for fast response mode	6-61
wiring	6-63
Field wiring terminals	2-4
bottom terminals	2-4, 6-1
circuit annotation	2-4
top terminals	2-4, 6-1
plastic cover	2-4
removable paper inserts	2-4
Field wiring to I/O modules	6-2
Field wiring to basic units	6-1
Flat ribbon cable, programmer	2-4
Forcing I/O references	4-18

OFF	4-18, 5-35
ON	4-18, 5-35
Front and side panel features	2-3
26 pin connector	2-4
battery compartment access cover	2-5
I/O status display	2-4
field wiring terminals	2-4, 2-5
status indicator lights	2-3
BATT	2-3
CPU	2-3
PWR	2-3
RUN	2-3
PROM socket	2-6
Function of I/O circuitry	1-7
Fuse list	7-7
Fusing information	7-7
General specifications, Series One Junior	1-3
Glossary of terms	A-1
Hard-copy printout	2-12
High speed counter, built-in	1-3, 5-25
count pulses, circuit 15	1-3
count enable input	5-25
operation	5-26
programming	5-25
program example	5-27
pulse reset, circuit 16	1-3
reference	5-25
reset input	5-25
timing chart	5-27
How to begin programming	5-8
I/O Simulator module	6-64
faceplate	6-64
specifications	6-64
I/O circuitry, function of	1-7
I/O expansion module faceplate	2-9
I/O expansion rack references	2-8
I/O expansion requirements	2-8
I/O field wiring, instructions	3-8
I/O field wiring, wire size	3-7
I/O interface cable wiring list	6-3
I/O module placement in racks	2-11
I/O module replacement procedure	7-4
I/O reference, forcing	5-35
I/O references	5-1
I/O references per slot location	2-8
I/O status display	2-4
IC609CBL191	2-2
IC609CBL192	2-2
IC609CBL193	2-2
IC609EXP101	2-2, 6-86
IC609EXP110	2-2, 6-65
IC609EXP120	2-2, 6-67
IC609EXP121	2-2, 6-70
IC609SJR100	2-2, 2-5, 6-5
IC609SJR101	6-82
IC609SJR110	2-2, 6-13
IC609SJR102	2-2, 6-9

IC609SJR114	2-2, 6-13
IC609SJR120	2-2, 6-17
IC609SJR121	2-2, 6-21
IC609SJR124	2-2, 6-17
IC610ACC100	2-2
IC610ACC150	2-2
IC610ACC151	2-2
IC610CBL100	2-2
IC610CBL102	2-2, 2-7
IC610CBL152	4-24
IC610CCM100	2-2
IC610CCM109	2-2, 2-8
IC610CHS110	2-2, 2-8
IC610CHS111	6-89
IC610CHS114	2-2, 2-8
IC610CHS120	2-2, 2-8
IC610CHS124	2-2, 2-8
IC610PER151	2-2
IC610PER154	2-2
IC610PRG100	2-2, 3-8
IC610PRG190	2-2, 3-9
Insert one logic element	4-15
Installation instructions	3-3
Installation of programmer	3-8
Installation, programmer cable	3-9
Installation specifications	3-1
Series One Junior	3-1
Expansion Rack	3-2
Internal functions	1-3
counters	1-3
internal coils	1-3
non-retentive	1-3
retentive	1-3
sequencers	1-3
shift registers	1-3
timers	1-3
Ladder diagram format	5-6
Latches	5-15
Lithium battery	1-6
Lithium battery location	7-6
Logic display, description of	4-3
Logic keys, use of	4-3
Master control relay description	5-16
multiple function	5-17
programming of	5-17
sample logic	5-17, 5-18
Memory	1-2
CMOS RAM	1-2, 1-6
EPROM	1-2, 1-6
Monitor CPU logic	4-13
Monitor I/O status	4-16
Monitor counter status	4-17
Monitor timer status	4-16
Motor starter logic description	5-11

Motor starter relay logic	5-10, 5-11
Mounting an expansion rack	3-3
Mounting dimensions	3-2
basic unit	3-2
expansion racks	3-3
Mounting the basic unit	3-3
Non-volatile storage	2-13
Normally closed input description	5-12
Octal based numbers	5-1
Operation sequences, table of	4-12, 4-13
Operation with peripheral devices	4-19
Output disabler coil, 376	5-18, 5-19
effect of	5-19
sample logic	5-19
PROM socket	2-5
PROM orientation into socket	2-5
PROM writer unit	1-3, 2-13, 4-34
PROM writer unit features	
BLANK pushbutton/LED	4-35
CMPR pushbutton/LED	4-36
CPU LED	4-35
ERR pushbutton/LED	4-36
PROM to RAM sequence	4-36
PWR LED	4-35
WRITE pushbutton/LED	4-35
external power supply connector	4-37
power supply select switch	4-37
write sequence	4-36
PROM writer unit operation	4-36
PROM writer unit, illustration of	4-34
Panel depth	2-11
Parallel logic, illustration of	4-4
Peripheral device, operation of	4-19
Power connections	3-5
Expansion rack	3-5
Series One Junior	3-5
Power flow, concept of	5-6
Power supply limitations for expansion racks	3-10
Printer interface unit	1-3, 2-12, 4-23
Printer interface unit, hardware desc.	4-24
Printer interface unit, hardware features	4-25
80/132 column selection switch	4-26
CPU LED	4-25
Cross reference printout	4-28
Error message printing, ladder diagram	4-27
Error message printing, boolean listing	4-28
FORM pushbutton/LED	4-25
Outputs used table	4-28
PRNT pushbutton/LED	4-25
PROD pushbutton/LED	4-25
PWR LED	4-25
STOP pushbutton/LED	4-25
expanded print format	4-29
external power supply connector	4-26

power supply select switch	4-26
power-up sequence	4-26
printout annotation explanation	4-29
selection of printout format	4-27
selection of type of PC	4-27
start printer operation	4-27
user program transfer from PC	4-27
Printer interface unit, illustration of	4-24
Printer interface unit, operation of	4-26
Sample printout, boolean	4-31
Sample printout, ladder diagram	4-30
Sample printout, outputs used table	4-32, 4-33
Printer requirements	4-23
Printout, hard-copy	2-12
Program checking	4-8
Program development	5-7
Program error codes	4-8
Programmable controller	
advantages	1-1
block diagram, general	1-5
central processor unit	1-5
concepts	1-5
history of	1-1
programmer	1-5
series One Junior	1-1
terminology	1-8
Programmer	1-3
cable, installation	3-9
extender cable	3-8
Programmer features	4-1, 4-2
Address/data display	4-2
Editing keys	4-5
CLR	4-6
DEL	4-5
ENT	4-6
INS	4-5
NXT	4-6
PRV	4-6
SCH	4-6
SHF	4-6
Logic display	4-3
ADR LED	4-3
SHF LED	4-3
Logic keys	4-3
AND	4-3, 5-5
CNT	4-4, 5-5
MCS	4-5, 5-5
MCR	4-5, 5-5
NOT	4-4, 5-5
OR	4-3, 5-5
OUT	4-4, 5-5
RST	4-5, 5-5
STR	4-3, 5-5
SR	4-5, 5-5

SET	4-5, 5-5
TMR	4-4, 5-5
Mode switch	4-2
Status display	4-2
BATT LED	4-2
CPU LED	4-2
ON/OFF LED	4-2
PWR LED	4-2
RUN LED	4-2
Programmer installation	3-8
Programmer mount assembly	2-4, 2-7
Programmer mount assembly, installation of	3-9
Programmer operation, hand held	2-4
Programmer tape port	2-5
Programmer, illustration of	4-1
Programming AND•STR and OR•STR instructions	5-14
Programming a latched coil	5-15
Programming functions	5-7, 5-8
Programming language	1-3
Programming references	5-1
Pull tab, extender cable	3-8, 3-9
RUN relay	3-6
Rack mount brackets	2-11
Reference flexibility	5-3
References, unlimited use of	5-6
Relay Output module, 8 Circuit	6-51
maximum current vs load type	6-51
sample output circuit	6-52
specifications	6-51
wiring	6-52
Relay Output, w/Rem Term Board	6-104
Replacement of components	7-3
basic unit	7-3
expansion rack	7-5
expansion rack I/O modules	7-4
internal fuses	7-8
lithium battery	7-5
Retentive coils as latches	5-15
Routing of field wiring	2-11
Rung with series contacts	5-8
Search CPU logic	4-13
Sequencers	5-28
example of	5-29
illustration of operation	5-28
logic example	5-30
Series One Junior catalog numbers	2-2
accessories	2-2
basic units	2-2
expansion I/O modules	2-2
I/O expansion racks	2-2
I/O expansion cables	2-2
I/O expansion units	2-2
programmer	2-2
Series One Junior fuse list	7-7

Series One Junior programming	5-4
Series and parallel groups of logic	5-13
Series logic, illustration of	4-4
Shift registers	5-31
example of	5-32
operation	5-32
references	5-2, 5-32
sample logic	5-34
typical	5-31
Shifted functions	4-7
CHECK	4-8
MON	4-7
READ	4-7
WRITE	4-7
Side panel connector	2-5
Socket, PROM	2-6
Special purpose coils	5-1, 5-2
Specifications, general	1-3
Specifications, installation	3-1
Specifications, printer interface unit	4-23
Starting your program	5-8
Status display, description of	4-2
Status indicator lights	2-3, 2-9
DIAG	2-9
PWR	2-9
Support devices	1-3
Tape port, programmer	2-6
Tape recorder operation	4-19
loading a program	4-22
recording a program	4-19
verifying a program	4-20
Terminology, PC	1-8
Timer/Counter Setpoint Unit	4-37
references	4-39
remote mounting	4-39
specifications	4-38
Timer and counter extended range, example of	5-24
Timer and counter functional description	5-20
Timer and counter range, extending of	5-24
Timer references	5-2
Timer, logic example	5-20
Timers, logic requirements	5-20
Timers, programming of	5-20
Troubleshooting aids	7-1
Troubleshooting indicators, location of	7-1
Troubleshooting procedure, basic	7-1
Troubleshooting procedure, general	7-1
Typical I/O module, illustration of	6-2
Typical I/O module, terminal arrangement	6-2
UL listed products	6-81
5-slot rack	6-89
115 V ac Input module	6-90
115 V ac Input/Output Basic Unit	6-82
115 V ac Input/Output Expansion Unit	6-86

115 V ac Output module	6-94
Relay Output module	6-92
Units of load	3-10, 3-11
supplied by rack	3-11
used by I/O modules	3-11
Use of internal coils	5-1
Use of special purpose coils	5-2
373, set retention coils	5-1
374, first scan reset	5-1
375, 0.1 second clock	5-1
376, disable all outputs	5-1
377, battery status	5-1
Volatile memory	1-6
Volume control range setting	4-21
Watchdog timer	5-3