



This Datasheet for the

[IC670CHS004](#)

TC Cold Junction Compensation Base

<http://www.qualitrol.com/shop/p-14504-ic670chs004.aspx>

Provides the wiring diagrams and installation guidelines for this GE Field Control module.

For further information, please contact Qualitrol Technical Support at

1-800-784-9385

support@qualitrol.com

Thermocouple Terminal Block

IC670CHS004

GFK-1327
March 1996

Description

The Thermocouple Terminal Block (IC670CHS004), which has two built-in thermistors, can be used to provide local reference junction compensation for thermocouples used in conjunction with Field Control Thermocouple modules.

Thermocouples are connected to the screw terminals on the Thermocouple Terminal Block.

Thermocouple modules are installed on a separate I/O Terminal Block (IC670CHS003, -002, or -001) and connected to Wire-to-Board connectors on the Thermocouple Terminal Block. Terminal Block IC670CHS003 provides connector to connector installation.

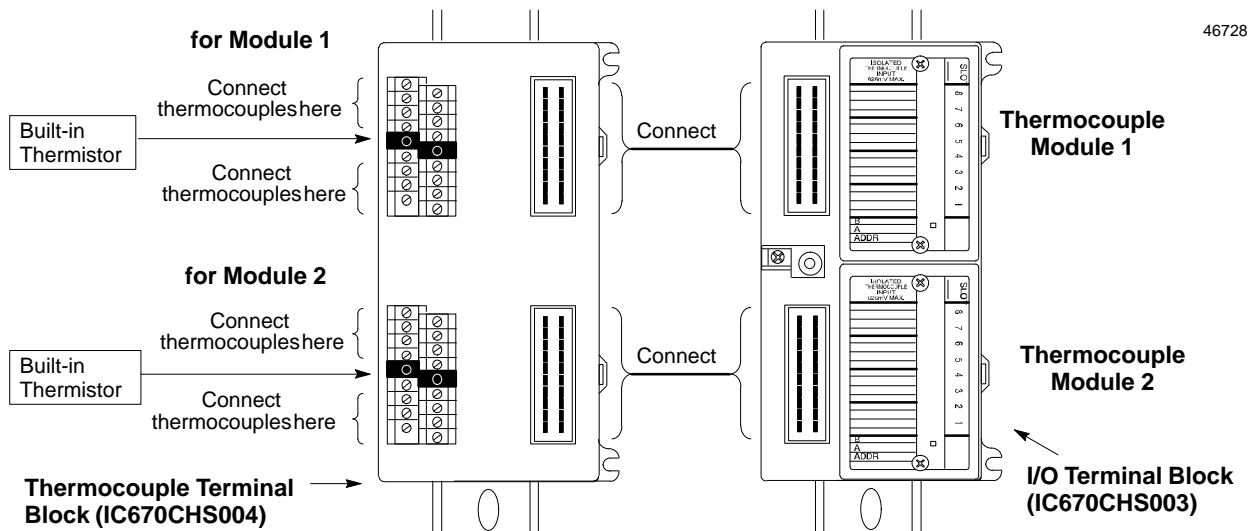

Installing/Removing a Terminal Block

The Thermocouple Terminal Block is mounted in the same manner as other Field Control terminal blocks.

Caution

The Thermocouple Terminal Block must be used with a grounded conductive DIN rail to assure that the assembly screws in the terminal block base cover are connected to chassis ground.

1. Tilt the terminal block and position it over the rail, catching the rail behind the tabs in the terminal block.
2. Pivot the terminal block downward until the spring-loaded latches click into place.

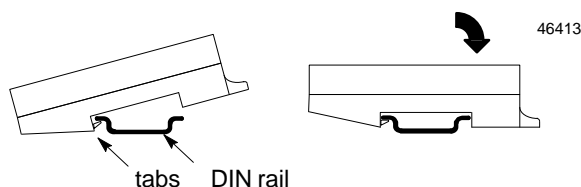

3. Tighten the DIN rail clamp screw. Maximum recommended torque is 8 in/lbs to 10 in/lbs.

Follow the steps below to remove a Terminal Block.

1. Loosen the DIN rail clamp screw.
2. Insert a small flat-blade screwdriver into the upper latch and pry it outward.
3. Pull up gently on the top of the terminal block to disengage the upper latch from the rail. Insert the screwdriver into the lower latch and pry it outward to free the terminal block.

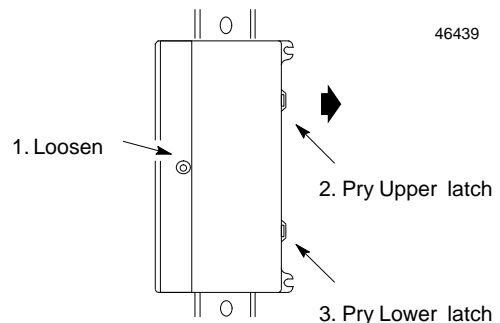

GFK-1327

Connecting Thermocouples to a Thermocouple Terminal Block

For each module, the connector pin assignments with the base mounted in the position shown above are:

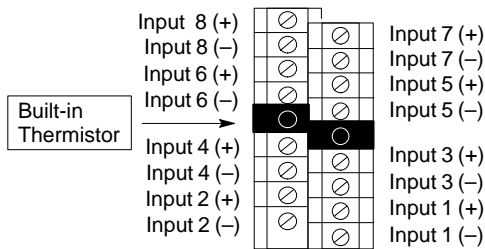

Connecting a Thermocouple Terminal Block to the I/O Terminal Block

Connect a Thermocouple Terminal Block to the I/O Terminal block using an appropriate cable. The diagram below shows the pin assignments for each Wire to Board connector on the Thermocouple Terminal Block.

Thermocouple Terminal Block (IC670CHS004) Wire to Board Connectors 46744

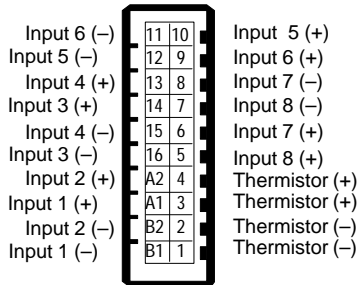

For ease of wiring, use of I/O Terminal Block with Wire-to-Board Connectors (IC670CHS003) is recommended. The illustration below shows the pin assignments for the Wire-to-Board connector on that terminal board.

I/O Terminal Block with Wire to Board Connectors (IC670CHS003)

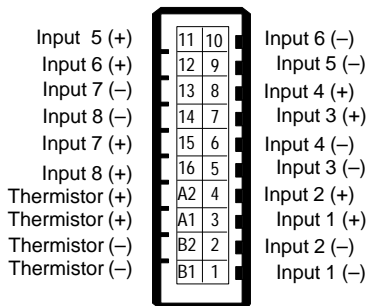

Using a Crimping Tool

Pins (catalog number IC670ACC003) must be installed on individual wires using a crimping tool. The AMP™ Pro-Crimper™ II, Hand Tool Assembly 90546-1 is recommended. The tool must be properly adjusted, as detailed in the instructions that come with the tool.

1. Strip the wire 3.96 to 4.75mm (0.156 to 0.187in), taking care not to nick or cut wire strands.
2. Hold the tool with the back (wire side) facing you. Squeeze tool handles together and allow them to open fully.
3. Holding the contact by the mating end, insert the contact—insulation barrel first—through the front of the tool into the appropriate crimp section. Position the contact with the mating end on the locator side of the tool, so that the open “U” of the wire and insulation barrels face the top of the tool. Place the contact up into the nest so that the movable locator drops into the slot in the contact. Butt the front end of the wire barrel against the movable locator.

NOTE: Be sure both sides of the insulation barrel are started evenly into the crimping section. DO NOT attempt to crimp an improperly-positioned contact.

4. Hold the contact in position and squeeze the tool handles together until ratchet engages enough to hold the contact in position. DO NOT deform insulation barrel or wire barrel.
5. Insert stripped wire into contact until it is butted against wire stop as shown.
6. Holding wire in place, squeeze tool handles together until ratchet releases.
7. Check the contact’s crimp height as described in the tool instruction sheet. Adjust the crimp height if necessary before continuing.

