



# *GE Fanuc Automation*

---

*Programmable Control Products*

*Genius<sup>™</sup>*  
*PowerTRAC<sup>™</sup> Block*

*User's Manual*

*GFK-0450D*

*May 1994*

## *Warnings, Cautions, and Notes as Used in this Publication*

### **Warning**

Warning notices are used in this publication to emphasize that hazardous voltages, currents, temperatures, or other conditions that could cause personal injury exist in this equipment or may be associated with its use.

In situations where inattention could cause either personal injury or damage to equipment, a Warning notice is used.

### **Caution**

Caution notices are used where equipment might be damaged if care is not taken.

### **Note**

Notes merely call attention to information that is especially significant to understanding and operating the equipment.

This document is based on information available at the time of its publication. While efforts have been made to be accurate, the information contained herein does not purport to cover all details or variations in hardware or software, nor to provide for every possible contingency in connection with installation, operation, or maintenance. Features may be described herein which are not present in all hardware and software systems. GE Fanuc Automation assumes no obligation of notice to holders of this document with respect to changes subsequently made.

GE Fanuc Automation makes no representation or warranty, expressed, implied, or statutory with respect to, and assumes no responsibility for the accuracy, completeness, sufficiency, or usefulness of the information contained herein. No warranties of merchantability or fitness for purpose shall apply.

The following are trademarks of GE Fanuc Automation North America, Inc.

Alarm Master	CIMSTAR	Helpmate	PROMACRO	Series Six	CIMPLICITY
Field Control	GENet	Logicmaster	Series One	Series 90	CIMPLICITY
90-ADS	Genius	Modelmaster	Series Three	VuMaster	CIMPLICITY
PowerTRAC	Genius PowerTRAC	ProLoop	Series Five	Workmaster	

This book provides information needed to install and use a Genius PowerTRAC™ block. It also describes the data transmitted between the block and a host PLC or computer. For programming details, you should refer to the documentation provided with the host.

## Content of This Manual

This book contains the following 6 chapters and 3 appendices.

**Chapter 1. Introduction:** Provides an overview of PowerTRAC block features and operation.

**Chapter 2. Installation:** Explains installation and field wiring for the block.

**Chapter 3. Configuration:** Describes the configurable features of the PowerTRAC block, and explains configuration step-by-step.

**Chapter 4. Calculated Data and Status Data:** Describes the data that is routinely transferred between a PowerTRAC block and its host PLC or computer. Chapter 4 also shows how the block's status data and calculated values can be read with a Hand-held Monitor.

**Chapter 5. Additional Calculated Data:** Describes additional data on power quality, line frequency, and temperature alarm status that is available from the PowerTRAC block.

**Chapter 6. Waveform Data and Overcurrent Data:** Explains how waveform and overcurrent data stored by the block can be accessed.

**Appendix A. Special Wiring Instructions:** Shows how to install the PowerTRAC block in applications where PTs or CTs cannot be connected to power as shown in the installation instructions in chapter 2.

**Appendix B. Using PTs and CTs with Higher Turns Ratios:** Explains how to configure the block for PTs having primary voltage greater than 327Kv and CTs having turns ratios greater than 32750:5 (6550:1). Appendix B also explains how to interpret data returned by the PowerTRAC block when this type of configuration is used.

**Appendix C. Using a PowerTRAC Block for Current Monitoring Only:** Describes the necessary wiring and configuration for a PowerTRAC block that will be used to monitor only current, where the application does not include any PT.

## **Related Publications**

*Genius I/O System User's Manual* (GEK-90486): The primary reference for information about Genius I/O products. It describes types of systems, system planning and installation, and system components.

*PowerTRAC Block Datasheet* (GFK-0366): A quick reference to block features, installation, and specifications.

At GE Fanuc Automation, we strive to produce quality technical documentation. After you have used this manual, please take a few moments to complete and return the Reader's Comment Card located on the next page.

*Jeanne L. Grimsby*  
Senior Technical Writer

<b>Chapter 1</b>	<b>Introduction</b> .....	<b>1-1</b>
	Overview .....	1-1
	Block Description .....	1-2
	Block Dimensions .....	1-2
	LEDs .....	1-2
	Hand-held Monitor Connector .....	1-2
	Block Power Required .....	1-2
	Specifications .....	1-3
	PTs and CTs .....	1-4
	Block Operation .....	1-5
	Data Available from a PowerTRAC Block .....	1-7
	Calculated Data and Status Data .....	1-7
	Additional Calculated Data .....	1-8
	Waveform Data and Overcurrent Event Data .....	1-8
	Systems .....	1-9
	Stand-alone Block .....	1-9
	Typical PLC System .....	1-10
	Hand-held Monitors .....	1-10
	Advanced Data Monitoring Systems .....	1-11
	Compatibility .....	1-12
	Typical Applications .....	1-13
	System Monitoring .....	1-13
	Multiple Load Monitoring .....	1-14
	Single-phase Monitoring .....	1-14
	Substation Monitoring .....	1-15
 <b>Chapter 2</b>	 <b>Installation</b> .....	 <b>2-1</b>
	Block Location .....	2-1
	Placing the Block in an Enclosure .....	2-1
	Installation Steps .....	2-1
	Install the Terminal Assembly .....	2-2
	Bus Wiring .....	2-3
	Installing the Block at the Beginning or End of the Bus .....	2-3
	Bus Connection for Critical Processes .....	2-4
	Stand-alone Installation .....	2-5
	Block Power Wiring .....	2-6
	Block Grounding .....	2-6
	Wiring from PTs and CTs .....	2-7
	Power Flow .....	2-7
	PT Connections: Line-to-Neutral PTs .....	2-8
	PT Connections: Line-to-Line PTs .....	2-9
	CT Connections .....	2-10
	Install the Electronics Assembly .....	2-12

<b>Chapter 3</b>	<b>Configuration</b> .....	<b>3-1</b>
	Overview .....	3-1
	Offline HHM Configuration Setup .....	3-2
	Select the HHM's Host CPU Type .....	3-3
	Connect the HHM .....	3-3
	Block ID and Reference Number .....	3-4
	Baud Rate .....	3-5
	Configuration Menu .....	3-5
	Block Features .....	3-6
	Default Configuration .....	3-6
	HHM Configuration Steps .....	3-6
	PT Connection .....	3-7
	Number of PTs .....	3-8
	Number of CTs .....	3-8
	Power Display Units .....	3-9
	PT Turns Ratio .....	3-10
	CT Turns Ratio .....	3-11
	NCT Turns Ratio .....	3-11
	Current Line Transient .....	3-12
	Auxiliary Current Transient .....	3-12
	Sign for VARs and Power Factor .....	3-13
	Send Extra Calculated Data .....	3-14
	BSM Present .....	3-15
	BSM Controller .....	3-15
	CPU Redundancy .....	3-16
	Configuration Protection .....	3-16
	Finishing Configuration .....	3-16
	Configuration Datagrams for the PowerTRAC Block .....	3-17

<b>Chapter 4</b>	<b>Calculated Data and Status Data</b> .....	<b>4-1</b>
	Automatic Data Transfer .....	4-1
	CPU Memory Usage .....	4-2
	Displaying Data With a Hand-held Monitor .....	4-4
	Status Inputs .....	4-5
	Displaying Status Inputs on a Hand-held Monitor .....	4-6
	Calculated Values .....	4-7
	Voltage, Line-to-Line .....	4-7
	Voltage, Line to Neutral .....	4-8
	Line Current .....	4-9
	Auxiliary Current .....	4-9
	Active Power .....	4-10
	Reactive Power .....	4-11
	Power Factor .....	4-12
	Accumulated Power .....	4-13
	Command Outputs .....	4-14
	HHM Command Outputs Displays .....	4-15
 <b>Chapter 5</b>	 <b>Additional Calculated Data</b> .....	 <b>5-1</b>
	Displaying Additional Calculated Data with a Hand-held Monitor .....	5-2
	Fundamental VARs .....	5-3
	Fundamental Power Factor, Total .....	5-4
	Harmonic VARs as % of Volt-Amps .....	5-5
	Total Harmonic VARs as a Percent of V-A .....	5-7
	Line Frequency .....	5-8
	Temperature Alarm Status .....	5-8
	Extended Watt-hour Accumulator .....	5-9
	Sending Datagrams to Read Calculated and Status Data .....	5-10
	Datagram Timing .....	5-10
	Read Device Datagram for Calculated and Status Data .....	5-10
	Reply Datagram Sent by the PowerTRAC block .....	5-12

<b>Chapter 6</b>	<b>Waveform Data and Overcurrent Data</b> .....	<b>6-1</b>
	Input Data Tables .....	6-1
	Table Format .....	6-2
	Sampled Waveform Data .....	6-3
	Harmonic Analysis of Waveform Values .....	6-3
	Overcurrent Data .....	6-4
	Reading Table Data from a PowerTRAC block .....	6-6
	Requesting Data Transfer .....	6-6
	Notifying the Controller that Data is Ready .....	6-7
	Sending Data to Monitoring Devices .....	6-8
	Completing the Process .....	6-8
	Example .....	6-9
	Sending Datagrams to Read Table Data .....	6-10
	Datagram Timing .....	6-10
	Read Device Datagram for Table Data .....	6-10
	Reply Datagram Sent to the Requesting Device .....	6-12
	Converting the Data to Voltage or Current .....	6-12
<b>Appendix A</b>	<b>Special Wiring Instructions</b> .....	<b>A-1</b>
	Required PT and CT Connections .....	A-1
	Redefining Power Phases .....	A-2
	Basic Wiring Instructions .....	A-3
	2 line-to-neutral PTs with 1 or 3 CTs .....	A-4
	2 line-to-neutral PTs with 2 CTs .....	A-5
	1 line-to-neutral PT with 1 or 3 CTs .....	A-6
	3 Line-to-line PTs with 1 or 3 CTs .....	A-7
	2 line-to-line PTs with 1 or 3 CTs .....	A-8
	2 line-to-line PTs with 2 CTs .....	A-9
	1 line-to-line PT with 2 CTs .....	A-10
<b>Appendix B</b>	<b>Using PTs and CTs With Higher Turns Ratios</b> .....	<b>B-1</b>
	Configuring Fractional Turns Ratios .....	B-1
	Fractional PT Turns Ratio .....	B-1
	Fractional CT Turns Ratio .....	B-2
	Fractional Calculated Values .....	B-2
	Fractional Calculated Power Values .....	B-3
	Recording Changed Turns Ratios .....	B-3
<b>Appendix C</b>	<b>Using a PowerTRAC Block for Current Monitoring Only</b> .....	<b>C-1</b>
	Installation Instructions .....	C-1
	Configuration .....	C-2
	Monitoring Data .....	C-2
	Related Publications .....	iv



# Chapter 1

## Introduction

### Overview

The Genius™ PowerTRAC™ block is used in many types of power monitoring and industrial applications. The PowerTRAC block monitors current and voltage inputs and stores digitized waveform values for each input. From these values, the block calculates RMS voltage, current, active power, reactive power, KWH, and power factor. The block automatically sends this calculated data to a host PLC or computer approximately twice per second. The same data can be displayed on a Genius Hand-held Monitor, either locally or from any connection point the bus.

A PowerTRAC block can be used with a wye- or delta-configured three-phase power system or with a single-phase power system. It accepts voltage inputs from one to three potential transformers, and current inputs from up to three line current transformers, plus a neutral current transformer.

The PowerTRAC block:

- Accurately measures RMS voltage, current, power, VARs, power factor, watt-hours, and line frequency, even with distorted waveforms.
- Provides simple user connections.
- Has low current transformer burden (less than 0.5VA).
- Indicates magnitude of system harmonic content.
- Detects and captures overcurrent transients. Overcurrent threshold is user-configurable.
- Can be mounted in distribution or process equipment.
- Can be installed on a Genius bus up to 7500 feet from the host PLC or computer.
- Can be used in stand-alone applications without a host. The block will automatically provide operator displays on a Genius Hand-held Monitor.
- Has an integral power supply, and accepts either 115/230VAC or 125 VDC inputs.
- Is software configurable from the host or from a Hand-held Monitor.

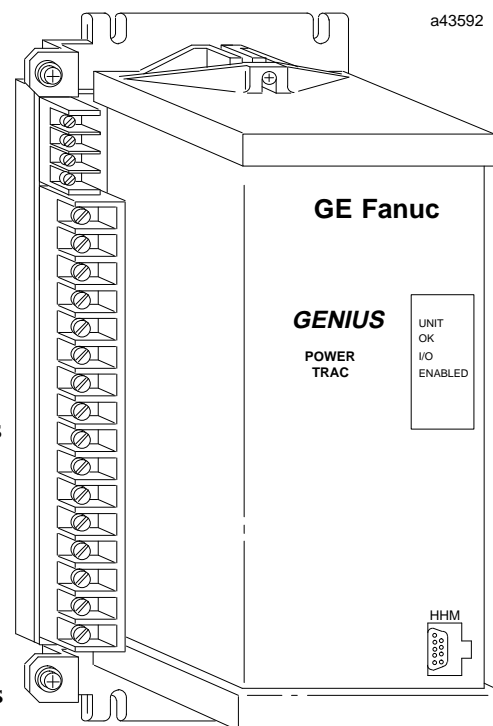

## Block Description

The block has two parts: a Terminal Assembly, to which all fixed wiring is attached, and an Electronics Assembly. The Electronics Assembly may be inserted or removed without disturbing field wiring or block configuration.

Inputs from current transformers and potential transformers are wired to the Terminal Assembly. The Terminal Assembly is also used to connect the block to the communications bus. The Terminal Assembly is normally permanently mounted.

## Block Dimensions

Dimensions of the PowerTRAC block are shown below.

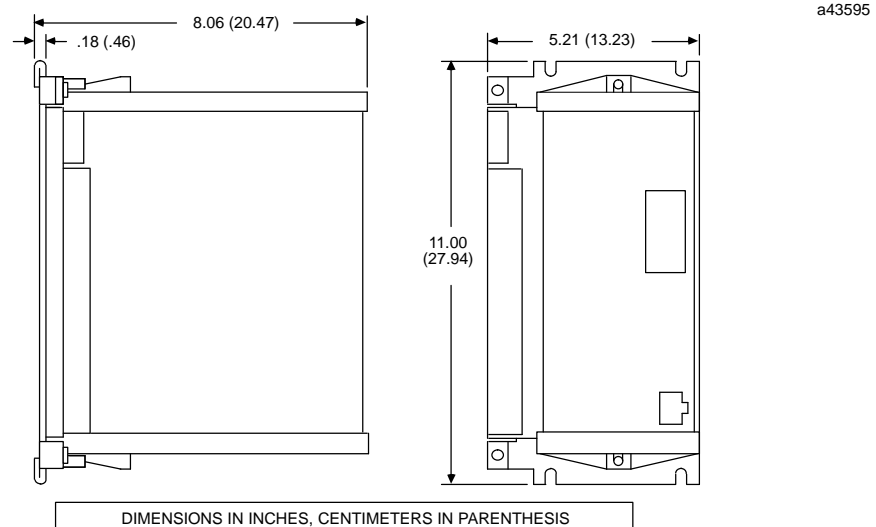

The PowerTRAC block is larger than other Genius I/O Blocks.

## LEDs

The OK and I/O Enabled LEDs on the front of the Electronics Assembly indicate the status of the block and of the communications bus.

## Hand-held Monitor Connector

The front of the Electronics Assembly also provides a convenient connector for a Genius Hand-held Monitor. The Hand-held Monitor is used to complete the block's software configuration, and can also be used for monitoring functions during system operation.

## Block Power Required

The PowerTRAC block's universal- input type power supply allows it to be powered from either 115/230 VAC (90– 265 VAC) at 47 to 63 Hz, or 125 VDC (100– 150 VDC) at 35 VA, maximum.

# Specifications

<p><b>Voltage Inputs:</b></p> <p>Maximum Range</p> <p>Overvoltage range</p> <p>Burden per input</p> <p>Accuracy of measured voltages</p> <p>Configurable PT turn ratios</p> <p><b>Power Measurement Accuracy:</b></p> <p><b>Current Inputs:</b></p> <p>Maximum Nominal range</p> <p>Overcurrent range</p> <p>Overcurrent withstand</p> <p>Burden per input</p> <p>Accuracy of measured current</p> <p>5 amps secondary</p> <p>Configurable CT turn ratio</p> <p><b>Power Requirements, 35 VA maximum:</b></p> <p><b>Terminal Wiring:</b></p> <p><b>LEDs:</b></p> <p><b>Functionality:</b></p> <p>Voltage</p> <p>Current</p> <p>Active Power</p> <p>Reactive Power</p> <p>Power Factor</p> <p>Update Rate</p> <p><b>Environmental:</b></p> <p>Operating Temperature</p> <p>Storage Temperature</p> <p>Humidity</p> <p>Vibration</p> <p><b>Dimensions:</b></p>	<p>three phases</p> <p>0 to 120 VAC RMS at 47 to 63 Hz</p> <p>up to 300V peak</p> <p>less than 0.1 VA</p> <p>0.25% reading + 0.25% full scale</p> <p>up to 327670:120 (2730:1). Higher primary voltages may be scaled external to PowerTRAC block.</p> <p>0.75% reading + 0.75% full scale</p> <p>three phases</p> <p>0 to 5 amps RMS at 47 to 63 Hz</p> <p>5 to 50 amps RMS at 47 to 63 Hz</p> <p>50 amp for 5 sec, at 10 minute intervals</p> <p>less than 0.5 VA</p> <p>0.50% reading + 0.50% full scale</p> <p>up to 32750:5 (6550:1)</p> <p>115 VAC/230VAC (90–265VAC), 47–63Hz or 125VDC (100–150VDC), 35VA max.</p> <p>for Genius I/O bus, one AWG #12 or two AWG #14 for power, CTs, and PTs: up to AWG #10</p> <p>Unit OK, Communications OK</p> <p>Phase to phase (wye and delta) Phase to neutral (wye system)</p> <p>Per phase and neutral</p> <p>Per phase</p> <p>Per phase</p> <p>Effective system PF</p> <p>2 / second for calculated values and status data</p> <p>0C to +60C (+32F to +140F)</p> <p>–40C to +100C (–40F to +212F)</p> <p>5% to 95% non-condensing</p> <p>1.0 G 10–200Hz</p> <p>5.21" w. X 11.00" h. X 8.06" d. 13.23cm w. X 27.94cm h. X 20.47cm d.</p>
--	--

- Electronics removable from terminal strip while maintaining electrical continuity on CT secondaries.
- Designed in accordance with UL and CSA, ANSI 37.90, NEMA 2–230, IEEE 587

## Ordering Information

<b>PowerTRAC block</b>	IC660BPM100
------------------------	-------------

## PTs and CTs

The PowerTRAC block can be used with one to three potential transformers and up to three current transformers. There must be at least one voltage input with a secondary voltage of 30 VAC to synchronize the PowerTRAC block to the line frequency. However, it is possible to use the PowerTRAC block without any current transformer.

### Monitoring Current Only

The block can be used to monitor current only if at least one voltage input is connected. Special instructions for this are given in appendix C.

### PTs

The PowerTRAC block can be used with any potential transformer having a secondary rating of 120 VAC at 47 to 63 Hz. The block automatically calculates primary voltages up to 327KV (PT turns ratio 2730:1). PTs with higher primary voltages can also be used with the block (see appendix B for details). Voltage inputs are nominally 120 VAC RMS with measurement capability up to 300 volts peak. Accuracy specifications are based on 120 volts full scale. Potential transformers may be connected line-to-neutral or line-to-line.

### CTs

Current transformers must have a secondary rating of 5 amps maximum at the PowerTRAC input. The block automatically calculates primary currents up to 32750 amps for line connections or 3275 amps for auxiliary (neutral) connections, although CTs with higher primary ratings can be used (see appendix B). Accuracy specifications are based on 5 amps full scale. For maximum accuracy, you should use the smallest current transformer that will handle the requirements.

The block processes current inputs to maximize accuracy and resolution over the nominal 5 amp range with overload capability up to 10x the rated current (50 amps). Current transformer burden is 0.5VA maximum. For safety, CT burdens are permanently connected across the Terminal Assembly's CT input terminals. No spring type contacts are used, and no shorting bars are required for Electronics Assembly servicing or replacement; burden is maintained with the Electronics Assembly removed.

## Block Operation

The PowerTRAC block uses both analog and digital techniques to provide accurate, stable measurements which are fully updated twice per second.

To accomplish this, the block samples all current and voltage inputs for eight consecutive cycles at a rate 16 times the line frequency. As a result, each input waveform is digitized with 128 samples. These composite waveforms are stored in a Working Data Table for computation of the new measurements. The stored waveforms might also be used for harmonic analysis; they can be read by a PLC or computer using datagrams.

Both voltage and current inputs are processed to maximize accuracy over the specified measurement range, while still providing the ability to track overload conditions at a reduced accuracy. Sampling is referenced to line frequency using phase-lock loop for repeatability.

From the 128 stored sampled values for each input, the block calculates voltage, current, active and reactive power, power factor, and power consumed or supplied.

The block automatically updates the calculated data values sent to the programmable controller and/or host computer on the Genius bus approximately twice per second. The same data can be displayed on a Hand-held Monitor, which may be connected at any location in the Genius bus or directly attached to the PowerTRAC block itself.

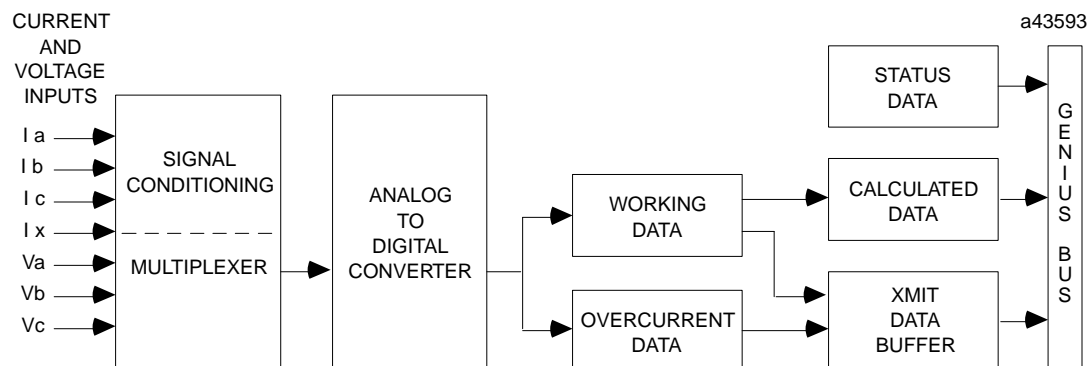

If a current exceeds a configurable level, the block captures that input waveform, as well as waveforms present on all other inputs. The digitized inputs are stored in an internal table called the Overcurrent Data Table. The block will supply waveform data to the PLC or computer, for harmonic or overcurrent analysis, upon request.

### Simultaneous Input Sampling

All current and voltage inputs are sampled *simultaneously*.

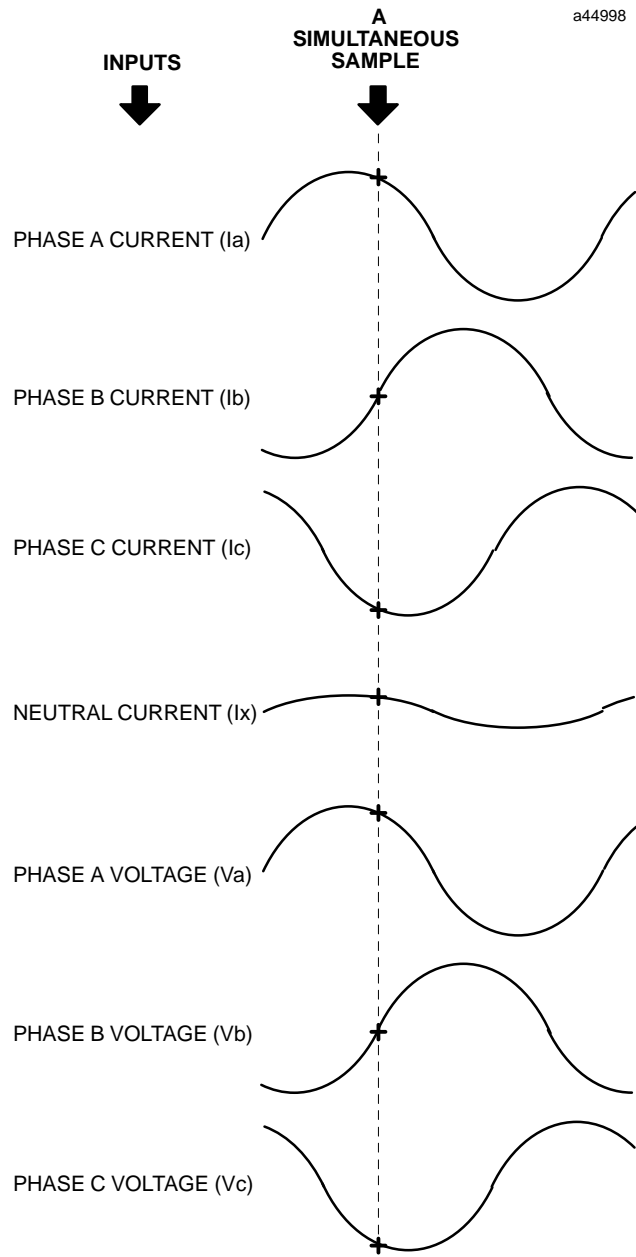

a44998

This sampling technique maintains proper phase relationships in the calculated data.

# Data Available from a PowerTRAC Block

A PowerTRAC block can provide three basic types of data:

- **Calculated Data and Status Data**  
18 words (36 bytes) of calculated values plus 1 word (2 bytes) of handshaking and status data, which are automatically broadcast by the block, and available to all other devices on the bus.
- **Additional Calculated Data**  
12 words (24 bytes) of calculated values, which may be automatically sent, or requested from a Hand-held Monitor or host.
- **Waveform and Overcurrent Event Data**  
Two tables of waveform values, which are available by request from the host, using the handshaking protocol.

## Calculated Data and Status Data

Approximately twice per second, the block takes 128 samples from 8 cycles of each voltage input from potential transformers and each current input from current transformers. It then calculates the following values:

- Voltage phase A to B
- Voltage phase B to C
- Voltage phase C to A
- Voltage phase A to N (for line-to-neutral potential transformers only)
- Voltage phase B to N (for line-to-neutral potential transformers only)
- Voltage phase C to N (for line-to-neutral potential transformers only)
- Current phase A
- Current phase B
- Current phase C
- Auxiliary CT current
- Active power phase A
- Active power phase B
- Active power phase C
- Reactive power phase A
- Reactive power phase B
- Reactive power phase C
- Total power factor
- Total watt-hours/KWH/MWH

Each bus scan, the block also automatically sends 16 bits of overcurrent event and handshaking status information. In return, the PLC or computer sends 16 output control bits to the block. This transfer of status and control bits establishes a handshaking protocol which can be used by the host to set up transfer of waveform data.

## Additional Calculated Data

In addition to the calculated data it automatically provides to the host, the PowerTRAC block calculates the following data. Depending on how the block is configured, this data may be automatically sent each bus scan, following the regular calculated data. Alternatively, it may be sent only on request by a Hand-held Monitor or host controller or computer.

- Fundamental VARS phase A
- Fundamental VARS phase B
- Fundamental VARs phase C
- Fundamental Power Factor
- Harmonic VARS as % of Volt-Amps phase A
- Harmonic VARs as % of Volt-Amps phase B
- Harmonic VARs as % of Volt-Amps phase C
- Total Harmonic VARs as % of Volt-Amps
- Line Frequency
- Temperature Alarm
- Extended Watt-hours (high)
- Extended Watt-hours (low)

## Waveform Data and Overcurrent Event Data

The block maintains two 1792-byte tables in its own memory. Each table holds sampled values representing 8 continuous cycles of each of the 3 voltage and 4 current inputs. In the waveform table, the data for each input is interleaved to form single-cycle waveforms consisting of 128 data samples each. The overcurrent event table holds transient waveform data for each input, consisting of 8 cycles of 16 samples each.

The controller or an optional monitoring device can request data from either table for harmonics analysis or overcurrent event analysis. Each transfer of this data must be set up by a prior exchange of handshaking bits, as explained in chapter 6.



# Systems

A PowerTRAC block can be used in many types of system, from very simple to highly complex:

- The simplest type of "system" consists of a stand-alone PowerTRAC block, a Hand-held Monitor, and no host PLC or computer.
- A PLC-host system may have many PowerTRAC blocks and other Genius I/O blocks on one or more communications busses.
- An advanced data monitoring system may have one or more computers reading and analyzing data from multiple PowerTRAC blocks and other blocks, with a host PLC or computer providing overall control.

## Stand-alone Block

A PowerTRAC block can easily be used as a stand-alone power-monitoring device. No host connection is required. A Genius Hand-held Monitor is used to configure the block, and to provide operator displays.

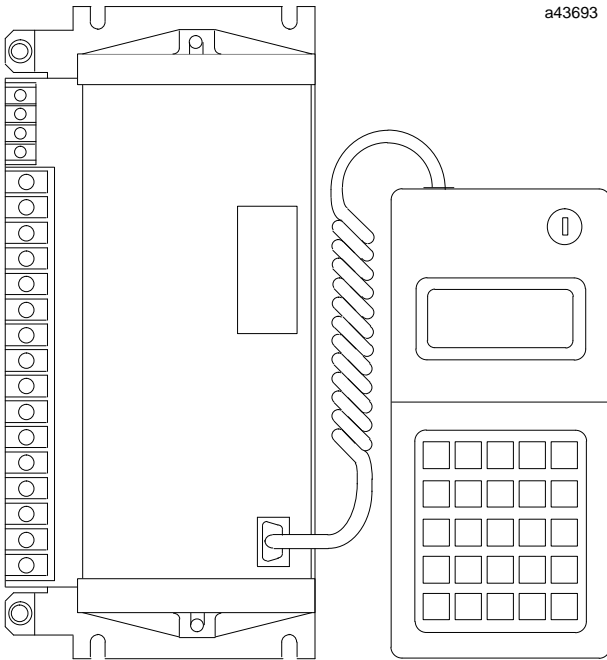

The Hand-held Monitor can be temporarily attached to the convenient connector on the front of the block, as shown above, or permanently installed beside the PowerTRAC block for use as an operator workstation.

The Hand-held Monitor will display all the status and calculated data provided by the block. Complete descriptions of the HHM screens are given in this book. The only data that is not available to a HHM in a stand-alone application is waveform and overcurrent event data.

## Typical PLC System

The PowerTRAC block can provide information to an application program running in a PLC or host computer. A PLC is preferred its for extensive control and data transfer capabilities.

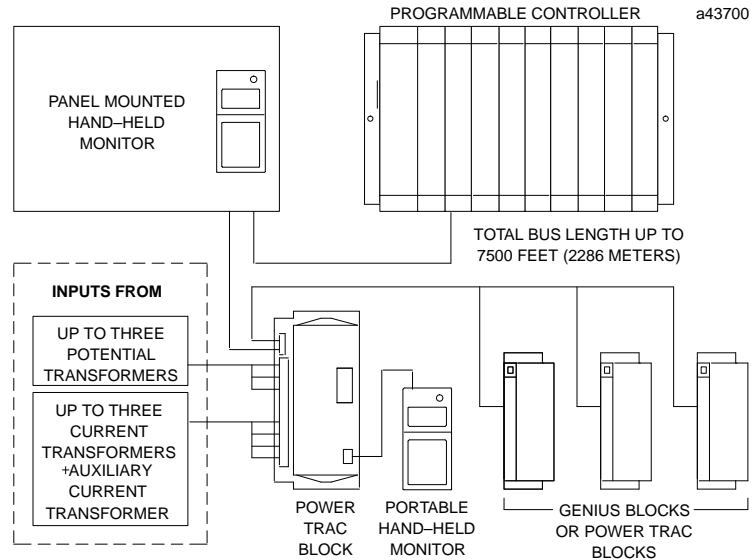

## The Communications Bus

The Genius I/O bus can be up to 7500 feet (2286 meters) in length. The same bus may serve other Genius I/O blocks performing a variety of monitoring and control functions. The maximum baud rate is 153.6 Kbaud for bus lengths up to 3500 feet. For longer busses, a slower baud rate must be selected. 38.4Kbaud must be used for 7500-foot busses (with a maximum of 16 devices on the bus).

## Additional Devices on the Bus

In addition to the PowerTRAC block, as many as 30 other devices can be connected to a bus. Any number of these may be PowerTRAC blocks. The number of PowerTRAC blocks in the system can depend upon the availability of memory in the host.

## Hand-held Monitors

One or more Hand-held Monitors can be used to display the block's calculated data, as well as status information which is automatically provided by the block. A portable Hand-held Monitor can be attached to any HHM connector on the bus, or directly to the PowerTRAC block. A Hand-held Monitor can also be permanently mounted on a panel for an operator workstation. If the system includes multiple Hand-held Monitors, they can display different data from the PowerTRAC block simultaneously. For example, one might display the calculated voltage while another displayed status information. (The Hand-held Monitors must have different Device Numbers to be used on a bus at the same time).

# Advanced Data Monitoring Systems

PowerTRAC blocks can be used with both PLCs and GE Fanuc Cimplicity software products for host computers, in a variety of industrial power measurement applications such as system monitoring, multiple load monitoring, and single-phase monitoring.

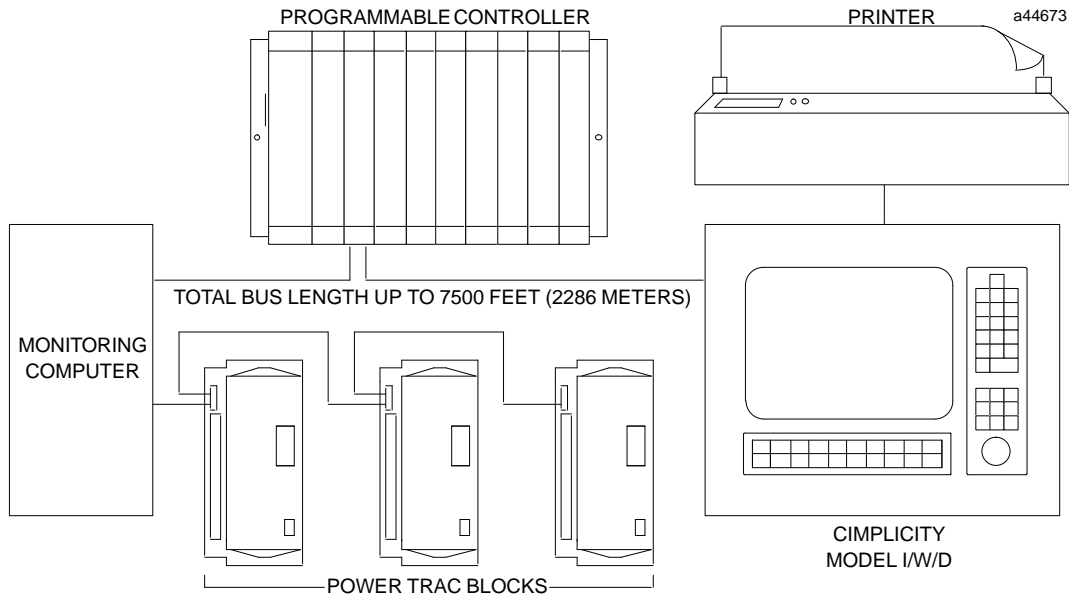

The information provided by the PowerTRAC blocks can be displayed in easily interpreted formats using Cimplicity software products. The Cimplicity products provide graphics status monitoring, trending, data logging, reporting, and alarming functions that work well with PowerTRAC blocks in power management systems.

## Compatibility

The Genius PowerTRAC block is compatible with:

### Hand-held Monitor

Hand-held Monitor (IC660HHM501) version 3.5\* or later provides basic compatibility with a PowerTRAC block. HHM version 4.0 or later is needed to display:

- Fundamental VARs
- Fundamental Power Factor
- Harmonic VARs as % of V-A
- Line Frequency
- Temperature Alarm Status

### Series 90™ -70 PLC

- CPUs: IC697CPU731G (rev 2.02) or later, IC697CPU771E (rev 2.02) or later.
- Logicmaster™ 90-70 Programming Software: release 2.03 (IC641SWP701/702) or later.
- Genius Bus Controller: version IC697BEM731C or later.

### Series Six™ PLC

- CPU: rev. 105 or later (Logicmaster 6 will display as 3.01 or later).
- Logicmaster 6 Programming Software: release 4.02 or later.
- Bus Controllers: IC660CBB902 or 903, version 1.7 or later.

### Series Five™ PLC

- CPU: rev. 4.0 or later.
- Logicmaster 5 Programming Software: release 2.01 or later.
- Bus Controller: any version

### Host Computers

- PCIM: any version
- QBIM: any version
- Cimplicity™ System 3000 Models I/W
- Cimplicity System 3000 Model D: rev. 3.0 or higher

\* (For Series Six PLCs only:) use of I/O Table references for the PowerTRAC block is not fully supported by version 3.8 and earlier of the Hand-held Monitor firmware. These HHMs assume that a PowerTRAC Block occupies 304 I/O references. When configuring blocks online, if you assign reference addresses within that range of 304 references to another bus device, the HHM assumes that a reference address conflict exists. Also, when monitoring the block, the HHM incorrectly displays a different reference address in the range of 304 inputs for each status and calculated data value. All values should show the same beginning I/O address. Use of HHM firmware version 4.0 or later avoids this problem.

## Typical Applications

The PowerTRAC block can be used in many types of power monitoring and industrial applications, such as system monitoring, multiple load monitoring, single-phase monitoring, and substation monitoring.

### System Monitoring

The PowerTRAC block can be used to monitor the magnitude and direction of power flow. It will provide data for load shedding and/or power factor correction.

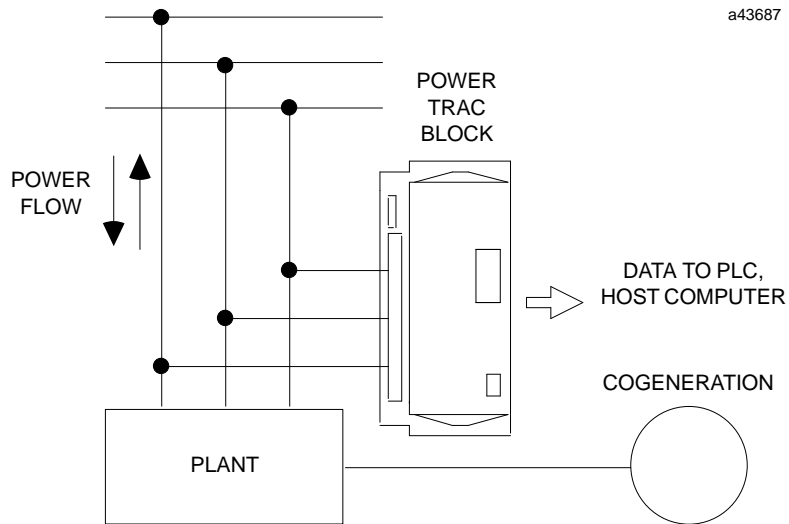

The PowerTRAC block provides a programmable controller or host computer with signed Watts and VARs signals for each phase, as well as system Power Factor. The same data can also be displayed on a Hand-held Monitor, as shown later in this book.

## Multiple Load Monitoring

The PowerTRAC block can be used in applications where three independent loads from a single 3-phase feeder must be monitored.

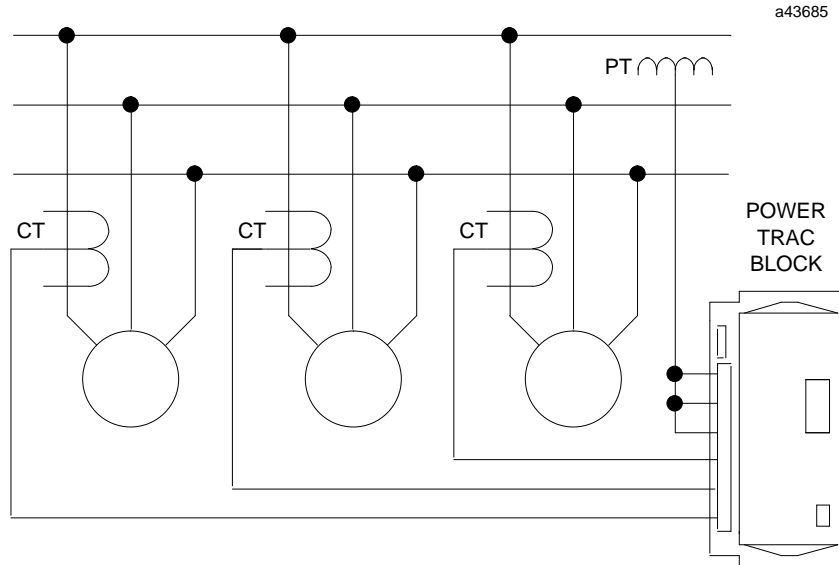

For accurate monitoring in this type of application, the voltage and load on each of the three phases must be balanced.

## Single-phase Monitoring

One PowerTRAC block can be used to monitor up to three independent single-phase circuits. The circuits can be the same phase or different phases.

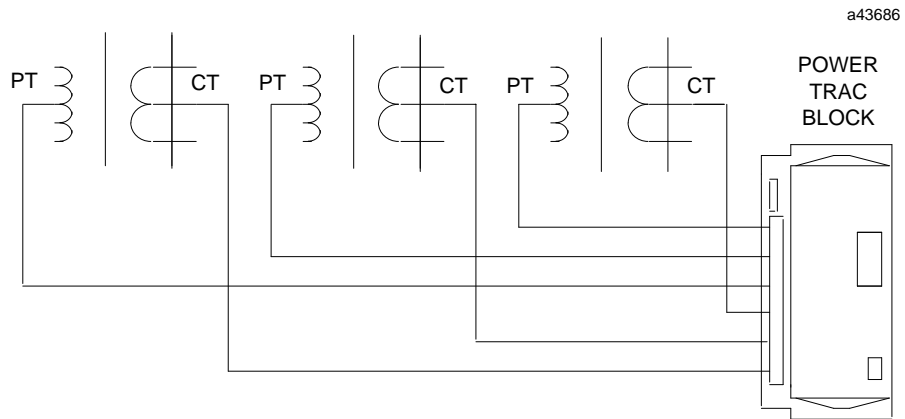

For 120 volt lines, no potential transformers are required. If the current is less than or equal to 5 Amps nominal, no current transformers are required.

## Substation Monitoring

The PowerTRAC block can be installed in switch gear to monitor power flow on main and feeder breakers in a factory.

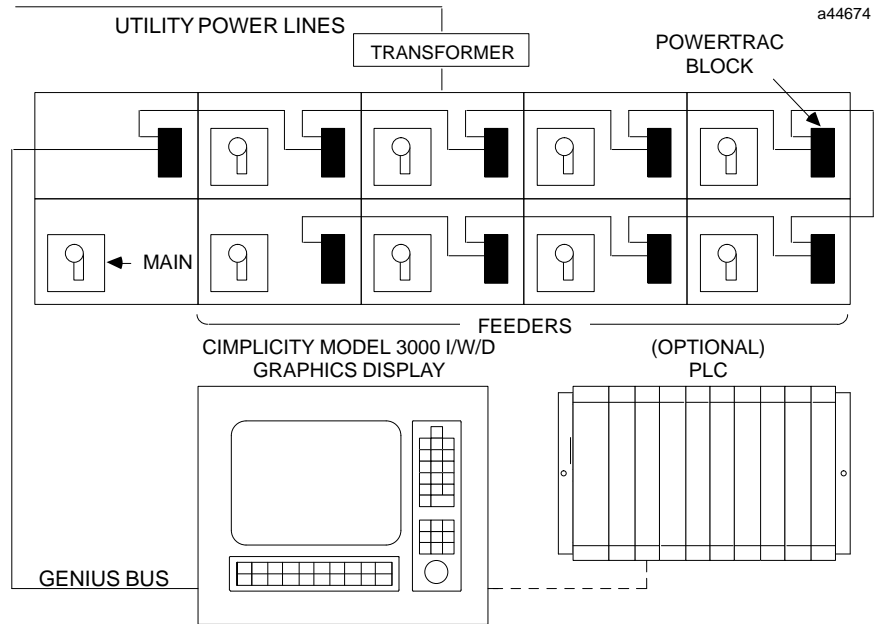

Power usage information can be collected over the Genius bus and displayed by a host computer, such as the example Cimplicity System 3000 Model I/W or D system represented below. The information gathered by the system can be used to develop power management strategies such as load scheduling, load shedding, or power factor correction. When control is needed, a PLC can be included in the system.

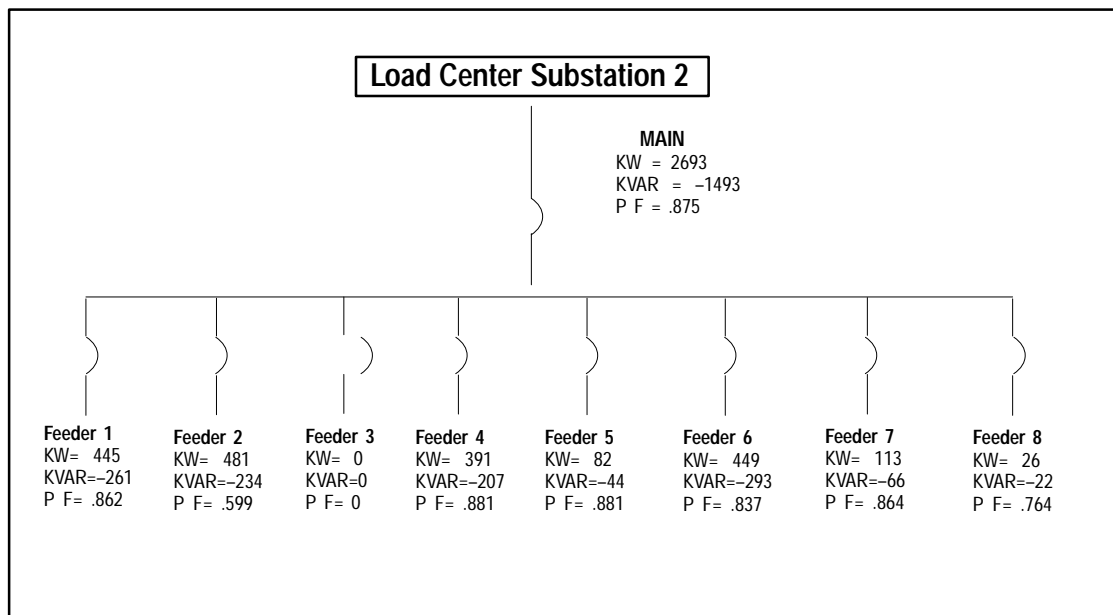

# Chapter 2

## Installation

---

---

This chapter describes installation and field wiring for the PowerTRAC Block.

### Block Location

The block can be individually installed on a machine, in a junction box, or on a rack or panel. If the block is located in an enclosed space, be sure to allow adequate clearance for routing wiring and for airflow around the block. Also be sure to leave room at the front of the block for connecting a Hand-held Monitor.

### Placing the Block in an Enclosure

If the intended location is unprotected, the block should be placed in an appropriate enclosure. The *Genius I/O System User's Manual* gives guidelines for enclosure selection. If the enclosure must be located in direct sunlight, consider placing a shade over it and/or painting it white. In locations where temperature may be lower than 32°F, the enclosure should be warmed using an internal heater with a thermostat.

The block should be installed in a reliably grounded location. Normally, a ground (green) wire is routed from the building power system to each control cabinet.

### Installation Steps

For easiest block installation, follow this sequence:

1. Remove the block's Electronics Assembly from the Terminal Assembly, then install the Terminal Assembly.
2. Complete the wiring to the Terminal Assembly.
3. Install the Electronics Assembly on the Terminal Assembly.
4. Apply power to the block.



# Install the Terminal Assembly

1. Drill mounting holes as indicated below at the intended location.

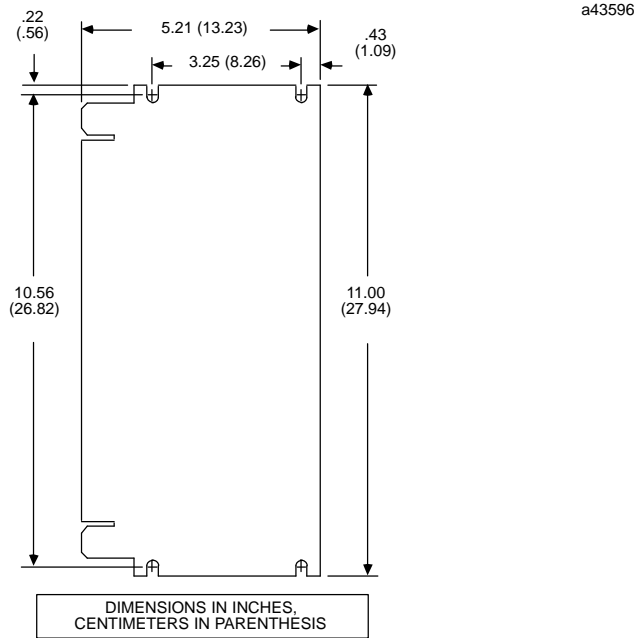

2. Loosen the retaining screws.
3. Grasp the block firmly, and pull the Electronics Assembly out straight, away from the Terminal Assembly. Place the Electronics Assembly in a protected location.

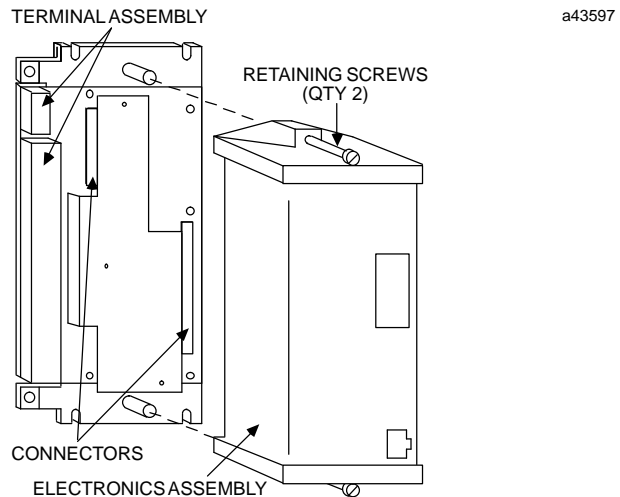

4. Line up the notches in the top and bottom of the Terminal Assembly with the drilled holes. Fasten the Terminal Assembly securely in place using up to #12 screws with star washers.

# Bus Wiring

If the block will be part of a host PLC or computer system, complete the communications bus wiring using one of the bus cable types recommended in the *Genius I/O System User's Manual*. Connect the Serial 1 terminals of adjacent devices and the Serial 2 terminals of adjacent devices. Connect Shield In to the Shield Out terminal of the previous device. Connect Shield Out to the Shield In terminal of the next device.

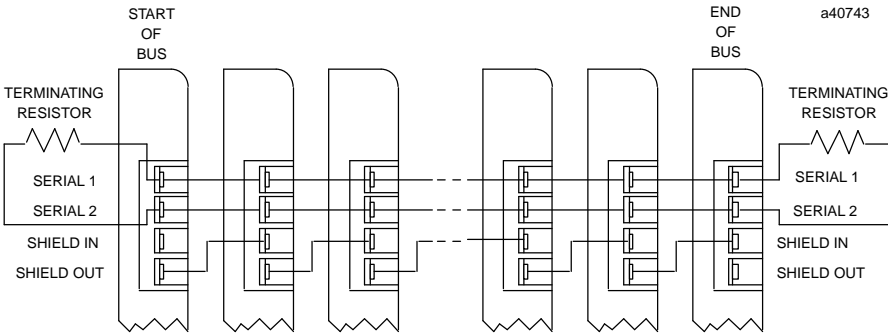

These terminals can accommodate spade or ring lugs up to 0.27 inch (6.85mm) in width with a minimum opening for a #6 screw, and up to 0.20 inch (5.1mm) depth from the screw center to the back barrier.

When making bus connections, the maximum exposed length of bare wires should be two inches. For added protection, each shield drain wire should be insulated with spaghetti tubing to prevent the Shield In and Shield Out wires from touching each other.

## Installing the Block at the Beginning or End of the Bus

If the block is at the beginning of the bus, its Shield In terminal is not connected. If the block is at the end of the bus, its Shield Out terminal is not connected.

If the block is at either end of the bus, connect a terminating resistor of the appropriate impedance across the Serial 1 and Serial 2 terminals. Impedance will be 75, 100, 120, or 150 ohms. The impedance selected must be correct for the cable type used for the bus. For information about cable types and terminating impedance, refer to the *Bus Controller User's Manual*, or to the *Genius I/O System User's Manual*.

## Bus Connection for Critical Processes

The recommended method of connecting the block to the bus is to wire the bus directly to the Terminal Assembly as described above. These bus connections are normally considered permanent. They should never be removed while the completed system is in operation; the resulting unreliable data on the bus could cause hazardous control conditions. If the possible removal or replacement of the block's Terminal Assembly would result in breaking the continuity of the bus, the bus should be turned off first. If the bus controls critical processes that cannot be shut down, the block can be wired to the bus via an intermediate connector, as shown below.

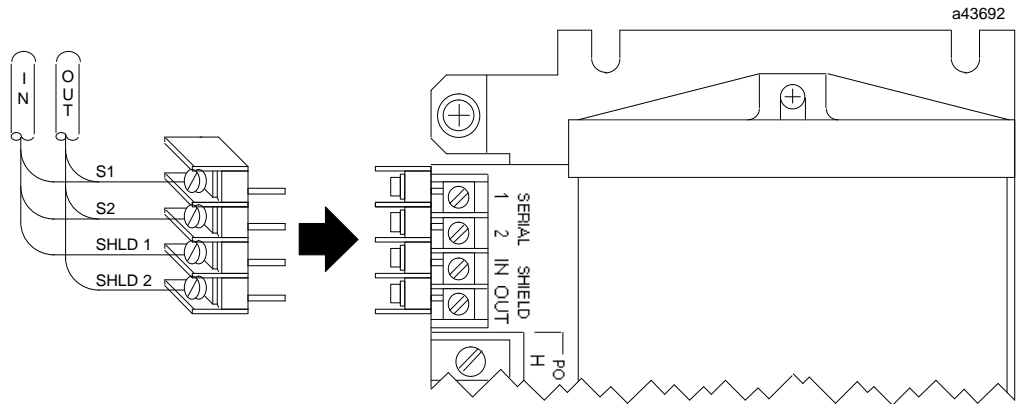

This will allow the block's Terminal Assembly to be removed while maintaining data integrity on the bus. The connector shown is #A107204NL from Control Design, 48 Crompton Street, Charlotte, NC, 28134.

Alternatively, the wire ends can be soldered together before inserting them into the block terminals. When removing the Terminal Assembly, the ends of the bus wires must be covered with tape or other insulating material to prevent shorting the signal wires to one another or to ground.

If the block is connected to the bus in this way, field wiring to the block should also provide a means of disconnecting power to the block.

# Stand-alone Installation

If the PowerTRAC block will be used as a stand-alone device, with no connection on a communications bus, install a 75-ohm terminating resistor across the Serial 1 and Serial 2 terminals.

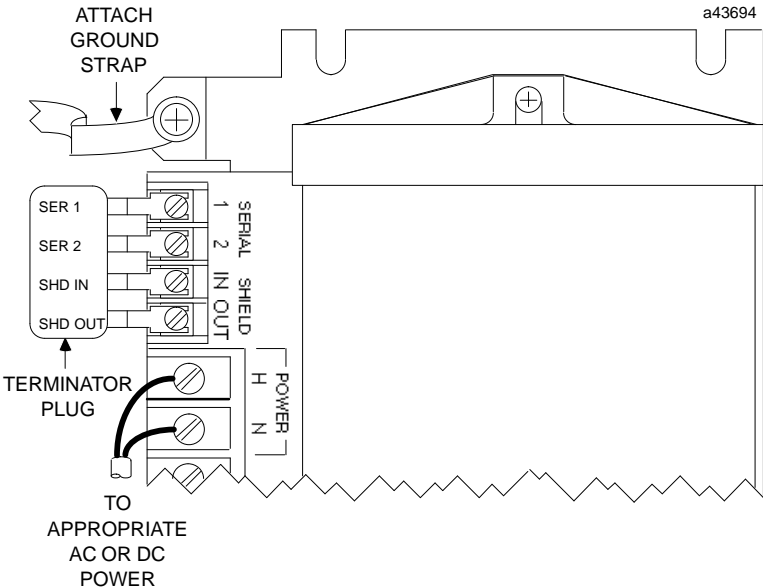

### Note

When the PowerTRAC block is used as a stand-alone device, its I/O Enabled LED remains off. This is normal. The I/O Enabled LED lights only if the PowerTRAC block is receiving outputs from a bus controller.

Configure the block using a Hand-held Monitor, following the instructions in chapter 3. Even though the block will not be used on a bus, it must be given a Device Number. Other options can be selected to suit the application.

If a Hand-held Monitor will be used only with a stand-alone PowerTRAC Block, the HHM can be set up for PCIM host operation. In that mode, the HHM will not expect the block to have a Reference Number.

If the Hand-held Monitor used with a stand-alone block will also be used with a host PLC, as a convenience, the block can be configured to have a Reference Number that is suitable for that PLC type, and the same baud rate used by other devices. The HHM can then communicate with the stand-alone block without needing to change the HHM's host CPU type or baud rate.

## Block Power Wiring

Power wiring connections may be made with wire sizes up to #10. The terminals will accept bare wires, or spade or ring lugs.

Block power may be from a 115/230 VAC or 125 VDC power source.

The same terminals are used for power connections from either an AC or a DC source. For AC power, connect the hot (black) wire to the block's H terminal. Connect the neutral (white) wire to the N terminal. For DC power, connect the DC+ wire to the H terminal. Connect the DC- wire to the N terminal.

Do not apply power to the block before completing the rest of the installation steps.

## Block Grounding

Complete the power wiring by attaching the ground wire to one of the ground screws on the block.

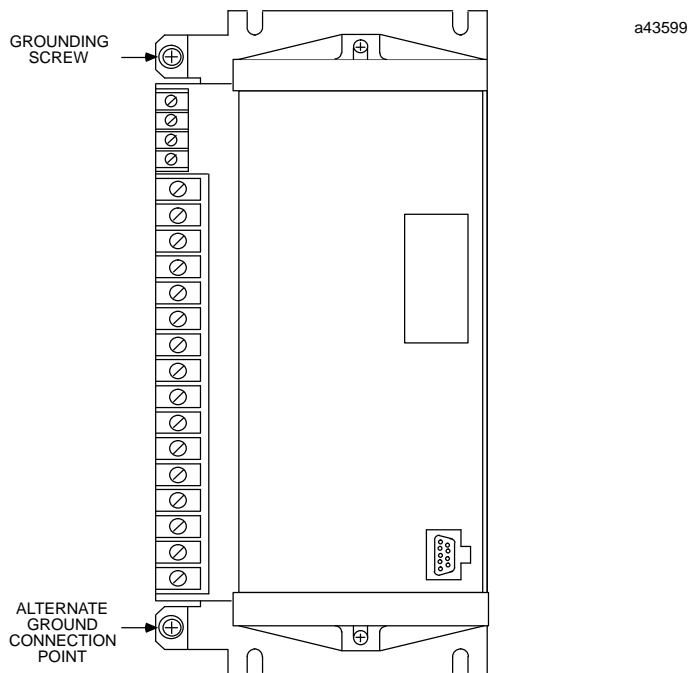

One of the block's ground screws must also be wired to the equipment chassis to ensure proper grounding.

## Wiring from PTs and CTs

Wiring connections from PTs and CTs may be made with wire sizes up to #10. The terminals will accept bare wires, or spade or ring lugs. If conduit will be used to bring wires or cables to the block, its size and installation should be in accordance with local electrical code. For safety, current transformer burdens are permanently connected across the block's current transformer input terminals. No spring-type contacts are used.

Power must NOT be applied to the PowerTRAC block or input terminals when completing the field wiring.

For correct calculation of power values, PTs and CTs must be connected to the power phases and to the block as shown in the following diagrams. **For PTs, the primary and secondary connections should be made the same way (either line-to-line or line-to-neutral) .**

### Required Connections

<b>Number of PTs (L-N)</b>	three	A - N	B - A	C - N
	two	A - N		C - N
	one		B - N	
<b>Number of PTs (L-L)</b>	three	B - C	C - A	A - B
	two	B - C		A - B
	one		C - A	
<b>Number of CTs</b>	three	phase A	phase B	phase C
	two	phase A		phase C
	one		phase B	

If the PTs and/or CTs cannot be connected to the power phases as shown, turn to appendix A.

### Connection to Monitor Current Only

The block can be used to monitor only current, without also monitoring voltage. However, to operate properly, the block needs at least one voltage input. If the block will be used to monitor current only, refer to appendix C for installation and configuration instructions.

### Connections to Other Instrumentation

The PowerTRAC block does not require dedicated PTs and CTs. The PT inputs can be wired in parallel with other instrumentation. The CT inputs can be wired in series with other instrumentation. The total burdens of all instruments including the PowerTRAC block must not exceed the PT or CT ratings.

## Power Flow

Transformers should be connected to the block with the dots as shown in the wiring diagrams. If this is done, power flow in the direction indicated by the arrow in each illustration will provide a + reading for that input.

**Warning**

**For personal safety, PT AND CT SECONDARIES MUST BE GROUNDED.  
Recommended grounding is shown in the diagrams that follow.**

## PT Connections: Line-to-Neutral PTs

Refer to the following example to connect line-to-neutral PTs to the PowerTRAC block. For proper calculation of power values, the block's R, S, and T terminals must be connected to these line-to-neutral PTs:

R terminals:	Phase A to neutral PT
S terminals:	Phase B to neutral PT
T terminals:	Phase C to neutral PT

If there are just two line-to-neutral PTs, one PT must be connected from phase A to neutral and to the block's R terminals. The other must be connected from phase C to neutral, and to the block's T terminals; eliminate S. The PowerTRAC block will synthesize the third voltage (S inputs) from R and T by assuming that  $R + S + T = 0$  at each sample period.

If there is just one PT, it must be connected from Phase B to neutral, and to the PowerTRAC block's S terminals. Do not use R and T. The block will synthesize the other voltages as explained above.

Short any unused inputs together or to ground.

If there are one or two PTs and they cannot be connected to power as shown, refer to appendix A for wiring information.

The PT inputs can be wired in parallel with other instrumentation. The total burdens of all instruments including the PowerTRAC block must not exceed the PT or CT ratings.

## Line-to-Neutral Potential Transformers

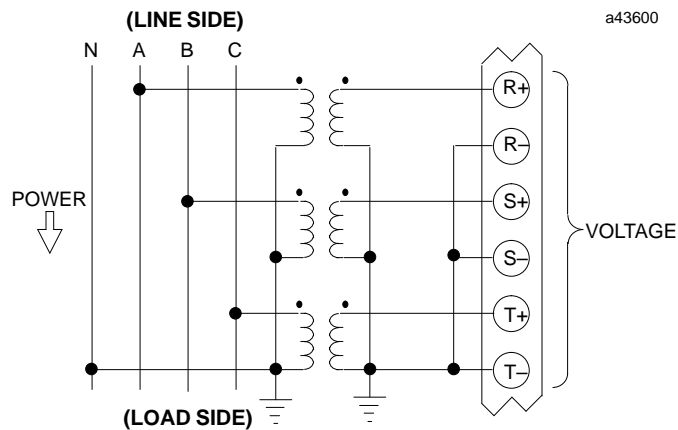

## PT Connections: Line-to-Line PTs

Connections for line-to-line PTs are shown by the examples below. If PTs cannot be connected to power as shown, refer to appendix A for wiring information.

### 3 Line-to-Line Potential Transformers

For proper calculation of power values, the block's R, S, and T terminals must be connected to these line-to-line PTs:

- R terminals: Phase B to phase C PT
- S terminals: Phase C to phase A PT
- T terminals: Phase A to phase B PT

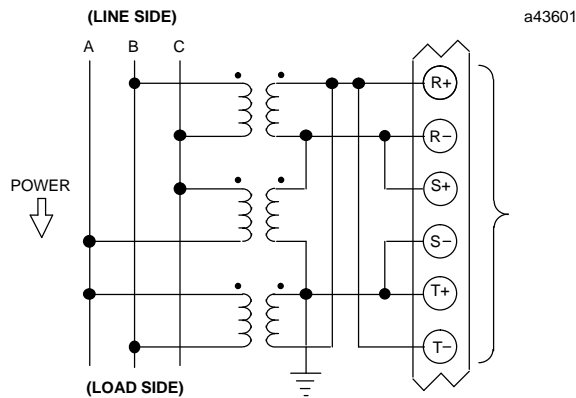

### 2 Line-to-Line Potential Transformers

If there are just two line-to-line PTs, one PT must be connected from phase B to phase C and to the block's R terminals. The other must be connected from phase A to phase B, and to the block's T terminals. Connect the S terminals as shown.

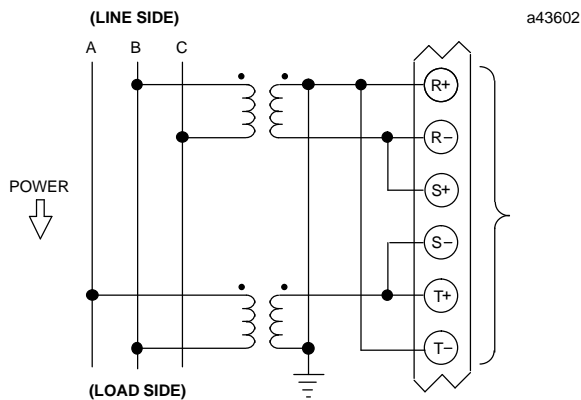



## 1 Line-to-Line Potential Transformer

If there is just one PT, it must be connected from phase C to phase A, and to the PowerTRAC block's S terminals. Do not use R and T.

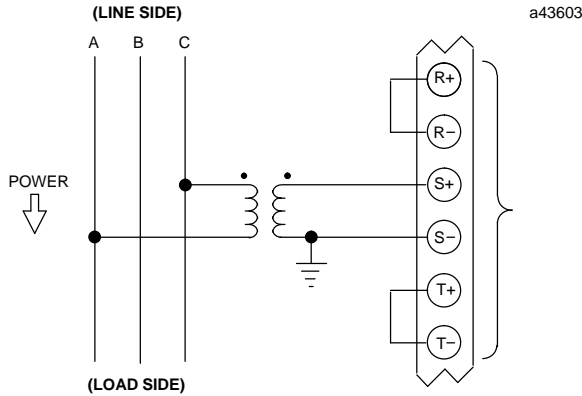

## CTConnections

Refer to the following example to connect CTs to the PowerTRAC block. For proper calculation of power values, the block's A, B, and C terminals must be connected to these CTs:

A terminals:	Phase A
B terminals:	Phase B
B terminals:	Phase C

The CT inputs can be wired in series with other instrumentation. The total burdens of all instruments including the PowerTRAC block must not exceed the PT or CT ratings.

## 3 Line Current Transformers

### 1 Neutral Current Transformer

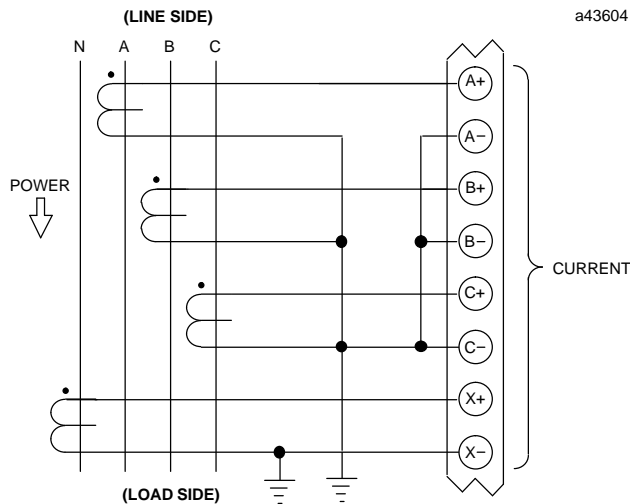

## 2 Line Current Transformers 1 Neutral Current Transformer

If there are just two CTs, one must be connected from phase A to the block's A terminals. The other must be connected from phase C to the block's C terminals; eliminate B.

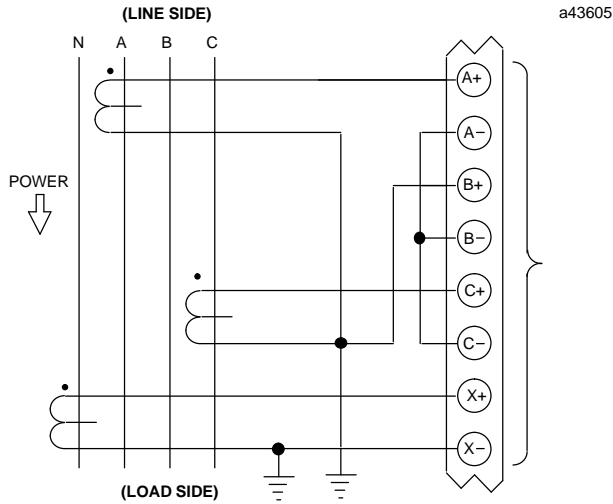

## 1 Line Current Transformer 1 Neutral Current Transformer

If only one CT is used, total power as used in the Watt-hour and Power Factor calculations is assumed to be three times the measured power on phase 2.

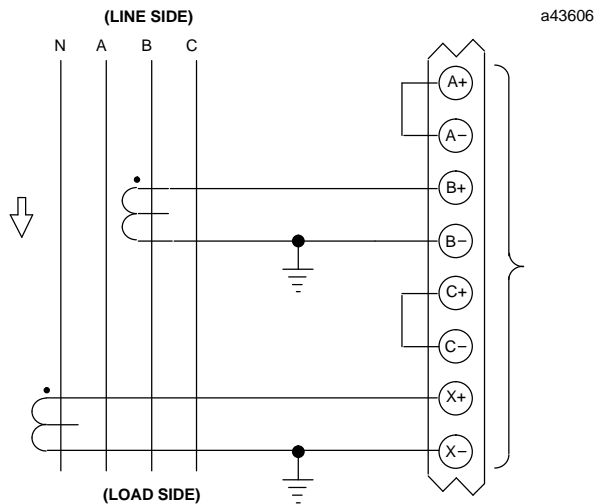

**Caution**

**NEVER disconnect any current transformer wiring from the PowerTRAC block when current is flowing in the primary circuit. The resulting hazardous voltages MAY CAUSE INJURY OR DEATH.**

## Install the Electronics Assembly

The Electronics Assembly and Terminal Assembly are keyed to assure correct installation of the Electronics Assembly.

1. Align the Electronics Assembly, using the shoulder screws on the side of the Terminal Assembly as a guide.
2. Push the Electronics Assembly down quickly.

**Caution**

**Do not exert excessive force. Damage to the equipment can result.**

If unusual resistance is met, remove the Electronics Assembly. Check the keying, and inspect the Terminal Assembly, connector receptacle, and connector edge board on the Electronics Assembly. If necessary, remove any obstacles and reinsert the Electronics Assembly. Pay close attention to the alignment of the guide pins.

3. Secure the Electronics Assembly with the screws on the top and bottom.
4. Apply power to the block. The OK and I/O Enabled LEDs on the front of the Electronics Assembly indicate the status of the block and of the communications bus. Both LEDs should be ON within 2 minutes of receiving power.

OK	I/O Enabled	Meaning
ON	ON	Block functioning CPU communicating
ON	OFF	Block functioning No CPU communications for 3 bus scans
ON	blinking	Data force in effect
blinking	ON	EEPROM failure or other block fault CPU communicating
blinking	OFF	EEPROM failure or other block fault No CPU communications for 3 bus scans
synchronous blinking		No CPU communications-block number conflict
non-synchronous blinking		Device fault and I/O force
OFF	OFF	No power to the block, or block faulty

For information about Genius communications, please refer to the *Genius I/O System User's Manual* (GEK-90486).

### Note

When upgrading firmware, or using the Electronics Assembly to replace an Electronics Assembly that has version 2.2 firmware, it is necessary to reconfigure the block's PT Turns Ratio. If the PT Turns Ratio is less than 10:1, it will be corrected automatically by the PowerTRAC block.

# Chapter 3

## Configuration

---

---

This chapter explains how to configure the PowerTRAC block using a Hand-held Monitor or Write Configuration datagrams.

Note that the configuration of an operating block cannot be changed while it is transmitting waveform or overcurrent data (while output bit 1, "Send Data", is set to 1). For more information, see chapter 6.

### Overview

Each Genius I/O block must be configured to assign it a Device Number for communications on the bus. For some CPU types, each block must also be assigned a Reference Address, which is the beginning memory location in the CPU for the block's inputs and outputs. These features must be configured with a Hand-held Monitor connected directly to the block.

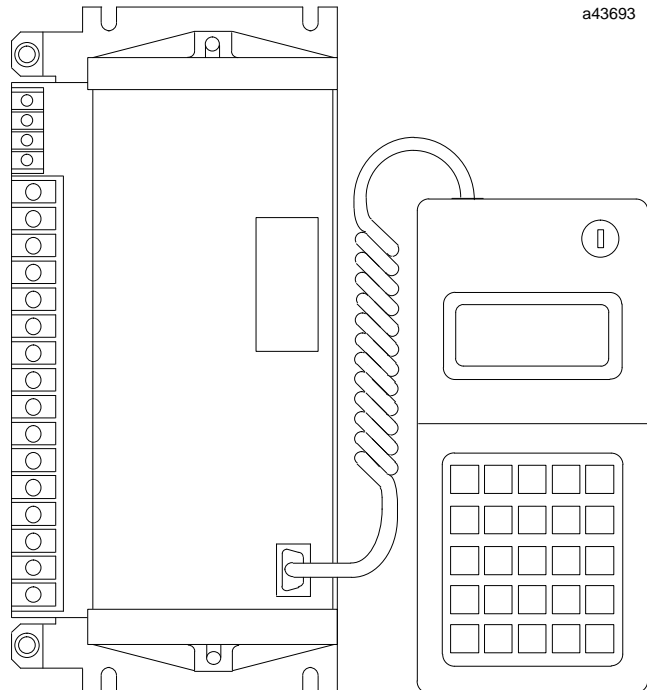

The Hand-held Monitor (IC660HHM501) must be version 3.5 or later (see page 1-12 for more information about HHM/PowerTRAC compatibility). The HHM's Configuration Protection option must be disabled to configure the block.

## Offline HHM Configuration Setup

The block can be configured either while connected to a bus or offline. If the block will be configured offline, it must be set up as described below. *If the block is to be installed on a bus operating at a baud rate other than 153.6 standard, you must configure at least the Device Number and baud rate offline.*

When configuring a block offline, be careful not to assign a Device Number or Reference Address already being used by another device on the same bus where the PowerTRAC block will be installed.

1. Connect a 75-ohm resistor across the block's Serial 1 and Serial 2 terminals. A suitable terminator plug (IC660BLM508) is available.
2. Attach a grounding strap to one of the ground screws on the side of the block. Connect the grounding strap to earth ground.

### Warning

**If the block is not properly grounded, hazardous voltages may exist. Death or injury may result from contact with the block.**

3. Wire the block to an appropriate AC or DC power source, as explained in chapter 2.

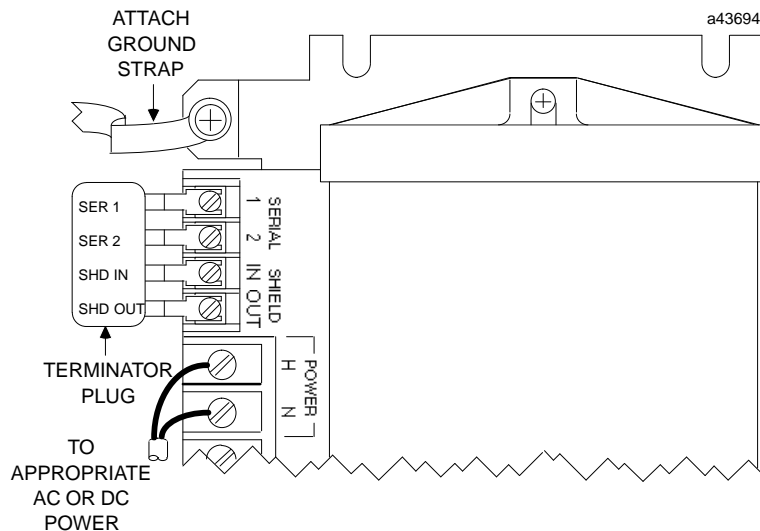

### Warning

**DO NOT TOUCH the connectors or wiring after powering up the block. Hazardous voltages exist, and death or injury may result.**

4. Apply power to the block.

# Select the HHM's Host CPU Type

The same Hand-held Monitor can be used with a Series 90 PLC, a Series Five or Series Six PLC, or a computer-host Genius I/O system. For a new Hand-held Monitor, the default host CPU type is Series Six PLC. If the PowerTRAC Block will be controlled by another type of host, the HHM display format should be changed before continuing with the configuration.

To check or change the HHM's selection for Host CPU type, follow these steps:

1. Turn the Hand-held Monitor ON. After the HHM completes its powerup sequence, a prompt menu to verify the baud rate setting appears. After verifying the baud rate, press F4 (OK) and the Home menu will appear.
2. To change the Hand-held Monitor features, press F1 (HHM Utilities) then F1 (HHM Configure).
3. Press the F4 (Next) key twice to step the display to the Host CPU menu. This screen shows the current host CPU selection:

```
S E L E C T   H O S T   C P U
(current host CPU selection)
```

If the wrong type of host CPU is shown, press the F2 (TGL) key to change the host CPU type. (The HHM keyswitch must be in the CFG position to change this parameter). When the correct host type is displayed, press F3 (Enter).

# Connect the HHM

If the block is on an operating bus, the Hand-held Monitor used for its configuration must be the ONLY Hand-held Monitor currently plugged into a block on the bus.

1. Begin with the Hand-held Monitor turned OFF. Attach the Hand-held Monitor to the block.
2. From the Home menu, select F3 (configuration).

```
F 1 : P R O G   B L O C K   I D
F 2 : C O N F I G   B L O C K
F 3 : C O P Y   C O N F I G
```

## Block ID and Reference Number

The first step in configuring a new PowerTRAC block is to assign its Device Number. For some host types, a Reference Number is also configured with the Hand-held Monitor.

Select F1 (prog block ID). A display like this example will appear.

```

P R O G   B L O C K   I D
I / O           ? -           ? G
B L O C K   N O .   ( I D n u m b e r )
r e f     b l k   e n t r     n x t

```

For some hosts, the Hand-held Monitor may not include the Reference Number field and F1 (ref) key assignment.

BLOCK ID is the block's Device Number on the bus. The Hand-held Monitor is usually assigned Device Number 0. The bus interface block (bus controller) is usually assigned Device Number 31. Other devices are assigned numbers from 1 to 30. Each block is shipped from the factory with an inoperable ID number. A correct number must be assigned before the block can be configured.

Each Device Number assigned must be unique on the bus. When the block is placed on the bus, it will check to be sure its number is not assigned to another device. If it is, the block will not transmit data on the bus until the Device Number is changed.

The REFERENCE NUMBER is the beginning CPU reference address used for the block's status data, calculated values, and command data (for more information, see chapter 4).

1. The Hand-held Monitor must be attached directly to the device where the Device Number is to be programmed. Press F2 (blk) to enter or change the block's Device Number (Block ID). The menu then changes to permit the number to be entered. Enter a number from the keypad, then press the F3 (entr) key. If the selected Device Number is already being used by another device on the bus, the HHM displays an error message. Press the Clear key to clear the display, then repeat the process using a different Device Number.
2. To enter or change the block's Reference Number, press F1 (ref). The menu changes to allow a reference type and number to be entered. The number you enter must be appropriate for the CPU. After entering the number, press F3 (entr). If the selected reference number is already being used by another device on the bus, the HHM displays an error message. Press the Clear key to clear the display, then repeat the process using a different reference number.
3. Press F4 (nxt) to check the block's currently-configured baud rate, and change it if necessary.

## Baud Rate

The bus will not operate unless all the devices on it are set for the same baud rate. Selections are 153.6 Kbaud standard, 153.6 Kbaud extended, 76.8 Kbaud, or 38.4 Kbaud. By default, the block operates at 153.6 Kbaud (standard). The programmed baud rate does not become active until the PowerTRAC block has been power-cycled.

If the PowerTRAC block is to be installed on a bus operating at a baud rate other than 153.6 Kbaud standard, it will be necessary to program the baud rate before installing the block on the bus. If the block is being configured for the first time, to assign its Device Number the Hand-held Monitor must be operating at 153.6 Kbaud standard. Refer to the information about offline configuration at the start of this chapter.

```
S E L E C T   B A U D   R A T E
A C T I V E = 1 5 3 . 6 K       S T
P R O G     = 1 5 3 . 6 K       S T
           t g l   e n t r   n x t
```

1. If the baud rate shown on line 3 should be changed, press F2 (tgl). Press F3 (entr).
2. If the baud rate is changed while the block is installed on an operating bus, it must be changed for all devices on the bus. After changing the baud rate, cycle power at the same time to all devices on the bus to use the new baud rate. In systems where this is not possible, change the baud rate of all devices before power-cycling any of them.
3. Once these required configuration parameters have been entered, the optional selections can be changed by returning to the Configuration Menu.

## Configuration Menu

To complete the block's configuration using the Hand-held Monitor, press Menu, then F2 (configure block).

```
F 1 : P R O G   B L O C K   I D
F 2 : C O N F I G   B L O C K
F 3 : C O P Y    C O N F I G
```



## Block Features

The features listed below can be configured using the Hand-held Monitor, or by using Write Configuration datagrams from the application program.

### Default Configuration

Some configurable features have a default configuration, which will be suitable for many applications and will not need to be changed.

Feature	Selections	Default
PT Connection	line to line, line to neutral	L-N
Number of PTs	1 - 3	3
Number of CTs	1 - 3	2
Power Display Units	Watts, MegaWatts, KiloWatts	KWatts
PT Turns Ratio	1.0 to 2730.0	60.0
CT Turns Ratio	1 to 6550	200
NCT Turns Ratio	1 to 655	5
Current Line Transient	up to 32767A	3276
Auxiliary Current Transient	up to 4600A	327
Sign for VARs and Power Factor	Mode A or Mode B	Mode A
Send Extended Calculated Data	no, yes	no
Baud Rate	153.6 st, 153.6 ex, 76.8, 38.4 Kbaud	153.6 st
BSM Present	yes/no	no
CPU Redundancy	none, hot standby	none
Config. Protect	enabled/disabled	disabled

### HHM Configuration Steps

When Block Configuration is selected, a sequence of HHM displays appears for configuring these features. Configuration steps are described below in the same order as these displays.

### PT Connection

The block can be connected to potential transformers either line-to-neutral or line-to-line. Default is line-to-neutral.

```
P T   C O N N E C T I O N
L - N = 0       L - L = 1
                                     1
r n g   c h n g                               n x t
```

On this and the following configuration screens, pressing F1 (rng) will display the range of configurable entries. After pressing F1, press any function key or the Menu key to return to the same configuration screen.

The number (0 or 1) on line 3 shows whether potential transformers are connected line-to-neutral (0) or line-to-line (1).

- 1. If the number shown should be changed, press F2 (chng).
- 2. Enter the number 0 or 1 from the keypad. Press F3 (entr).
- 3. Press F4 (nxt) to display the next configuration screen.

## Number of PTs

Specify the number of PTs that will be connected to the block (1 to 3). The default is 3.

```
NUMBER OF P T S
( 1   T O   3 )
                                3
r n g   c h n g                   n x t
```

1. If the number on line 3 should be changed, press F2 (chg).
2. Enter the correct number from the keypad. Press F3 (entr).
3. Press F4 (nxt) to display the next configuration screen.

## Number of CTs

Next, specify the number of current transformers (not including an optional neutral current transformer) that will be connected to the block (1 to 3). The default selection is 2.

```
NUMBER OF C T S
( 1   T O   3 )
                                2
r n g   c h n g                   n x t
```

1. If the number on line 3 should be changed, press F2 (chg).
2. Enter the correct number from the keypad. Press F3 (entr).
3. Press F4 (nxt) to display the next configuration screen.

## Power Display Units

The block can report power measurements as Watts, KiloWatts, or MegaWatts. The selection made here will also be used for Vars, KiloVars, or MegaVars, and for Watt Hours, Kilowatt Hours, or Megawatt Hours. The default units are KiloWatts/Kilovars/KilowattHours.

The range for configured units is -32768 to +32767. If Watts are selected, the block will calculate values from -32768 to +32767 Watts.

If KiloWatts are selected, the block will calculate values from -32768Kw to +32767Kw (-32768000 to +32767000 Watts, in 1,000-Watt increments).

If MegaWatts are selected, the block will calculate values from -32768Mw to +32767Mw (-32768000000 to +32767000000 Watts, in 1,000,000-Watt increments).

### Note

The units selected should be sufficient for the block to calculate active power (Power Factor X Volts X Amps) and reactive power without an overflow occurring. Because the scaling selected here determines the resolution of some calculated data, you should select the lowest power display units possible.

```
P W R   D I S P L A Y   U N I T
W = 0 ,   K W = 1 ,   M W = 2
                                     0
r n g   c h n g                       n x t
```

1. If the number (0, 1, or 2) shown on line 3 should be changed, press the F2 (chng) key.
2. Enter the correct number from the keypad. Press the F3 (entr) key.
3. Press F4 (nxt) to display the next configuration screen.

## PT Turns Ratio

The block must know the PT turns ratio to calculate line voltage for PTs. The default is 60.0:1, represented on the HHM screen by the number 60.0. The range of entries is up to 1.0:1 to 2730.0:1 (327670.0:120). For PTs with a higher turns ratio, refer to appendix B for instructions.

If a PT Turns Ratio greater than 273.0:1 is configured, the block will calculate and report voltage in kilovolts, with 1/100's resolution.

```
PT  TURNS  RATIO
( 1 . 0  T O  2 7 3 0 . 0 )
                                     6 0 . 0
r n g   c h n g                               n x t
```

1. If the turns ratio shown on line 3 should be changed, press F2 (chn g).
2. Enter the correct number from the keypad. Press F3 (entr).
3. Press F4 (nxt) to display the next configuration screen.

### Note

If PowerTRAC block firmware version 2.2 or earlier is upgraded (or an Electronics Assembly having that firmware is replaced with a later version), it is necessary to reconfigure the block's PT Turns Ratio. If the PT Turns Ratio is less than 10:1, it will be corrected automatically by the PowerTRAC block.

## CT Turns Ratio

The block must know the turns ratio of the CTs to calculate line current for CTs. The default CT turns ratio is 200:1 (1000:5), which is represented on the Hand-held Monitor screen by the number 200. The range of entries is 1:1 to 6550:1 (32750:5) maximum\*. For CTs with a higher turns ratio, refer to appendix B for instructions.

```

C T   T U R N S   R A T I O
      ( 1   T O   6 5 5 0 )
                                     2 0 0
r n g   c h n g                       n x t

```

1. If the number on line 3 should be changed, press F2 (chng).
2. Enter the correct number from the keypad. Press F3 (entr).
3. Press F4 (nxt) to display the next configuration screen.

### Note

If a CT Turns Ratio up to and including 655:1 is configured, the data will be reported in tenths of Amps.

If a CT Turns Ratio greater than 655:1 is configured, the data will be reported in whole Amps instead.

## NCT Turns Ratio

If there is a neutral current transformer, its turns ratio must also be specified. The default turns ratio is 5:1 (25:5). It would be represented on the Hand-held Monitor screen by the number 5. The range is up to 655:1 (3275:5) \*.

1. If the number shown on line 3 should be changed, press the F2 (chng) key.
2. Enter the correct number from the keypad. Press the F3 (entr) key.
3. Press F4 (nxt) to display the next configuration screen.

```

N C T   T U R N S   R A T I O
      ( 1   T O   6 5 5 )
                                               5
r n g   c h n g                       n x t

```

### Note

If an NCT Turns Ratio up to and including 65:1 is configured, the data will be reported in hundredths of Amps.

If a CT Turns Ratio greater than 65:1 is configured, the data will be reported in tenths of Amps instead.

\* For PowerTRAC blocks prior to version IC660BPM100F (firmware version 3.0), the maximum CT Turns Ratio is 655:1, and the maximum NCT Turns Ratio is 65:1.

### Current Line Transient

The overcurrent threshold represents amperes of instantaneous current on the current transformers. If a current transient above this threshold occurs, the block will store the waveform present on all seven inputs for the three preceding and five subsequent cycles, and inform the host that an overcurrent event has occurred. The default CT line overcurrent level is 3276 amperes. The range is up to 32767 amperes\*.

```
I   l i n e   T R A N S I E N T
      ( 1   T O   3 2 7 6 7 A )
                                3 2 7 6
r n g   c h n g                               n x t
```

1. If the overcurrent level shown on line 3 should be changed, press F2 (chng).
2. Enter the correct number from the keypad. Press F3 (entr).
3. Press F4 (nxt) to display the next configuration screen.

### Auxiliary Current Transient

This overcurrent threshold represents amperes of instantaneous current on a neutral current transformer. If a current transient above this threshold occurs, the block will store the waveform present on all seven inputs for the three preceding and five subsequent cycles, and inform the host that an overcurrent event has occurred. The default NCT line overcurrent level is 327 amperes. The range is up to 4600 amperes\*\*.

```
I   a u x   T R A N S I E N T
      ( 1   T O   4 6 0 0 A )
                                3 2 7
r n g   c h n g                               n x t
```

1. If the auxiliary overcurrent level shown on line 3 should be changed, press F2 (chng).
2. Enter the correct number from the keypad. Press F3 (entr).
3. Press F4 (nxt) to display the next configuration screen.

\* For PowerTRAC blocks prior to version 2.5, the peak current line transient was 4500 Amps.  
\*\* For PowerTRAC blocks prior to version 2.5, the peak aux. current transient was 450 Amps.

## Sign for VARs and Power Factor

The block's sign conventions can be configured. For most systems, the default sign conventions (Mode A) are appropriate.

```

V A R / P F   S I G N   C O N V
M O D E :     A = 0   B = 1
                                     0
r n g   c h n g           n x t
    
```

1. To change the selection on line 3 of the display (0 for no, 1 for yes), press F2 (chng).
2. Enter the correct number from the keypad. Press F3 (entr).
3. Press F4 (nxt) to display the next configuration screen.

### Mode A Configuration (0 on display)

**Sign of VARs:** The block associates +VARs with capacitive circuits (current leads voltage) and - VARs with inductive circuits (current lags voltage).

**Sign of Power Factor:** The sign of Power Factor is based only on the direction of power flow.

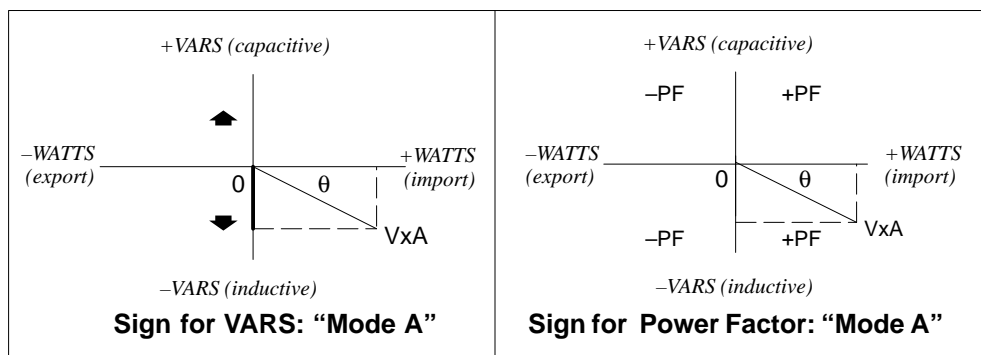

### Mode B Configuration (1 on display)

**Sign for VARs:** The block associates +VARs with inductive circuits and -VARs with capacitive circuits.

**Sign for Power Factor:** The sign of Power Factor is based on the relationship among the direction of power flow, the phase angle (capacitive or inductive) and the load. Power Factor is positive if power is being received and the circuit is inductive (VARs are being imported), or if power is being delivered to the load and the circuit is capacitive (VARs are being exported). Power Factor is negative if power is being imported and the circuit is capacitive or if power is being exported and the circuit is inductive.

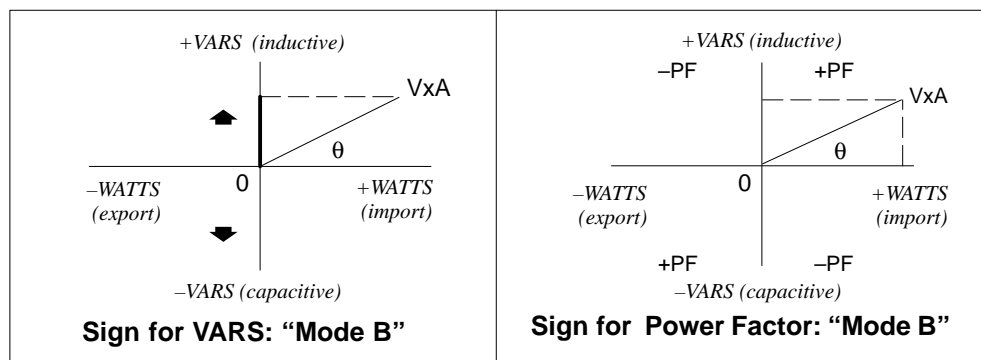



## Send Extra Calculated Data

The PowerTRAC block calculates, but does not automatically sent out, the following data about the application:

- Fundamental (phase shift) VARs for each phase
- Harmonic VARs as a percent of V-A for each phase
- Total harmonic VARs as a percent of V-A
- Line frequency for each phase
- Temperature alarm for the PowerTRAC block
- Extended Watthour accumulator

This data is always displayable on a Hand-held Monitor (version 4.0 or later). By default, it is NOT ordinarily provided to the CPU, and is not assigned reference addresses. However, if your application requires this data regularly, the block's configuration can be changed to enable sending the data each bus scan. Alternatively, the extra data could be requested on an as-needed basis using datagrams, as described in chapter 5.

```

S E N D   E X T R A   D A T A
M O D E :   0 = N O   1 = Y E S
                                     0
r n g   c h n g           n x t

```

1. To change the selection represented on line 3 of the display (0 for no, 1 for yes), press F2 (chg).
2. Enter the correct number from the keypad. Press F3 (entr).
3. Press F4 (nxt) to display the next configuration screen.

### Note

If you re-configure this feature while the PowerTRAC block is online, you should expect the block to stop communicating on the bus for approximately 1.5 seconds. This temporary loss of communications is noted on a Hand-held Monitor as a "Communications Error".

## Configuration Note for the Series 90-70 PLC

If the block is controlled by a Series 90-70 PLC, it is important to match the "broadcast data length" to the length configured using the programming software. Changing this option changes the %AI data length required for the block. If set to NO, the PowerTRAC block uses 18 %AI references. If set to YES, the block uses 30 %AI references.

If the programming software is version 5.0 or earlier, configure a PowerTRAC that has been set up to send the extra data as "GenericI/O" with %I length of 16, %AI length of 30, %Q length of 16 and %AQ length of 0. A later version of the programming software will provide suitable PowerTRAC selections.

### BSM Present

The next screen indicates whether the block is wired downline from a dual serial bus via a bus switching device. The default configuration is NO.

```
B S M   P R E S E N T   ?  
R E F S   ( n u m b e r )  
S T A T U S   = N O  
           t g l   e n t r   n x t
```

- 1. If the selection should be changed, press F2 (tgl). Press F3 (entr).
- 2. Press F4 (nxt) to display the next configuration screen.

### BSM Controller

If BSM Present status is set to YES, the BSM Controller screen is displayed. This screen is used to specify whether a device will function as the BSM Controller (controlling bus selection on a dual bus). For the PowerTRAC block, it should always be set to NO.

```
B S M   C O N T R O L L E R ?  
R E F S   ( n u m b e r )  
S T A T U S   = N O  
           t g l   e n t r   n x t
```

Press F4 (nxt) to display the next configuration screen.

## CPU Redundancy

If the PowerTRAC block will be used on the same bus with two controllers (PLCs or host computers), each of which will send it outputs, the block must be set up for CPU Redundancy. For a new PowerTRAC block as shipped from the factory, this feature is not enabled. If Hot Standby Redundancy is selected, the block will receive outputs from two controllers which have been assigned Device Numbers 30 and 31. The block will use the outputs received from Device Number 30 only if Device 31 stops sending outputs or communications with device 31 are otherwise disrupted.

```

C P U   R E D U N D A N C Y
R E F S (number)
N O   C N T L   R E D U N
           t g l   e n t r   n x t

```

1. If the selection shown on line 3 should be changed, press F2 (tgl). Do not select "Duplex", it is not suitable for this block. Press F3 (entr).
2. Press F4 (nxt) to display the next configuration screen.

## Configuration Protection

This feature can be used to protect the block's configuration, preventing changes from the CPU or Hand-held Monitor. It can only be selected from the Hand-held Monitor. To make subsequent changes, protection must be removed again using the Hand-held Monitor. Before the block is used, its configuration should be protected.

```

C O N F I G   P R O T E C T
R E F S (number)
D I S A B L E D
           t g l   e n t r   n x t

```

1. If the selection shown on line 3 should be changed, press F2 (tgl). Press F3 (entr).
2. This is the last configuration screen.

## Finishing Configuration

That completes configuration of the PowerTRAC block. The new configuration entries are stored in EPROM memory in the block's Terminal Assembly. The configuration will be saved through loss of power.

If the baud rate for the block was changed, and the block is on an operating bus, cycle power to all devices on the bus at the same time to activate the new baud rate.

When any configuration parameter is changed, the PowerTRAC Module resets the watt-hour accumulator to 0.

# Configuration Datagrams for the PowerTRAC Block

After the initial block setup using a Hand-held Monitor, configurable features can be changed using Datagrams. For more information about datagrams, see the *Genius System and Communications Manual* (GEK-90486-2).

Configuration data format for PowerTRAC blocks is listed below. For more information about configurable features, refer to the pages listed.

By specifying an offset, as listed in the left column, and a length in bytes, any portion of the configuration data can be read or written. If more than 16 bytes are being read or written, data is transmitted in multiple bus scans up to 16 bytes at a time.

## Configuration Data Format

Offset (Byte #)	Byte Description	Page Number for More Information
0 1	Block type READ ONLY Software revision number READ ONLY	3-18
2, 3	Block Configuration	3-18
4 5	Input Data length in bytes (38 (default) or 62 if byte 28 is set to 1) Output Data length in bytes (always 2)	
6 7	Configuration Data length in bytes (always 30) Diagnostic Data length in bytes (always 4)	
8 9	Potential Transformer Connection (0=L-L, 1=L-N) not used	3-7
10 11	Number of Potential Transformers (1-3) not used	3-8
12 13	Number of Current Transformers (1-3) not used	3-8
14 15	Power Display Units (0 = Watts, 1 = kW, 2 = MW) not used	3-9
16, 17	PT Turns Ratio (1.0 to 2730.0 (:1)). (Lsb in byte 16, msb in byte 17)	3-10
18, 19	CT Turns Ratio (1 to 6550 (:1))	3-11
20, 21	NCT Turns Ratio (1 to 655 (:1))	3-11
22, 23	Current Line Transient (1 to 32767A)	3-12
24, 25	Aux. Current Transient (1 to 4600A)	3-12
26 27	Sign for VARS and Power Factor (Mode A = 0, Mode B = 1) not used	3-13
28 29	Send Extra Calculated Data (No = 0, Yes = 1) not used	3-14

### Block Type (byte 0)

<u>Block Type</u>	<u>Catalog Number</u>	<u>Decimal</u>
PowerTRAC Block	(IC660BPM100)	127

### Block Configuration (bytes 2, 3)

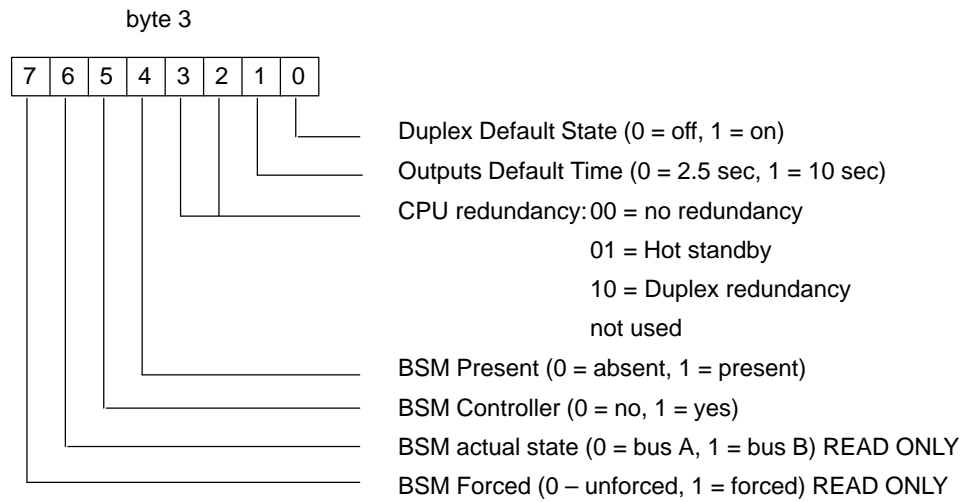
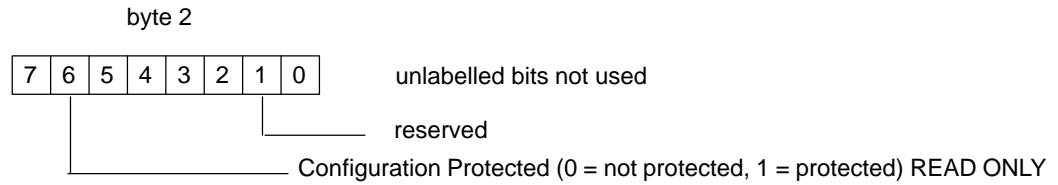

# Chapter 4

## Calculated Data and Status Data

This chapter explains how to access and interpret data which is automatically transmitted to and from a PowerTRAC block. It covers the following topics:

- Automatic data transfer
- Bus scan times
- CPU interface
- Displaying data with a Hand-held Monitor
- Status inputs
- Calculated values
- Command outputs

### Automatic Data Transfer

Once each bus scan, the PowerTRAC block automatically broadcasts the following 18 words (36 bytes) of calculated data and 1 word (2 bytes) of status data.

Byte No.	Bit Nos.	Description
0, 1	1 - 16	Status inputs
2, 3	17 - 32	Voltage, phase A to B
4, 5	33 - 48	Voltage, phase B to C
6, 7	49 - 64	Voltage, phase C to A
8, 9	65 - 80	Voltage, phase A to neutral
10, 11	81 - 96	Voltage, phase B to neutral
12, 13	97 - 112	Voltage, phase C to neutral
14, 15	113 - 128	Current, phase A
16, 17	129 - 144	Current, phase B
18, 19	145 - 160	Current, phase C
20, 21	161 - 176	Current, auxiliary
22, 23	177 - 192	Active power, phase A
24, 25	193 - 208	Active power, phase B
26, 27	209 - 224	Active power, phase C
28, 29	225 - 240	Reactive power, phase A
30, 31	241 - 256	Reactive power, phase B
32, 33	257 - 272	Reactive power, phase C
34, 35	273 - 288	Total power factor
36, 37	289 - 304	Total Watt/Kilowatt/Megawatt-hours

The data is received by the host, and stored in the block's assigned input references. Because this data is broadcast, other devices on the bus can also monitor the block's inputs.

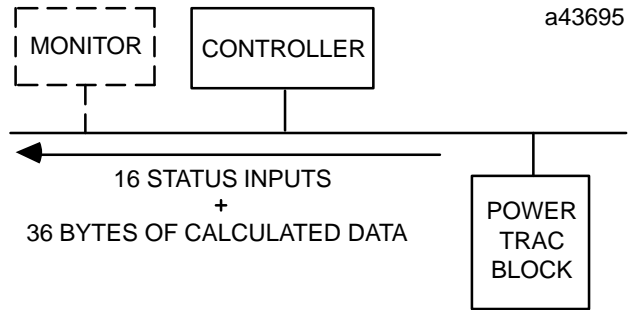

When the host has its turn on the bus, it directs 16 bits of control data from the application program to the block. Only the host can send outputs to the block; a monitoring device cannot.

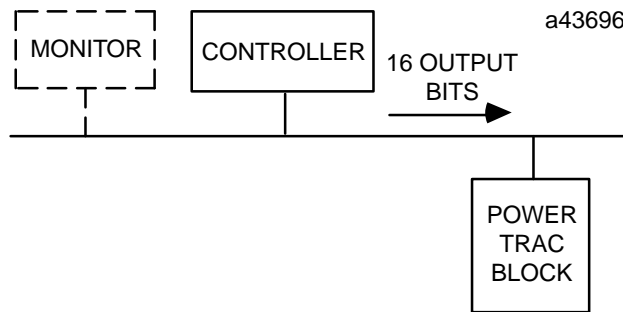

Use of this output data is optional. The application program logic can set or clear output bits to set up a communications "handshake" between the block and the CPU, required for reading Working Data or Overcurrent Data. This data can also be displayed on a Hand-held Monitor, but is not available to any other devices on the bus. If the application does not require the use of this data, these bits should ALWAYS be set to 0.

### CPU Memory Usage

A device controlling a PowerTRAC block must reserve memory space for its status inputs, calculated values and command outputs. If the "Send Extra Data" function (as described on page 3-14) is not enabled for a PowerTRAC block, it uses 304 input references (bits) and 16 output references. If the "Send Extra Data" function is enabled for a PowerTRAC block, it uses 496 input references (bits) and 16 output references. Different controllers handle this data as explained below:

#### Series 90 PLC

When a PowerTRAC block's Reference Number is assigned using Logicismaster 90 release 3.02 or later, separate starting addresses can be selected. If the block is not configured to "Send Extra Data", it requires 16 %I input bits, 16 %Q output bits, and 18 %AI references. If the block is configured to "Send Extra Data", it requires 16 %I input bits, 16 %Q output bits (as above), and 30 %AI references. Note that separate starting references will *not* be displayed on a Hand-held Monitor. If an earlier version of Logicismaster is used, all three

data types must use the same starting address (for example, %I0001, %Q0001, and %AI0001).

**Series Six  
PLC**

A block can be assigned either an I/O or register Reference Number in the Series Six PLC. If the block is assigned to I/O memory, it will use 24 input references and 16 output references. As an example, if the Reference Number I/O0001 were assigned, the block's status inputs and calculated values would occupy I0001 through I0024. The command outputs would occupy O0001 through O0016. If the "Send Extra Data" function is not enabled for a PowerTRAC block, it sends 38 bytes of status and calculated data to the bus controller each bus scan. If the "Send Extra Data" function is enabled for a PowerTRAC block, it sends 62 bytes of status and calculated data to the bus controller each bus scan.

The Series Six bus controller stores this information, sending 24 bits at a time to the CPU. The bus controller multiplexes these values in the same 24 Input Table references. The first 16 bits contains one data item: first the Status Inputs, then the A/B Voltage, then the B/C Voltage, and so on. The entire data transfer takes 19 successive CPU sweeps if the "Send Extra Data" feature is NOT enabled, or 31 CPU sweeps if it is enabled. The uppermost 8 bits contain the data item number currently available. The program must include logic to capture each value before it is replaced by the next one. Alternatively, the application program can read ALL input data from the bus controller at the same time by issuing a Read Analog Inputs command.

Assigning the block to register memory conserves I/O memory space and permits the use of more PowerTRACs on the same bus. If a PowerTRAC block is assigned to register memory it uses 20 registers if "Send Extra Data" is not enabled, or 32 registers if it is enabled. For example, if the Reference Number R0001 were assigned, the block's status inputs would occupy R0001. The calculated values would occupy R0002 through R0019 (or R0031). The command outputs would occupy R0020 (or R0032).

Whether a PowerTRAC block is assigned to I/O or register memory, special programming is always required. For instructions, refer to the *Series Six Bus Controller User's Manual* (GFK-0171).

**Series Five  
PLC**

Either I/O or register references can be assigned to a PowerTRAC block used with a Series Five PLC. See the example Reference Number assignments for the Series Six PLC. If I/O references are assigned, one block's 304 inputs will occupy a significant portion of the available I/O space. This can be avoided by assigning the block to register (global) memory. It will use 20 registers if the "Send Extra Data" feature is NOT enabled, or 32 registers if it is enabled. No special programming is required. Note that the 304 outputs (496 with "Send Extra Data" enabled) that correspond to the block's 304 (or 496) inputs will also be unusable by other applications, even though only the first 16 are actually used by the PowerTRAC block.

**Host  
Computer**

The PCIM in the computer stores inputs in a 128-byte area of on-board shared RAM. The application program can overlay a data structure on this data to distinguish its individual elements. Reference Number assignments are not used by the PCIM.

Status and calculated input data occupy the first 19 data words (31 data words if the PowerTRAC block's "Send Extra Data" feature is enabled) of the 128-byte input area. Command outputs occupy the first word of the 128-byte output area.



## Displaying Data With a Hand-held Monitor

All data automatically transmitted to and from a PowerTRAC block can be displayed on a Hand-held Monitor. Status data is most easily viewed from the Monitor Block displays. Calculated values are most easily viewed from the Monitor/Control Reference displays.

Status data is always displayed first. Pressing F1 ( > ) displays data in the sequence shown in the table below. Specific values may be displayed by pressing F2 (ref), then entering a reference offset. To access output data, press (ref), the desired reference number, and the TGL key to select the memory type.

Value to Display	Data Format
StatusInputs	Binary word
Voltage, phase A to B Voltage, phase B to C Voltage, phase C to A Voltage, phase A to neutral Voltage, phase B to neutral Voltage, phase C to neutral	Signed integer. If PT Turns Ratio is 327.0 or less, range is -32,768 to +32,767 volts. If PT Turns Ratio is above 273.0, range is -327.68 to +327.67 Kv.
Current, phase A Current, phase B Current, phase C	Signed fixed point. If CT Turns Ratio is configured as 655:1 or less, data format is XXXX.X, -3276.8 to +3276.7. If CT Turns Ratio is configured above 655:1, data format is XXXXX, -32768 to +32767.
Current, auxiliary	Signed fixed point. If NCT Turns Ratio is configured as 65:1 or less, data format is XXXX.X, -327.68 to +327.67. If NCT Turns Ratio is configured above 65:1, data format is XX.XXX, -32.768 to +32.767.
Active power, phase A Active power, phase B Active power, phase C	Signed integer, -32,768 to +32,767. Units defined by Hand-held Monitor.
Reactive power, phase A Reactive power, phase B Reactive power, phase C	Signed integer, units defined by Hand-held Monitor.
Total Power Factor	Signed fixed point. Format: +/- X.XXX
Total Watt/Kwatt/Mwatt-hours	Signed integer, units defined by Hand-held Monitor. Range is 0 to 32767.
Commandoutputs	Binary word

Definitions and example Hand-held Monitor displays are given on the following pages.

# Status Inputs

The first 16 input bits are the status inputs.

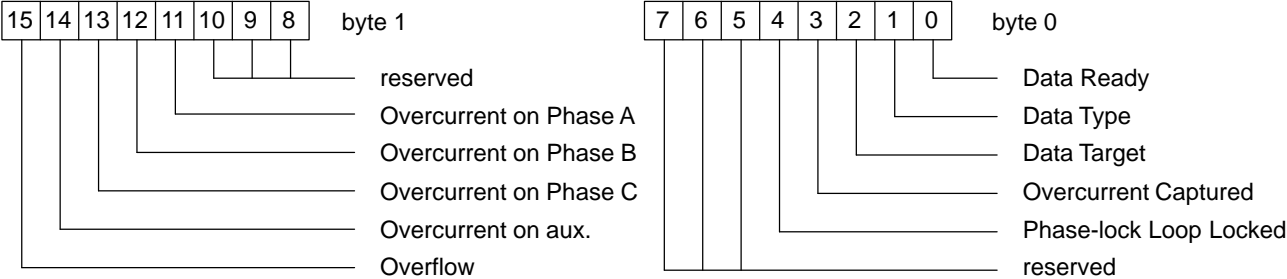

These inputs provide diagnostic information and are used to establish a communications handshake between the PowerTRAC block and the PLC or host computer.

**Overflow** If set, this bit indicates that the block’s voltage, current, active power, or reactive power calculations have resulted in a value outside the range -32768 to +32767. If this happens, a larger unit multiplier should be configured as instructed in chapter 3. If an overflow occurs, the overflowed items are set to minimum or maximum values. When the overflow condition is corrected, this bit is automatically cleared.

**Overcurrent** If one or more of these bits is set, it indicates that the corresponding current input has exceeded its configured safe overcurrent level. The “overcurrent captured” bit is also set.

**Phase-lock Loop Locked** This bit should be always be equal to 1. It indicates whether the block’s phase-lock loop is synchronized with the incoming AC voltage (on any voltage input). If this bit is 0, possible causes are:

- A. AC voltage is too low, or not present.
- B. The PowerTRAC block is faulty.

**Overcurrent Captured** The block sets this bit to 1 when a current transient occurs. The input(s) on which the overcurrent occurred are indicated by the overcurrent bits described above. The application program can issue a Read Device Datagram to read the captured overcurrent data. For information about this and the following three status bits, see chapter 6.

**Data Target** If the controller commands the block (see Command Outputs) to transmit table data, this bit determines whether the data will be read by the CPU (bit = 0), or another device on the bus (bit = 1).

**Data Type** This bit indicates which data table (see above) will be read. If this bit is 0, the block will buffer the contents of the working data table. If this bit is 1, the block will buffer the contents of the overcurrent data table.

**Data Ready** If set, this bit indicates that requested table data has been copied to the block’s transmit buffer and is ready to be read by the CPU or monitoring device.

## Displaying Status Inputs on a Hand-held Monitor

Status inputs can be displayed together on the Monitor Block screen, or individually on the Monitor/Control Reference screens.

### Monitor Block Status Display

The HHM's Monitor Block screen shows all 16 status inputs at the same time. For example:

R E F S	1 -	1 6 I	Z (Series 90 PLC)
1 2 3 4 5 6 7 8 9 0 1 2 3 4 5 6			Z bit numbers
0 0 0 1 1 0 0 0 0 0 0 1 0 0 0 0			Z bits' status
> r e f f o r c e d i a g			

Line 2 represents each of the 16 possible bit locations for status data. Line 3 shows the current status of all inputs. To display status inputs on the Monitor Block screen:

1. From the Home menu, select F2 (analyze).
2. Select F1 (Monitor Block).

From this screen, press F1 (>) or F2 (ref) to display higher references. Calculated data values (such as voltage and current) can be displayed, but the values are not labelled. It is easier to monitor these values from the Monitor/Control References screens.

### Monitor/Control Reference Status Display

The HHM's Monitor/Control Reference screens show the status inputs one at a time. For example:

M N T R / C T R L	1 I	Z (for Series 90 PLC)
S T A T U S I N P U T S		
S T A T E : 0		Z bits' status
> r e f f o r c e d i a g		

Line 1 indicates the bit whose status is currently being displayed. Line 3 displays the bit's status. On the example display shown above, bit 1 status is 0. This example shows that the first status input is currently 0. To display status inputs on the Monitor/Control Reference screen:

1. From the Home menu, select F2 (analyze).
2. Select F2 (Monitor/Control Reference).

From this screen, press F1 (>) to display the other status bits individually. Following the status inputs, the calculated values are displayed.

## Calculated Values

The calculated values are reported as 16-bit twos complement numbers. Active power, reactive power, and power factor are signed, with the sign indicating the direction of power flow.

The Hand-held Monitor displays calculated values on its Monitor Block screens and on its Monitor/Control Reference screens. New values are displayed every 2-3 seconds.

When displayed from the Monitor Block screen, calculated values are not labelled.

To display calculated values on the Hand-held Monitor's Monitor/Control Reference screens:

- From the Home menu, select F2 (analyze).
- Select F2 (Monitor/Control Reference). Screens appear in the sequence shown on the following pages. The first screen to appear is the first status input screen. From the status display, press F1 ( > ) to display successive references or press F2 (ref), and enter the appropriate number as shown previously. Then press F4 (entr).

### Voltage, Line-to-Line

The calculated primary line voltage is a true RMS voltage even if the voltage waveform is distorted. Allowable values are 0 to 327 Kilovolts. Line-to-line voltages are calculated whether the configuration is line-to-line or line-to-neutral.

### Hand-held Monitor Display

The following illustrations show the HHM's Monitor/Control Reference display for phase A to phase B voltage. Phase B to phase C and phase C to phase A voltage are displayed on the next two screens.

If the PT Turns Ratio is between 1.0:1 and 273.0:1 (32767:120), the voltage is displayed on these screens in volts:

```

M N T R      1 7 -      3 2      I
  v a b
S T S                1 1 9
>   r e f   f o r c e   d i a g

```

Z Voltage A to B  
Z volts

If the PT Turns Ratio is greater than 273.0:1, these screens display voltage in kilovolts:

```

M N T R      1 7 -      3 2      I
  v a b   ( K V )
S T S                0 . 1 2
>   r e f   f o r c e   d i a g

```

Z kilovolts

## Voltage, Line to Neutral

Line-to-neutral voltage is a true RMS voltage even if the voltage waveform is distorted. Allowable values are 0 to 327 Kilovolts.

The block will also calculate the line-to-line voltages from the sensed line-to-neutral voltages. If the block is configured for line-to-line PTs, line-to-neutral voltages are not calculated.

## Hand-held Monitor Display

The following illustrations show the HHM's phase A line-to-neutral voltage Monitor Control Reference display. Phase B and phase C line-to-neutral voltage are displayed on the next two screens.

If the PT Turns Ratio is between 1.0:1 and 273.0:1 (32767:120), the voltage is displayed on these screens in volts:

```

M N T R      6 5 -      8 0      I
  V a n
S T S                6 8
>   r e f   f o r c e   d i a g

```

Z Voltage A to N  
Z volts

If the PT Turns Ratio is greater than 273.0:1, these screens display voltage in kilovolts:

```

M N T R      6 5 -      8 0      I
  V a n   ( K V )
S T S                0 . 0 7
>   r e f   f o r c e   d i a g

```

Z Voltage A to N  
Z kilovolts

## Line Current

Line current is a true RMS current even if the current waveform is distorted. If the CT Turns Ratio is configured as 655:1 or less, data is displayed as tenths of Amps (-3276.8 to +3276.7). If the CT Turns Ratio is configured above 655:1, data is displayed as Amps (-32768 to +32767).

### Hand-held Monitor Display

The following illustration shows the HHM's Monitor/Control Reference display for phase A line current. Phase B and phase C and auxiliary current are displayed on the next three screens.

```

M N T R    1 1 3 - 1 2 8    I
  I a
S T S                9 7 . 8
>   r e f   f o r c e   d i a g

```

z Current, phase A  
z calculated value

In the example shown, data is displayed as tenths of Amps, indicating that the CT Turns Ratio has been configured as 655:1 or less.

## Auxiliary Current

The auxiliary current is calculated in amperes. If the NCT Turns Ratio is configured as 65:1 or less, data is displayed as hundredths of Amps (-32.768 to +32.767). If the NCT Turns Ratio is configured above 65:1, data is displayed as tenths of Amps (-327.68 to +327.67).

This input is used to detect a flowing current in an independent line. For example, it can be used to detect current in the neutral leg of a three-phase circuit.

Since auxiliary current input is not included in the power calculations but does support overcurrent detection, it may be used for other monitoring.

### Hand-held Monitor Display

The following illustration represents the HHM's Monitor/Control Reference display of auxiliary current.

```

M N T R    1 6 1 - 1 7 6    I
  I a u x
S T S                3 . 2 2
>   r e f   f o r c e   d i a g

```

z aux. current  
z amperes

In the example shown, data is displayed as hundredths of Amps, indicating that the NCT Turns Ratio has been configured as 65:1 or less.

## Active Power

The active power value represents the amount of real power being monitored. It is calculated approximately twice per second. The calculated active power is the numerical integration of  $V \times A$  over one cycle (128 samples) for either delta or wye configurations. In the following equation,  $V$  is the equivalent line-to-neutral voltage.

$$W = \int V \times A$$

Active power is measured in units of Watts, KiloWatts, or MegaWatts. The unit multiplier is selected when the block is configured. The numeric range for the active power calculation is  $-32768$  to  $+32767$ . If the product of the calculation exceeds either limit, an overflow occurs. The block automatically sets the numeric value to the nearest limit, and sets its Overflow status bit to 1. If this happens, larger units (kiloWatts or megaWatts) should be configured for the block as explained in chapter 3.

The sign of the active power value indicates the direction of power flow. If the sign is positive, power is being delivered to the load. If the sign is negative, power is being fed back into the system (toward the source). Power can be measured in either direction, depending on the polarity of the user connections.

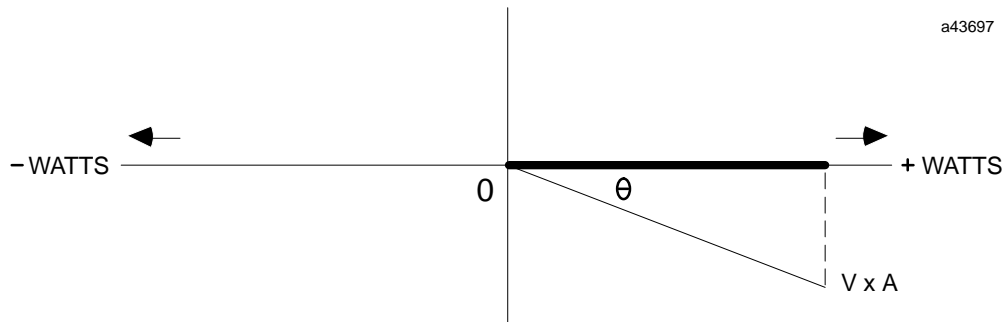

The angle  $\Theta$  represents the amount by which current leads or lags voltage. If current and voltage were in phase, with current neither leading nor lagging voltage, the angle  $\Theta$  would be either  $0^\circ$  or  $180^\circ$ , and Watts would be equal to volts x Amps. When current leads or lags voltage, the angle  $\Theta$  increases and active power is less than the product of volts x Amps.

## Hand-held Monitor Display

The following illustration represents the HHM's Monitor/Control Reference display for phase A active power. Phase B and phase C active power are displayed on the next two screens.

```

M N T R   1 7 7 - 1 9 2   I
P a
S T S           5 6 2 5
>   r e f   f o r c e   d i a g
    
```

- Z Power phase A
- Z calculated value

## Reactive Power

The calculated value for reactive power indicates the amount of non-useful power in the system. It is calculated approximately twice per second. The calculated reactive power is calculated over one cycle (128 samples). In the following equation, V is the equivalent line-to-neutral voltage.

$$\text{VAR}_{\text{TOT}} = ( \text{VA}^2 - \text{W}^2 )$$

Reactive power is measured in VARs, KiloVARs, or MegaVARs. The unit multiplier corresponds to the selection for VARs when the block is configured. For example, if KiloWatts is selected for the active power units, reactive power will be measured in KiloVARs.

The range is -32768 to +32767. The sign indicates whether the system is operating inductively or capacitively. If the sign is positive, the system is capacitive. If the sign is negative, the system is inductive. If the block's reactive power calculations result in a value which is out of range, an overflow occurs. The block sets the reactive power value to its nearest limit, and sets the overflow status input to 1. If that happens, a larger unit multiplier should be configured as explained in chapter 3.

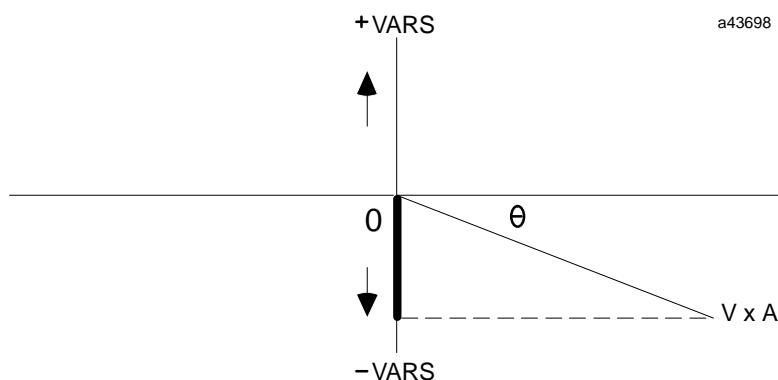

Here also, the angle  $\Theta$  represents the amount by which current leads or lags voltage. If current and voltage were in phase, with current neither leading nor lagging voltage, the angle  $\Theta$  would be either  $0^\circ$  or  $180^\circ$ , and VARs would be equal to 0. When current leads or lags voltage, the angle  $\Theta$  increases and the reactive power value also increases.

## Hand-held Monitor Display

The following illustration represents the HHM's Monitor/Control Reference display for phase A reactive power. Phase B and phase C reactive power are displayed on the next two screens.

```

M N T R      2 2 5 - 2 4 0   I
  V A R a
S T S                2 7 7
>   r e f   f o r c e   d i a g
    
```

Z Units, phase  
Z calculated value



## Power Factor

Power Factor (PF) indicates the relationship between useful power (Watts) and non-useful power (VARs). The block calculates power factor based upon the relative magnitudes of active and reactive power. In the following equation V is the equivalent line-to-neutral voltage.

$$PF_{tot} = \cos \Theta_{tot} = \frac{W}{VA}$$

If both are in phase, angle  $\Theta$  is either  $0^\circ$  or  $180^\circ$ , and power factor is either +1.000 or -1.000. Power factor should be as close to +1 as possible; this would indicate no VARs (no non-useful power). As current increasingly leads or lags voltage, the angle  $\Theta$  increases and power factor decreases. A power factor of 0 would indicate that there was no useful power in the system.

The sign of the power factor indicates the direction of power flow. If the sign is positive, power is being delivered to the load. If the sign is negative, power is being fed back into the system.

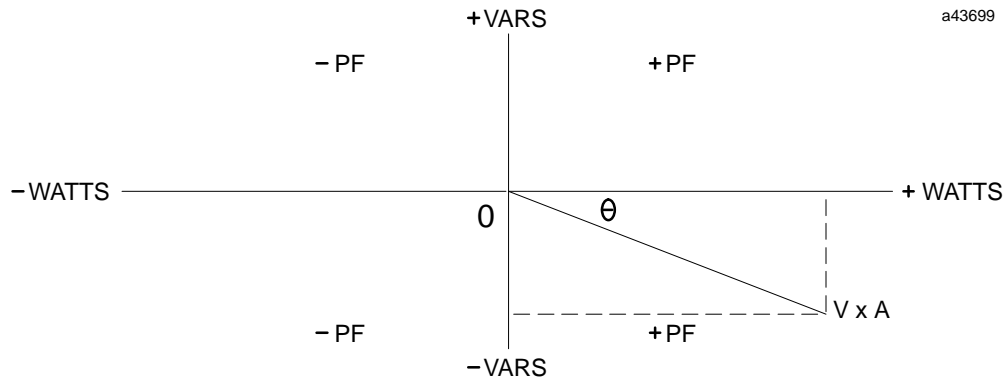

The resolution of the Power Factor data depends on the block's configured Power Display Units. Therefore, it is important to configure the lowest possible Power Display Units. See page 3-9 for information about configuring Power Display Units.

## Hand-held Monitor Display

The following illustration represents the HHM's Monitor Control Reference display of the calculated power factor.

```

M N T R   2 7 3 - 2 8 8   I
P F   T o t a l
S T S       0 . 8 6 4
>   r e f   f o r c e   d i a g
    
```

Z Power factor  
Z calculated value

## Accumulated Power

The PowerTRAC block begins sampling data and calculating current, voltage, and power values as soon as it is turned on. As active power values are calculated, the block adds them to a running total stored in its internal memory. The numeric range for this value is 0 to +32767, which may indicate Watt-hours, KiloWatt-hours, or MegaWatt-hours. The multiplier is the same as that for Watts (see above).

The total accumulated power value can vary either upward or downward depending upon whether power is being consumed or supplied. When either maximum value is reached, the total assumes the greatest opposite value (it goes from 32767 to 0 or from 0 to -32767). It continues to increase or decrease, depending upon the direction of power flow. This event should be captured by logic in the application program.

## Hand-held Monitor Display

The following illustration represents the HHM's Monitor/Control Reference display of total watt-hours. Line 2 indicates Watt-hours, KWH, or MWH, depending on the block's configuration.

```
M N T R    2 8 7 - 3 0 4    I
  W A T T  H O U R S
S T S           5 1 0 2
>   r e f   f o r c e   d i a g
```

Z power units  
Z calculated value

## Command Outputs

Command outputs are automatically sent from the CPU to the PowerTRAC Block. They contain data from the block's assigned output references. Content of these bits is controlled by the application program. *These bits should be set to 0 unless the host controller or data monitoring device are reading table data. After completing the data transfer, all bits should be cleared immediately, competing the handshake.*

Note that these outputs automatically default to 0 if communications with the bus controller are disrupted. \*

### Content of the Command Outputs

Each bus scan, the host bus controller directs the following two bytes of control data to the block. The data is sent from the block's assigned output references:

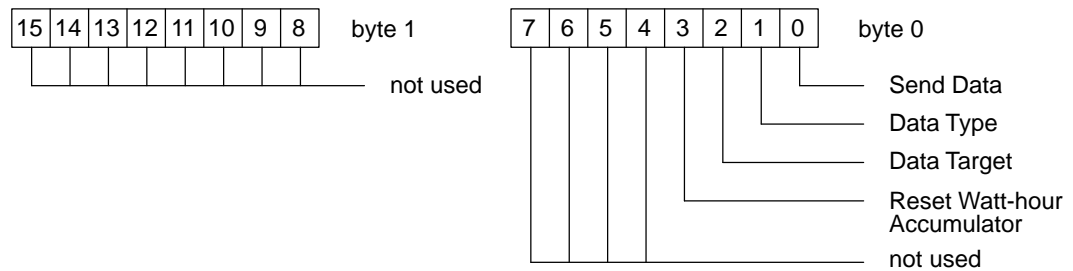

Unlike inputs, which are broadcast by the PowerTRAC block to all devices on the bus, outputs are directed; they may only be sent by the controller CPU, and they may only be received by the block to which they are directed.

Chapter 6 explains how these outputs can be used to set up data transfer between the PowerTRAC block and the controller, or a monitoring device.

**Send Data** The application program can set this bit to 1 to instruct the block to capture and freeze a copy of the data table specified by the Data Type bit. *When this bit is set to 1, block configuration changes are locked out and the captured data table will remain frozen.*

**Data Type** This bit indicates which data table is to be read. If this bit is 0, data from the Working Data Table will be read. If this bit is 1, data from the Overcurrent Data Table will be read.

**Data Target** The program should set this bit to 1 if a monitoring device is to read the specified table.

**Reset Watt-hour Accumulator** This bit can be used to restart the Watt-hour Accumulators. Both the regular and extended Watt-hour Accumulators clear and begin accumulating when this bit transitions from 0 to 1. \*\*

\* PowerTRAC blocks with firmware prior to version 2.5 hold outputs in their last states if communications are disrupted.

\*\* PowerTRAC blocks with firmware prior to version 3.0 do not have this capability.

## HHM Command Outputs Displays

Command outputs can be displayed on the HHM's Monitor Block screen, or on the Monitor/Control Reference screens.

### Monitor Block Display

The HHM's Monitor Block screen shows all 16 command outputs at the same time.

<pre> R E F S      1 -      1 6  Q 1 2 3 4 5 6 7 8 9 0 1 2 3 4 5 6 0 0 0 0 0 0 0 0 0 0 0 0 0 0 0 0 &gt; r e f   f o r c e   d i a g </pre>	<pre> Z (Series 90 PLC) Z bit numbers Z bits' status </pre>
--	---

Line 2 represents each of the 16 possible bit locations for command data. The least significant bit is on the left. Only the three least significant bits are used by the block. Line 3 shows the current status of the bits. To display command outputs on the Monitor Block screen:

1. From the Home menu, select F2 (analyze).
2. Select F1 (Monitor Block). Enter the reference as explained previously.

### Monitor/Control Reference Display

The HHM's Monitor/Control Reference screens show the command outputs one at a time. For example:

<pre> M N T R / C T R L      1  Q C O M M A N D   O U T P U T S S T A T E :   0 &gt; r e f   f o r c e   d i a g </pre>	<pre> Z (for Series 90 PLC) Z bits' status </pre>
---	---

Line 1 indicates the bit whose status is currently being displayed. In this example, where the host computer is a Series 90 PLC, the bit shown is Q0001. Line 3 displays the bit's status. On the example display shown above, bit 1 status is 0.

The next 2 Monitor/Control reference screens show the other command output bits in turn. To display command outputs on the Monitor/Control Reference screen:

1. From the Home menu, select F2 (analyze).
2. Select F1 (Monitor Block). Enter the reference as explained previously.

### Forcing Outputs

Outputs can be forced *regardless of the presence of communications with the bus controller.\**

\* Outputs on PowerTRAC blocks with firmware prior to version 2.5 cannot be forced while the PowerTRAC block is offline or communications with the bus controller are disrupted.

# Chapter 5

## *Additional Calculated Data*

---

---

The PowerTRAC block calculates the following additional data about the application:

- Fundamental (phase shift) VARs for each phase
- Harmonic VARs as a percent of V-A for each phase
- Total harmonic VARs as a percent of V-A
- Line frequency for each phase
- Temperature alarm for the PowerTRAC block

This data is always displayable on a Hand-held Monitor (version 4.0 or later). By default, it is NOT ordinarily provided to the CPU, and is not assigned reference addresses. However, if your application requires this data regularly, the block's configuration can be changed to enable sending the data each bus scan (see page 3-17). Alternatively, the data can be requested on an as-needed basis using datagrams, as described later in this chapter.

## Displaying Additional Calculated Data with a Hand-held Monitor

The additional calculated data is displayed on a Hand-held Monitor after the calculated and status data. Data is most easily viewed from the Monitor/Control Reference displays.

Pressing F1 (>) displays data in the sequence listed below. When displaying the additional calculated data, the blinking number on line 1 of the HHM indicates the *relative* data word being shown.

Value to Display	Format
Statusinputs	(see previous chapter)
CalculatedData	(see previous chapter)
Commandoutputs	(see previous chapter)
FundamentalVARs	Signed integer, units defined by Hand-held Monitor.
FundamentalPower Factor	Signed fixed point. Format: +/- XX.XXX
Harmonic VARs as % of V-A	Signed integer from 0 to +100.
Linefrequency	Signed integer.
TemperatureAlarm Status	-1, 0, +1
Extended Watt-hour Accumulator	8-digit decimal, occupying two adjacent registers. Uses the same scaling factor configured for regular Watt-hour Accumulator data.

### Format of the HHM Display

When displaying the additional calculated data, the HHM screen format shown below.

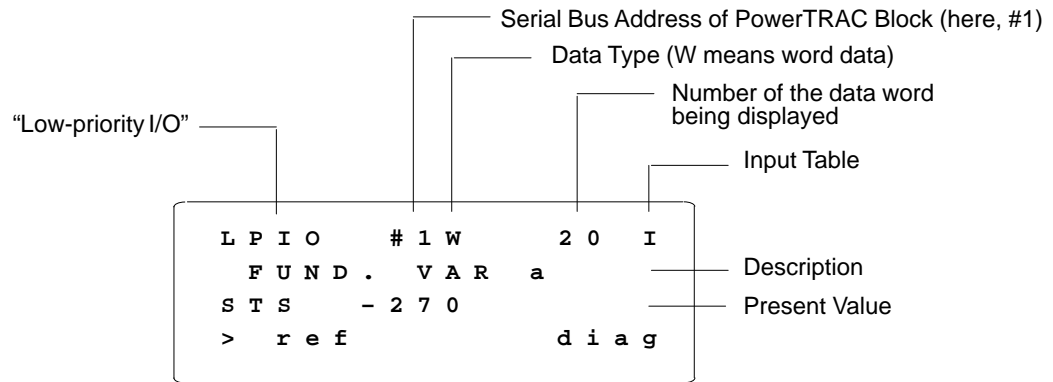

The format shown above appears if the PowerTRAC block is NOT configured to automatically send its additional calculated data each bus scan.

If the block is configured to automatically send its additional calculated data, the top line shows the references assigned to the data item currently being viewed:

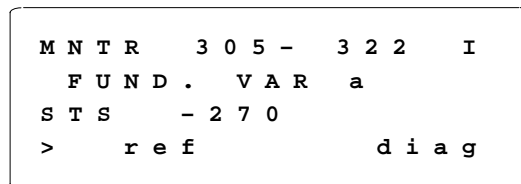

### Data Description

Definitions and example Hand-held Monitor displays are given on the following pages.

## Fundamental VARs

Fundamental VARs represent loss of useful power caused by phase shift. The following example illustrates a 30-degree phase shift.

### Phase Shift Waveforms

<b>Volts:</b>	109.99
<b>Amps:</b>	5.013
<b>Watts:</b>	481.5
<b>VARs:</b>	-270.0
<b>P.F.:</b>	0.873
<b>F VARs:</b>	-270.0
<b>E.P.F.:</b>	0.873
<b>Harmonic VARs as % of V-A:</b>	0

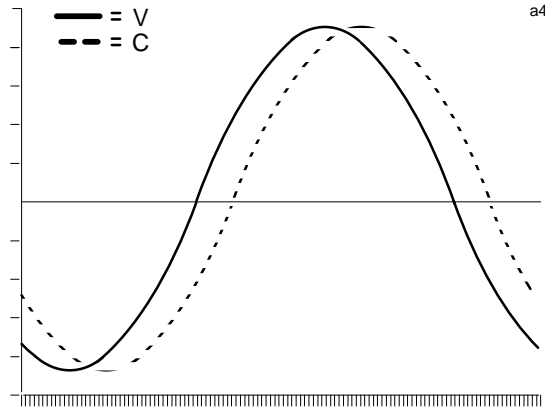

The block automatically calculates Fundamental VARs approximately twice per second. The calculated Fundamental VARs is the numerical integration of V times quadrature current over one cycle (128 samples). The following equation is based on line-to-neutral voltage.

$$VAR_{fun} = \int V \times A (\Theta + 90^\circ)$$

Fundamental VARs can be compensated by adding inductance if current leads voltage, or by adding capacitance if current lags voltage.

### Hand-held Monitor Display

The Hand-held Monitor displays fundamental VARs for each phase.

```

L P I O      # 1 W      2 0  I
  F U N D .   V A R   a
S T S       - 2 7 0
>  r e f                d i a g
    
```

Phase B and phase C fundamental VARs are displayed on the next two screens. The Device Number and word address fields flash at 3-second intervals.

## Fundamental Power Factor, Total

Fundamental power factor indicates the relationship between useful power (Watts and fundamental VARs). The block calculates fundamental power factor approximately twice per second, based upon the relative magnitude of active power and fundamental VARs.

$$PF_{fun} = \cos \theta_{fun} = \frac{W}{(W^2 + VAR_{fun}^2)}$$

The sign of the fundamental power factor indicates the direction of power flow. If the sign is positive, power is being delivered to the load. If the sign is negative, power is being fed back into the system.

### Hand-held Monitor Display

Following the HHM screens for fundamental VARs, the next screen shows fundamental power factor.

```
L P I O      # 1 W      2 3 I
F U N D .   P F   T o t a l
S T S           0 . 8 7 3
>   r e f                   d i a g
```



## Harmonic VARs as % of Volt-Amps

Harmonic VARs are a measurement of reactive power caused by harmonics. Harmonics, which may represent a significant loss of useful power, are commonly caused by equipment such as computers, motor drives, uninterruptable power supplies, and transformers. In addition to degrading power quality, harmonics can cause overheating in mechanical equipment, and other problems.

The following example illustrates a 33% Third Harmonic with no phase shift on the current waveform.

### Current Harmonics Waveforms

<b>Volts:</b>	109.99
<b>Amps:</b>	5.234
<b>Watts:</b>	551.7
<b>VARs:</b>	166.8
<b>P.F.:</b>	0.957
<b>F.VARs:</b>	6.6
<b>F.P.F.:</b>	0.999
<b>Harmonic VARs as % of V-A:</b>	28

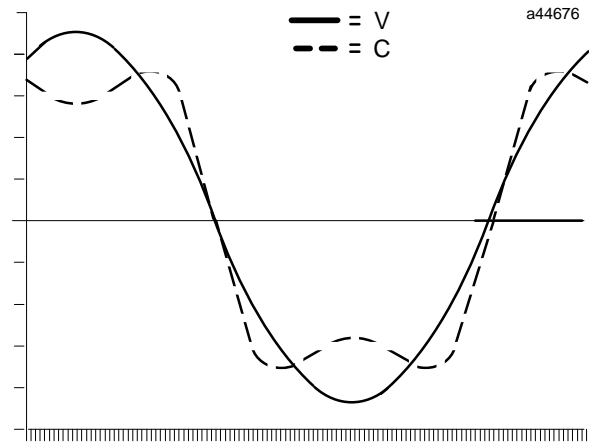

The next example combines a 33% Third Harmonic with a 30 degree phase shift.

### Current Harmonics and Phase Shift Waveforms

<b>Volts:</b>	109.99
<b>Amps:</b>	5.258
<b>Watts:</b>	482.7
<b>VARs:</b>	-320. 5
<b>P.F.:</b>	0.835
<b>F.VARs:</b>	-272. 2
<b>F.P.F.:</b>	0.873
<b>Harmonic VARs as % of V-A:</b>	8

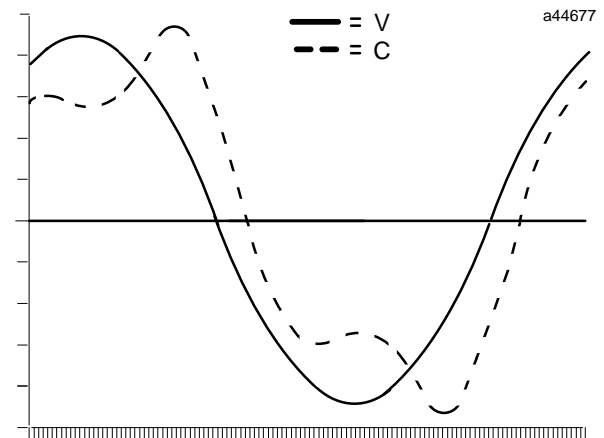

Harmonic VARs on a per-line basis are defined as:

$$VAR_{har} = VAR_{tot} - VAR_{fun}$$

The result shows the percent of useful power being wasted due to harmonics, on each phase. Fourier analysis using the PowerTRAC block's waveform data can be used to pinpoint the cause and correctly compensate for harmonics.

a44679

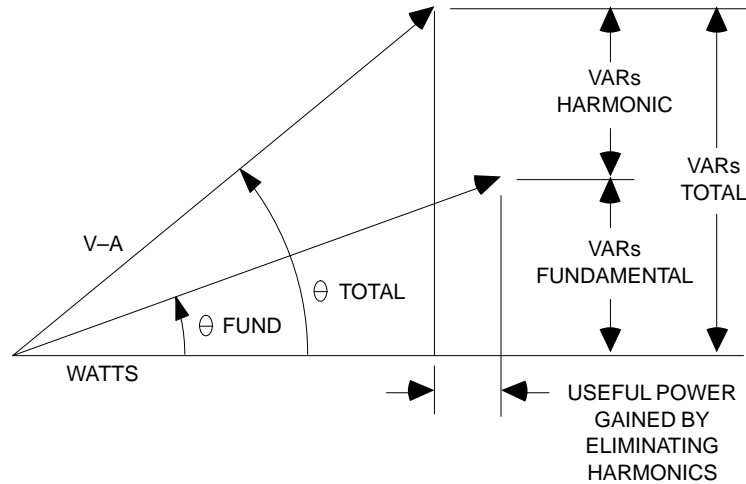

### Hand-held Monitor Display

The Hand-held Monitor displays harmonic VARs for each phase.

```

L P I O      # 1 W      2 4  I
H A R .    V A R a ,    % V - A
S T S          2 8
> r e f          d i a g
    
```

Phase B and phase C harmonic VARs as a % of V-A are displayed on the next two screens.

## Total Harmonic VARs as a Percent of V-A

The block also provides a total harmonic VARS value for all three phases. In the following equation, V is the equivalent line-to-neutral voltage.

$$\text{Harmonic Content} = \frac{\text{VAR}_{\text{har}}}{\text{VA}} \times 100\%$$

The sign of the result indicates the direction of power flow. If the sign is positive, power is being delivered to the load. If the sign is negative, power is being fed back into the system.

### Hand-held Monitor Display

Following the HHM screens for harmonic VARs on each phase, the next screen shows total harmonic VARs.

```
L P I O      # 1 W      2 7  I
H A R .    V A R t ,  % V - A
S T S              2 8
> r e f              d i a g
```

## Line Frequency

The PowerTRAC block monitors the line frequency. Momentary fluctuations in frequency are ignored. Changes in frequency are generally recognized 1 or 2 seconds after stabilizing. Resolution is tenths of a Hertz.

### Hand-held Monitor Display

Following the screens for total harmonic VARs, the HHM displays the line frequency.

```
L P I O      # 1 W      2 8  I
  L I N E    F R E Q U E N C Y
S T S              6 0 . 0
>   r e f              d i a g
```

## Temperature Alarm Status

The host or Hand-held Monitor can query the PowerTRAC block to find out whether its internal temperature is within normal operating limits. The block will respond with one of the following indications:

- 0 if the temperature is between 5C and 55C
- 1 if the temperature is near or below the lower limit
- 1 if the temperature is near or above the upper limit

### Hand-held Monitor Display

After the screen for line frequency, the HHM displays the internal temperature alarm status.

```
L P I O      # 1 W      2 9  I
  I N T .    T E M P    A L A R M
S T S              0
>   r e f              d i a g
```

### Extended Watt-hour Accumulator

The Extended Watt-hour Accumulator contains an eight-digit decimal number with a maximum value of 32,768,999. To make it possible to display the number on a Hand-held Monitor, it has been divided into two portions: the lower three digits and the upper five digits.

The Extended Watt-hour Accumulator uses the same units (Watt-hours, KiloWatt-hours, or MegaWatt-hours) configured for the regular Watt-hour Accumulator. The second line of the HHM display indicates the configured scale factor.

### Hand-held Monitor Display

After the screen internal temperature alarm status, the HHM displays the five upper digits of (indicated by the designation HI) of the Extended Watt-hour Accumulator:

```
L P I O      # 1 W      3 0 I
E X T .     K W - H   ( H I )
S T S              3 2 7 6 7
>   r e f                d i a g
```

Press F1 ( > ) from this screen to display the three lower digits (indicated by the designation LO):

```
L P I O      # 1 W      3 1 I
E X T .     K W - H   ( L O W )
S T S              9 9 9
>   r e f                d i a g
```

**Note:** The “Low” portion of the extended Watt-hour data should always be interpreted as three digits. Leading zeros are not displayed.

## Sending Datagrams to Read Calculated and Status Data

Status and calculated data is always available in the PowerTRAC block's assigned references in the host; the block supplies the data automatically. However, it is also possible to read all status and calculated data directly from the block using Read Device or Read Block I/O datagrams. These datagrams are the ONLY way to read the calculated data (fundamental and harmonic VARs, fundamental Power Factor, Line Frequency, and Temperature Alarm Status) that is not automatically transmitted by the block as part of its regular input data.

Instructions for using a Read Device datagram are given below. The process is similar for a Read Block I/O datagram. If you prefer to use the Read Block I/O datagram, please refer to the *Genius I/O System and Communications Manual* (GEK-90486-1, version D or later) for details. The data offsets described in the Read Device datagram table are also correct for Read Block I/O offsets.

Unlike the procedure for reading Waveform Data or Overcurrent Event Data from a PowerTRAC block (which is explained in chapter 6), reading calculated and status data directly from the PowerTRAC block does NOT require monitoring or setting any status bits.

The block replies to each Read Device or Read Block I/O datagram with a reply datagram of the requested length.

### Datagram Timing

These datagrams are always sent using normal priority. Since only one normal priority datagram can be sent by any device on a bus during a single bus scan, transmission of the data may be delayed if there is other datagram traffic on the bus.

Any of the following errors will cause the PowerTRAC block to ignore the datagrams:

1. incorrect message format
2. invalid data address or length specification.

### Read Device Datagram for Calculated and Status Data

When used to read calculated and status data from a PowerTRAC block, the Read Device datagram has the following content:

function code	20h
subfunction code	1Eh
priority	normal

Byte No.	Description
0	must be 0
1	Data Offset (see table)
2	must be C0 hex
3	must be FF hex
4	must be 0
5	Length of data, in bytes

The data offset specified in byte 1 is the beginning location in the PowerTRAC Block's internal memory where data should be read from. Any beginning location may be selected. The length in bytes is the amount of data to be transferred in one datagram. Each individual data item is 2 bytes in length.

Data Type	To Read Data Beginning Here	Enter this Data Offset in Byte 1 of Read Device Datagram
<p><b>StatusInputs</b></p> <p><b>CalculatedData</b></p> <p>All of this data is automatically sent by PowerTRAC block each bus scan.</p>	<p>StatusInputs</p> <p>Voltage A-B</p> <p>Voltage B-C</p> <p>Voltage C-A</p> <p>Voltage A-N</p> <p>Voltage B-N</p> <p>Voltage C-N</p> <p>Current A</p> <p>Current B</p> <p>Current C</p> <p>Current, aux</p> <p>Watts A</p> <p>Watts B</p> <p>Watts C</p> <p>VARsA</p> <p>VARsB</p> <p>VARsC</p> <p>Power Factor</p> <p>AccumulatedPower</p>	<p>00</p> <p>02</p> <p>04</p> <p>06</p> <p>08</p> <p>0A</p> <p>0C</p> <p>0E</p> <p>10</p> <p>12</p> <p>14</p> <p>16</p> <p>18</p> <p>1A</p> <p>1C</p> <p>1E</p> <p>20</p> <p>22</p> <p>24</p>
<p><b>Additional Data</b></p> <p>The block can be configured to send this extra data automatically*.</p> <p>This data can also be read with Read Device datagram.</p>	<p>Fund. VARsA</p> <p>Fund. VARsB</p> <p>Fund. VARsC</p> <p>Fund. Power Factor</p> <p>Har. VARsA</p> <p>Har. VARsB</p> <p>Har. VARsC</p> <p>Total Har. VARs</p> <p>Line Frequency</p> <p>Temp. Alarm Status</p> <p>Extended Watt-hour Accumulator (high 5 digits)</p> <p>Extended Watt-hour Accumulator (low 3 digits)</p>	<p>26</p> <p>28</p> <p>2A</p> <p>2C</p> <p>2E</p> <p>30</p> <p>32</p> <p>34</p> <p>36</p> <p>38</p> <p>3A</p> <p>3C</p>

\* PowerTRAC blocks with firmware prior to version 3.0 do not have this capability.

## Reply Datagram Sent by the PowerTRAC block

The block replies to each Read Device datagram with a Read Device Reply datagram containing the requested data. When Status or Calculated Data is requested, this datagram has the following content:

function code	20h
subfunction code	1Fh
priority	normal

Byte No.	Description
0	00
1	Data Offset
2	C0 hex
3	FF hex
4	00
5	Length in bytes
6 - n	the requested data

The first five bytes of the reply datagram are the same as the Read Device datagram.

### Note

Some bus controllers, such as the Series 90-70 PLC bus controller, add data to the Read Device Reply datagram before passing it on to the host. Refer to your *Bus Controller User's Manual* for details.



# Chapter 6

## Waveform Data and Overcurrent Data

This chapter explains how the PowerTRAC block stores sampled values representing waveform and overcurrent event data, and how that data can be accessed.

### Input Data Tables

Approximately twice per second, the block samples eight cycles of each voltage and current input. Sampling rate is 16 times the frequency of the monitored voltage. The result is 128 sampled values for each of the seven inputs. The block digitizes these inputs and stores them in the Working Data Table.

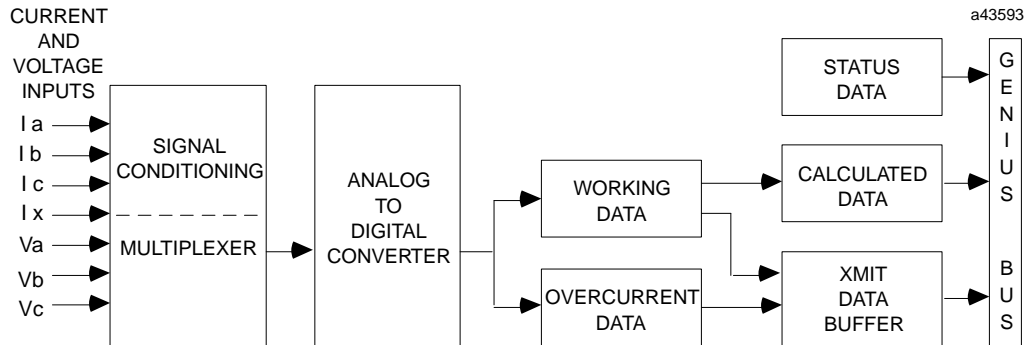

The block uses the values in the Working Data Table as the basis for the voltage, current, and other values which it automatically calculates (see chapter 4 for more information about this calculated data). Input values in the Working Data Table can also be read by a PLC or computer for detailed waveform analysis.

The same input data is also sampled continuously, and stored in the Overcurrent Data Table in a circular queue. If, at any time, one of the current inputs exceeds a configurable overcurrent level for two successive samples, the contents of the Overcurrent Data Table are frozen, trapping the digitized overcurrent waveform. The block automatically informs the controlling PLC or computer that a current overcurrent has occurred by setting the appropriate status bits in the "status inputs" data word. Input values in the Overcurrent Data Table can be read by a PLC or computer for overcurrent analysis.

### Table Format

Both the Working Data Table and the Overcurrent Data Table are 1792 bytes in length, with each voltage and current input occupying 256 bytes. Inputs are stored in this sequence in both tables:

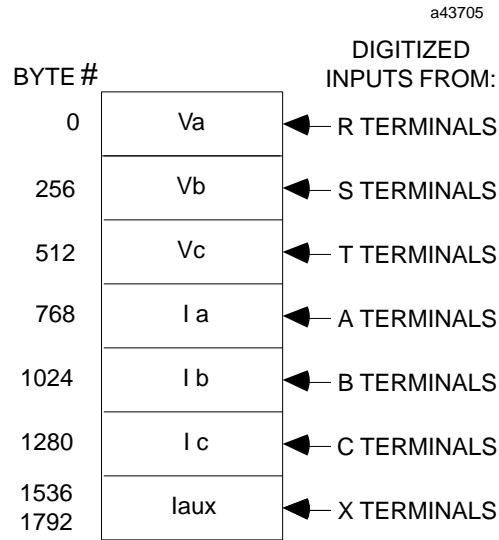

The only table segments that will contain meaningful data are those which have connections at the associated terminals. However, if the PowerTRAC block is configured with two line-to-neutral PTs, the Vb data is meaningful; it synthesized by the block from the Va and Vc data.

## Sampled Waveform Data

The block samples each input at a rate which is 16 times per cycle of the monitored voltage. After each cycle (16 samples), the block delays 1/128 of a cycle before beginning the next 16 samples.

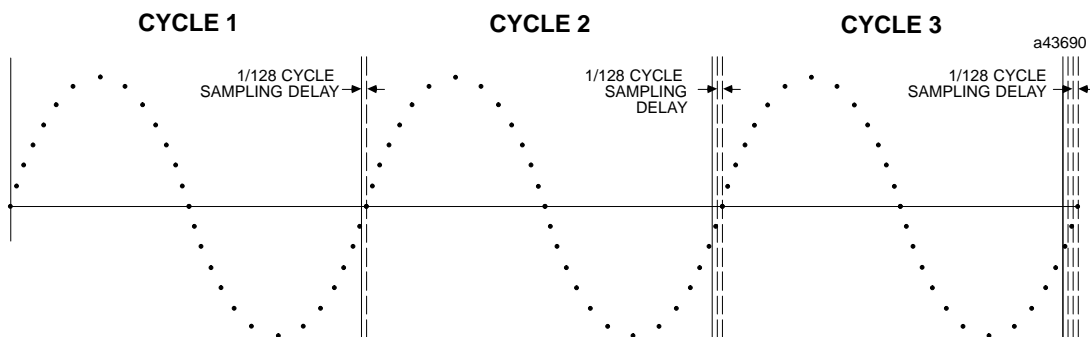

The delay at the end of each cycle (16 samples) allows a single-cycle, 128-point waveform to be synthesized for each input.

To do this, values taken over 8 cycles are interleaved in the Working Data Table to represent a composite waveform which consists of 128 values.

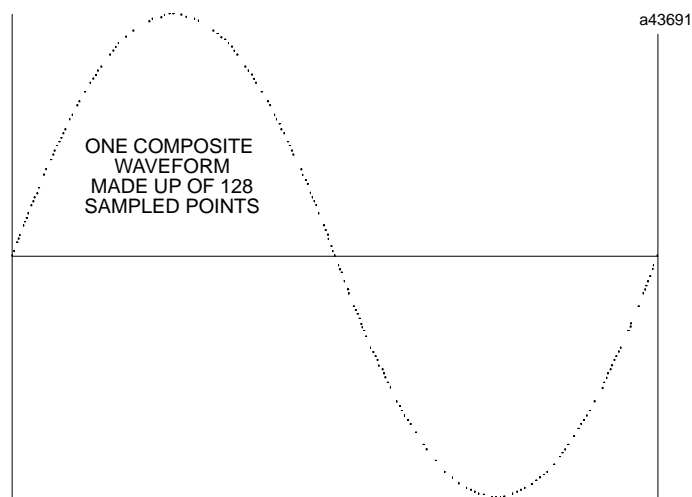

This composite will reveal repetitive high harmonic content distortions in the current waveform.

## Harmonic Analysis of Waveform Values

The values in the Working Data Table can be accessed for harmonic analysis of the input waveforms. Read Device datagram information for obtaining some or all of the data in the Working Data Table is shown in this chapter.

## Overcurrent Data

When the block is configured, two overcurrent levels are selected, one for the three current-phase inputs, the other for the auxiliary current input. If any of the four current inputs exceeds the configured level for 1/8 of the input waveform period, the block stores the values read during the three cycles before the event, plus the five following cycles of data, for all of its inputs, in its internal Overcurrent Data Table. It then freezes the contents of the Overcurrent Data Table. (The block continues sampling inputs and reporting calculated data, but the Overcurrent Data Table remains frozen until the controller reads it).

### Format of the Overcurrent Data Table

In the Overcurrent Data Table, the 128 sampled point values for each input are stored sequentially (rather than interleaved, as they are in the Working Data Table).

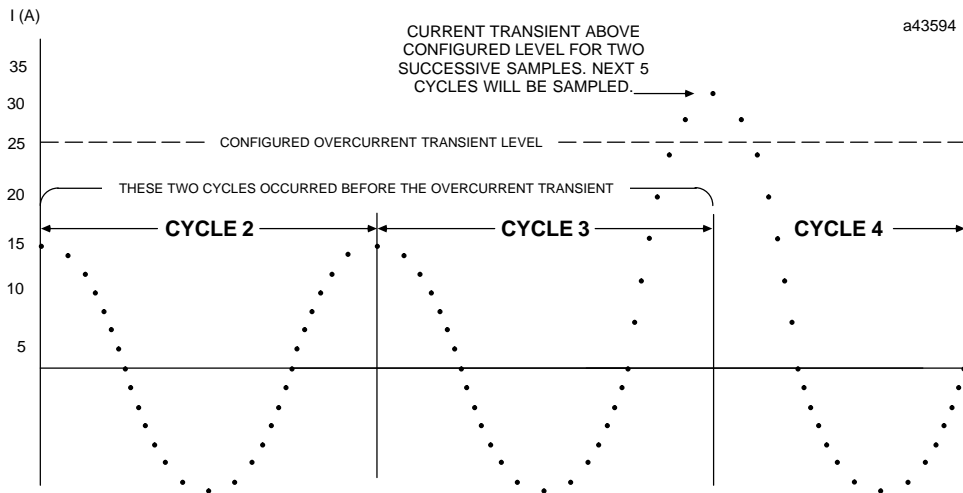

### How the Block Reports an Overcurrent Condition

If an overcurrent transient occurs, the PowerTRAC block reports it by setting the appropriate status bits in the "status inputs" word, which is sent to the host each Genius bus scan.

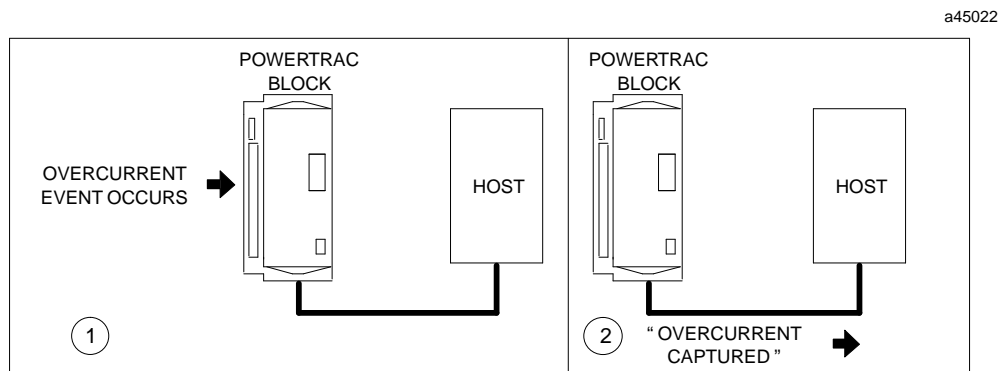

### Block Sets the Status Bits

The first 16 bits of the data that is sent by the block each bus scan are its status inputs. When an overcurrent transient occurs, the block sets its Overcurrent Captured input status bit and the overcurrent channel bit(s) corresponding to the channel(s) on which the overcurrent event occurred.

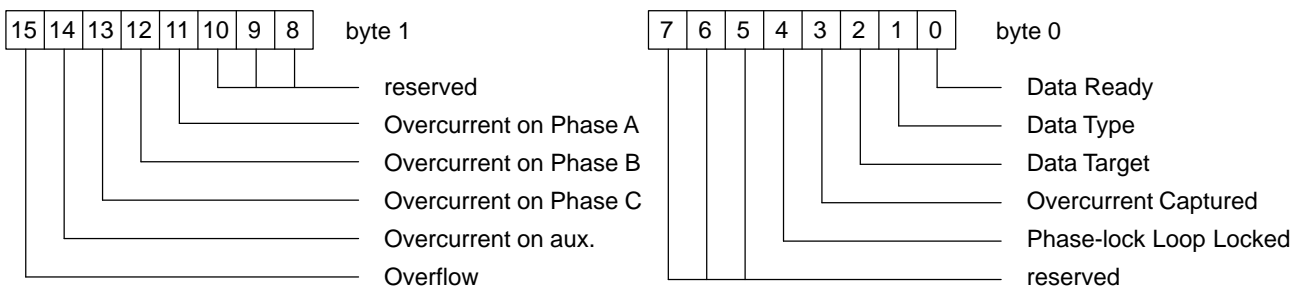

This status information is automatically broadcast by the block the next time it receives the bus token following the occurrence of the overcurrent. The controller receives this status data, and stores it in the block’s assigned input status references. See chapter 4 for more information about status inputs.

For example, if an overcurrent transient occurred on phase A, the block would set the following Status Inputs:

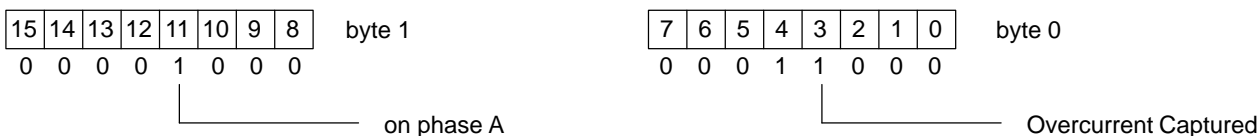

### Monitoring the Status Bits

To read overcurrent data or allow it to be read by one or more monitoring devices, the application program in the controller should monitor the Overcurrent Captured bit. If this bit is set to 1, the application program should request the overcurrent data as described on the next page.

### Clearing the Overcurrent Data

As already explained, the Overcurrent Data Table remains frozen until the controller/data monitoring device initiates the handshaking sequence to read Overcurrent data, described later in this chapter. The frozen Overcurrent Table is copied to the transmit buffer, the Overcurrent flags are cleared, and the Overcurrent Capture function is re-enabled. If an overcurrent event occurs while reading captured data from a previous event, that data remains frozen in the Overcurrent Data table until a subsequent Overcurrent Data read handshaking sequence is initiated.

## Reading Table Data from a PowerTRAC block

There are three basic steps to read either Waveform Data or Overcurrent Event Data from a PowerTRAC block. They are:

1. The application program sets the appropriate “Send Data”, “Data Type”, and “Data Target” output bits in the block’s assigned output references. As explained below, these bits tell the PowerTRAC block what type of data is being requested, and they specify the device that will read the data. The PowerTRAC block responds by making the necessary preparations, and then mirrors these bits in the corresponding “Status Inputs” bits.
2. The application program *in the intended receiving device* (which is usually the controller, but may be another host on the bus) then monitors the block’s status inputs for a “Data Ready” indication.
3. When the “Data Ready” status inputs are detected, the application program (that wants to read the table data) may send datagrams to the block to read the data.

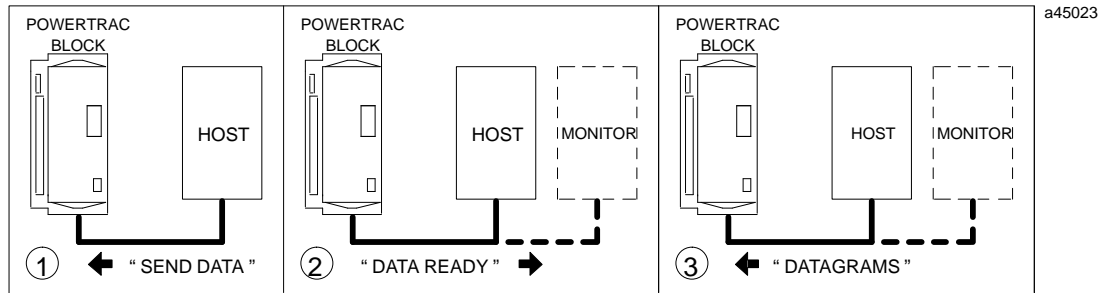

The individual steps in this process are explained in detail below.

### Note

The application program must allow a minimum delay of  $\frac{1}{2}$  second from the end of one complete table reading sequence to the start of the next one.

## Requesting Data Transfer

To request input values from the Overcurrent Data Table or the Working Data Table, the application program in the controller must set up the data transfer by setting or clearing the appropriate output command bits.

These bits must specify the data type to be transmitted, and whether the data should be read by the controller or another device on the bus.

To initiate a request, the Send Data bit must be set to 1. If Overcurrent Table data will be read, the Data Type bit must also be set to 1. Finally, if one or more monitoring devices in addition to or instead of the controller will read the data, the Data Target bit must be set to 1. All other bits are 0. Note that the PowerTRAC block’s “Data Ready” bit must be 0 before initiating a data transfer request sequence.

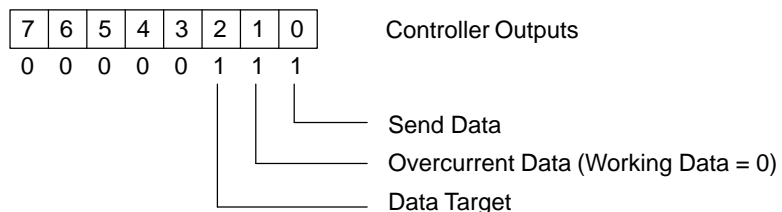

When Working Data is requested, the block copies the current contents of the Working Data Table into the Transmit Data buffer, writing over data already stored there. If Overcurrent Data is requested, and the Overcurrent Data Table is currently frozen because an Overcurrent Event has been captured, the block copies the current content of the table into the buffer. If no new Overcurrent Event Data has been captured then:

- A. if the Transmit Data buffer contains Overcurrent Data that has already been read, that data can be read again.
- B. if the buffer contains Working Data the request is ignored, since there is no available Overcurrent Data to read.

Manipulation of the control output bits is NOT necessary for transmission of normal status and calculated data. If the application does not require working or overcurrent data, all control output bits should be 0.

### Notifying the Controller that Data is Ready

After moving the data, the PowerTRAC block broadcasts the following Input Status bits during its next turn on the bus.

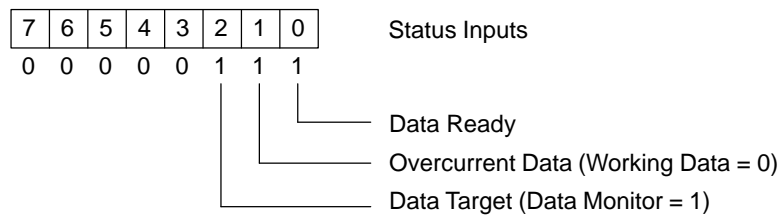

Data Ready indicates that the block has data to transfer. The Data Type and Data Target bits are copies of the corresponding output command bits.

Upon receiving the input status bits with Data Ready set to 1, program logic in the device(s) designated by the Data Target bit should issue the necessary Read Device datagrams to the block. Datagram format is shown later in this chapter.

### Clearing the Data Ready Bit

The block clears the Data Ready bit after it has transmitted a reply to a read request containing the LAST BYTE OF THE TRANSMIT DATA BUFFER.

#### Note

If more than one device is reading data from the block simultaneously, and the last byte of the data buffer is read before all the devices have finished reading the data, the block will clear the Data Ready bit. However, data in the Transmit Data buffer will remain frozen and the PowerTRAC block will continue to service all data requests until the host controller device clears the "Send Data" Control Output.

## Sending Data to Monitoring Devices

If any other device on the bus is to read data from the PowerTRAC block, that device's application program should monitor the block's status input bits. When the device detects that the "Data Ready" and "Data Target" bits are set to 1, it should issue the appropriate Read Device datagrams to the block.

## Completing the Process

When the block has finished responding to the request(s) for table data, the controller and monitoring devices must end the data transmission appropriately.

If the controller alone, and/or one monitor are reading data, the host should monitor the Data Ready input status bit. When the block clears this bit (indicating that the last data byte has been read), the application program should clear the output bits. The exception to this would be if the same data will be sent again to another device. In that case, the "Send Data" output bit should not be cleared until the second data transmission is finished.

If multiple devices will be reading the data, the controller device should take care to ensure that all data monitoring devices have completed all data requests before clearing the "Send Data" Control Output. This may be accomplished by providing a fixed delay or by having monitoring devices report "Read Status" to the host controller via Global Data or status inputs of their own.

If the Data Ready bit stays set for a prolonged period of time after reading the last byte of the data buffer (for example, thirty seconds or more), the application program in the controller can assume that an incomplete data transmission occurred, and that the block has failed to clear the bit. The program can attempt to request the data transmission again.

It is imperative that the "Send Data" Control Output is cleared after the data read transaction has completed.



### Example

The following diagram represents the timing of output command bits from the controller and input status bits from the block, for a system with a host controller and one data monitoring device. In this example, the application program in the controller first requests that the block send Overcurrent Table Data to itself. Following completion of that data transfer, the application program then requests that the same data be read by a monitoring device.

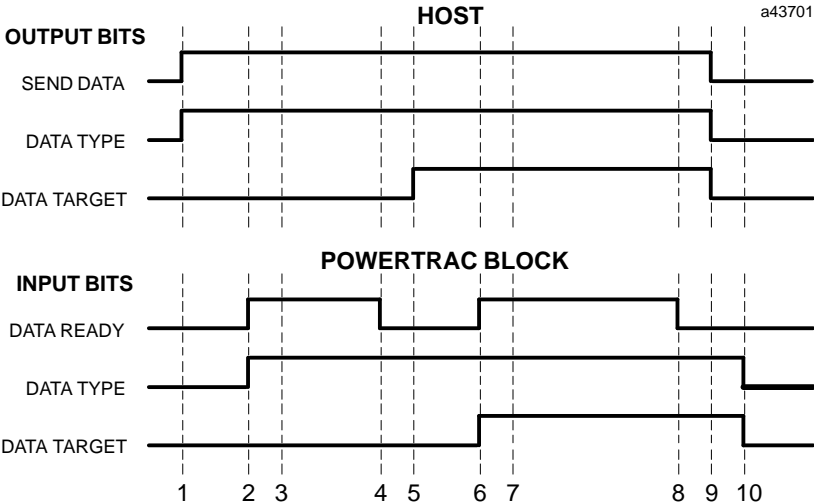

1. The controller sets the Send Data and Data Type output command bits to 1. The Data Target bit is 0, indicating to the data will be received by the controller.
2. Upon receiving these output command bits, the PowerTRAC block prepares the data, then sets Data Ready input status to 1. The Data Type and Data Target input status bits are copies of the corresponding output bits.
3. When the controller detects that the Data Ready input bit is set it begins sending Read Device datagrams to the block.
4. After all the data has been sent, the block clears the Data Ready input status bit.
5. When the controller receives all requested data and detects that the Data Ready bit is cleared, it sets the Data Target output command bit.
6. When the block detects that the Data Target output command bit has changed state, it sets the Data Ready input bit, and copies the Data Target output to the Data Target status input bit.
7. When the monitoring device detects that the block has data ready, and that the Data Target bit is set, it begins sending Read Device datagrams to the block.
8. After all the data has been sent, the block again clears the Data Ready input status bit.
9. When the controller detects that the Data Ready input bit is cleared, it clears all the output command bits.
10. The block then clears the remaining status input bits.

## Sending Datagrams to Read Table Data

After setting up data transfer using the status and control bits, as described previously, the device that wants to read table data from the PowerTRAC block must send it a Read Device datagram. The block sends back a reply datagram with the requested information. Read Device datagram formats are described below.

### Datagram Timing

These Read Device datagrams are always sent using normal priority. Since only one normal priority datagram can be sent by any device on a bus during a single bus scan, transmission of table data may be delayed if there is other datagram traffic on the bus.

Any of the following errors will cause the PowerTRAC block to ignore the datagrams:

1. Incorrect handshake
2. incorrect message format
3. invalid data address or length specification. The entire address/length specified must fall within the range 0 – 1791.

### Read Device Datagram for Table Data

When used to read table data from a PowerTRAC block, the Read Device datagram has the following content:

function code	20h
subfunction code	1Eh
priority	normal

Byte No.	Description
0	must be 0
1	Device Address byte 1
2	Device Address byte 2
3	must be 0
4	must be 0
5	Length in bytes (maximum = 128 per message)

The device address specified in bytes 1 and 2 of the datagram is the byte number location in the transmit buffer that data should be read from. Any beginning location may be selected. The first byte of data is considered to be byte #0. The range of the reply is address through address + (length - 1).

Device Address			For this Input	For Overcurrent Data Only: Input Cycles
Decimal	Hex			
0	0000		Va	1-4
128	0080			5-8
256	0100		Vb	1-4
384	0180			5-8
512	0200		Vc	1-4
640	0280			5-8
768	0300		Ia	1-4
896	0380			5-8
1024	0400		Ib	1-4
1152	0480			5-8
1280	0500		Ic	1-4
1408	0580			5-8
1536	0600		Iaux	1-4
1664	0680			5-8
(Last Byte) 1791	06FF	5-8		

The length in bytes is the amount of data to be transferred in one datagram. The entire transmit buffer contains 1792 bytes of data, arranged in the same format as the table data. Each input occupies 256 bytes of the table, beginning at the byte location shown in the figure. Reading all of the data for one input would require two Read Device Datagrams of length 128. Reading an entire table would require 14 Read Device datagrams of length 128. The last byte (1791) must always be read. This indicates to the PowerTRAC block that the requesting device has read all the data and may serve as an acknowledgement to the host controller device that the last request has been received and processed. The data in the table will remain frozen, and the block will continue to service datagrams until the Send Data Control Output has been cleared.

### Example Datagram:

To read the Overcurrent Table Data for the phase A current input (Ia) only, the requesting device would send at least three Read Device Datagrams.

- Datagram #1: device address = 768 length = 128 bytes
- Datagram #2: device address = 896 length = 128 bytes
- Datagram #3: device address = 1791 length = 1 byte

## Reply Datagram Sent to the Requesting Device

The block replies to each Read Device Datagram with a Read Device Reply datagram containing the requested data. This datagram has the following content:

functioncode	20h
subfunctioncode	1Fh
priority	normal

Byte No.	Description
0	must be 0
1	Device Address byte 1
2	Device Address byte 2
3	must be 0
4	must be 0
5	Length in bytes (maximum = 128 per message)
6 – n	the requested table data

The first five bytes of the reply datagram are the same as the Read Device datagram.

### Note

Some bus controllers, such as the Series 90–70 PLC bus controller, add data to the Read Device Reply datagram before passing it on to the host. Refer to your *Bus Controller User’s Manual* for details.

## Converting the Data to Voltage or Current

The waveform and overcurrent data returned by the PowerTRAC block is unscaled counts; to obtain voltage or current values, the data must be converted as described below.

*To convert counts to volts*

Use this equation:

$$\text{counts} * 0.0739 * \text{PT turns ratio} = \text{Volts}$$

*To convert counts to current*

Use this equation:

$$\text{counts} * 0.0035 * \text{CT turns ratio} = \text{Amperes}$$

# Appendix A

## Special Wiring Instructions

**Follow these instructions only if PTs and CTs are not connected to the PowerTRAC block as shown in chapter 2.**

To operate properly, the block needs at least one voltage input. If the block will be used to monitor current only, you must jumper the power inputs to the R voltage inputs.

### Required PT and CT Connections

For correct calculation of power values, PTs and CTs must be connected to the following input terminals on the PowerTRAC Block.

#### Required Connections

Number of PTs (L-N)	two	A - N		C - N
	one		B - N	

Number of PTs (L-L)	two	B - C		A - B
	one		C - A	

Number of CTs	two	phase A		phase C
	one		phase B	

If PTs and CTs are connected as shown above, turn to chapter 2 "Installation" for wiring instructions.

The block can be used with PTs and CTs which are already connected to power in a different way. The diagrams in this appendix show special wiring for:

- 2 line-to-neutral PTs with 1 or 3 CTs.
- 2 line-to-neutral PTs with 2 CTs.
- 1 line-to-neutral PT with 1 or 3 CTs.
- 3 line-to-line PTs with 1 or 3 CTs.
- 2 line-to-line PTs with 1 or 3 CTs.
- 2 line-to-line PTs with 2 CTs.
- 1 line-to-line PT with 2 CTs.

In each diagram, power phases and block terminals are shown in the following manner:

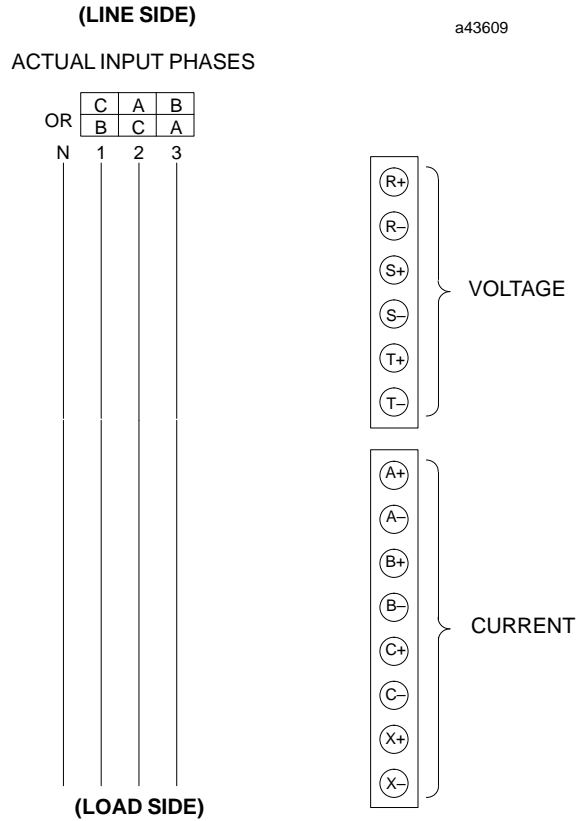

PTs and CTs must be connected to the block as shown in the diagrams.

## Redefining Power Phases

The PowerTRAC block always defines line 1 as “phase A”, line 2 as “phase B”, and line 3 as “phase C”:



Depending on how PTs and CTs are connected to power, the actual phase relationships in the diagrams shown in this appendix may be either of the following:

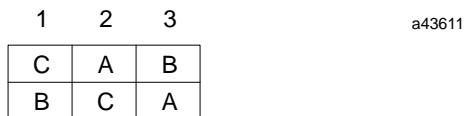

The block will report data correctly, but it will be reported for the EXPECTED phases, with no indication of the changed connections; the block always reports line 1 as phase A, line 2 as phase B, and line 3 as phase C.

For example, suppose that the PTs and CTs were connected like this:



The block would identify (to a Hand-held Monitor and to the CPU) phase C values as phase A, phase A as phase B, and phase B as phase C.

It is important to inform personnel responsible for monitoring data from the block or creating application programs that data is not being reported for the expected phases.

### Note

Mark the changed phases in this manual and in any other documentation that will be used with the block. In addition, post this information where it will be noticed by personnel reading data from the block using a Hand-held Monitor.

## Basic Wiring Instructions

Wiring connections from PTs and CTs may be made with wire sizes up to #10. The terminals will accept bare wires, or spade or ring lugs. If conduit will be used to bring wires or cables for field inputs to the block, its size and installation should be in accordance with local electrical code. For safety, current transformer burdens are permanently connected across the block's current transformer input terminals. No spring-type contacts are used.

Power must be NOT be applied to the PowerTRAC block or input terminals when completing the field wiring.

Connect transformers to the block with the dots as shown. If this is done, power flow in the direction indicated by the arrow in each illustration will provide a + reading for that input.

### Warning

**For personal safety, PT AND CT SECONDARIES MUST BE GROUNDED. Recommended grounding is shown in the diagrams that follow.**

## 2 line-to-neutral PTs with 1 or 3 CTs

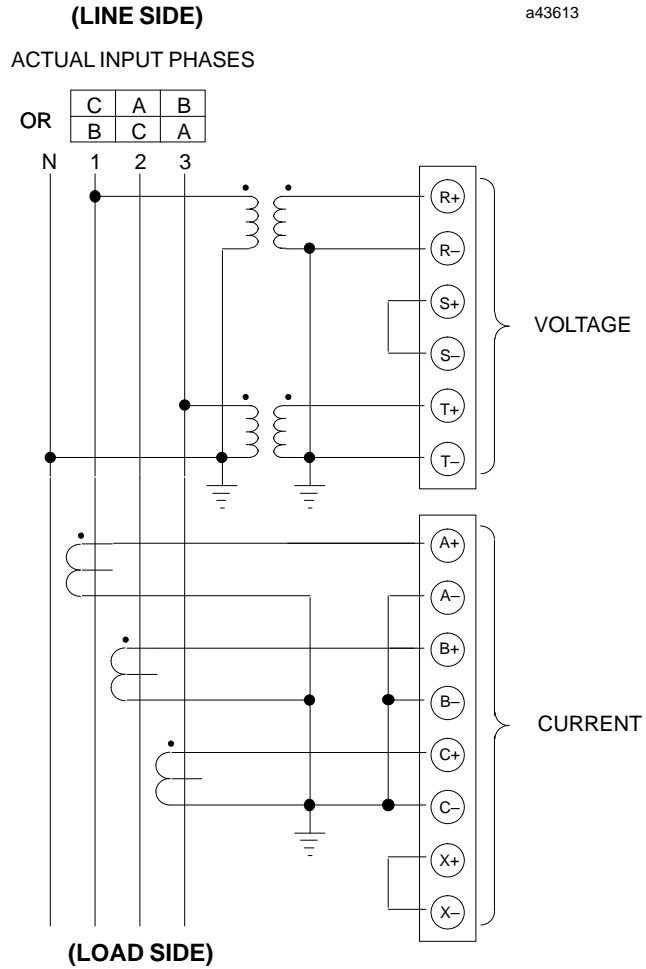

Connect the PTs to the block's R and T terminals. If there is just one CT, connect it to the B terminals. An NCT can be connected to the X terminals as shown in chapter 2.

Data returned by the block for line 1 will be identified as "phase A" current, power, and voltage. Data returned for line 2 will be identified as "phase B". Data returned for line 3 will be identified as "phase C".

The PowerTRAC will synthesize the third voltage (S inputs) from R and T by assuming that  $R + S + T = 0$  at each sample period.

If only one CT is used, total power is calculated to be three times the measured power on phase B.



## 2 line-to-neutral PTs with 2 CTs

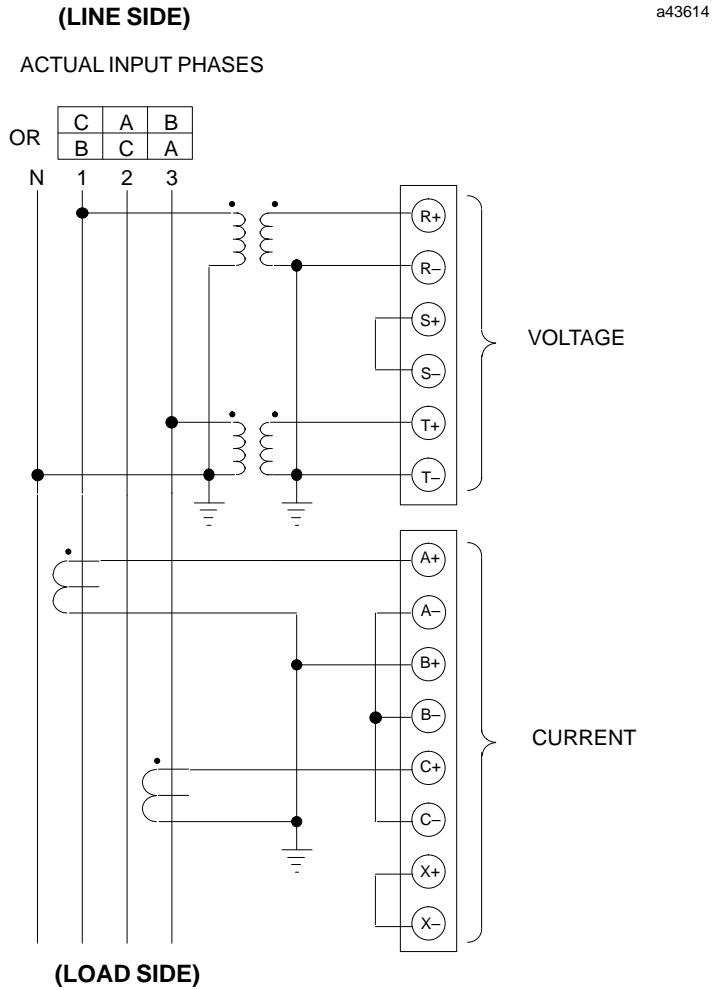

Connect the PTs to the block’s R and T terminals. Connect the CTs to the A and C terminals. An NCT can be connected to the X terminals as shown in chapter 2.

Data returned by the block for line 1 will be identified as “phase A” current, power, and voltage. Data returned for line 2 will be identified as “phase B”. Data returned for line 3 will be identified as “phase C”.

The PowerTRAC will synthesize the third voltage (S inputs) from R and T by assuming that  $R + S + T = 0$  at each sample period.

## 1 line-to-neutral PT with 1 or 3 CTs

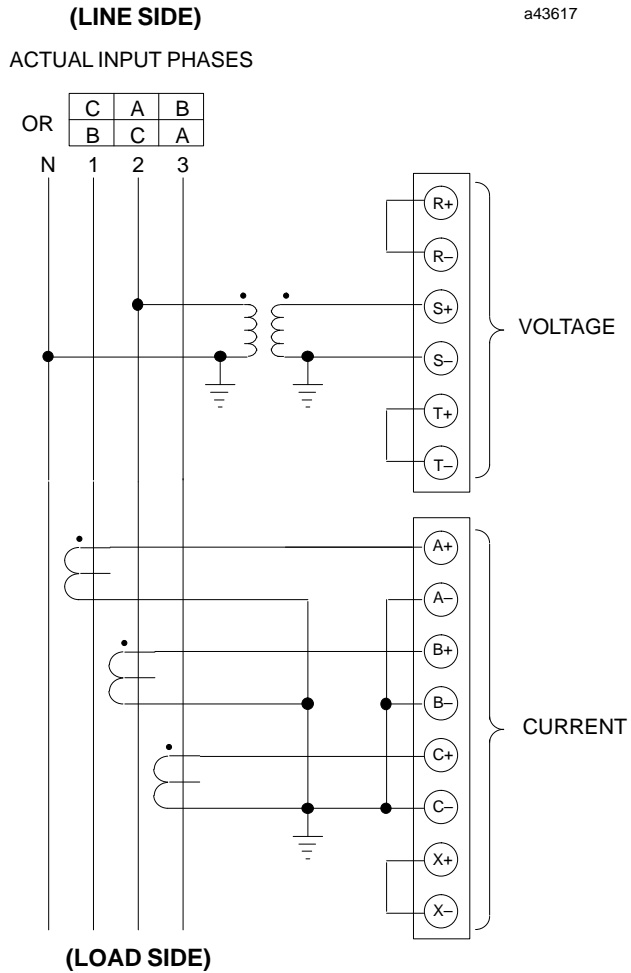

Connect the PTs to the block's R and T terminals. If there is just one CT, it must sense line 2, and it must be connected to input B; otherwise, no power measurement is made.

An NCT can be connected to the X terminals as shown in chapter 2.

Data returned by the block for line 1 will be identified as "phase A" current, power, and voltage. Data returned for line 2 will be identified as "phase B". Data returned for line 3 will be identified as "phase C".

Total power is calculated to be three times the measured power on phase B.

### 3 Line-to-line PTs with 1 or 3 CTs

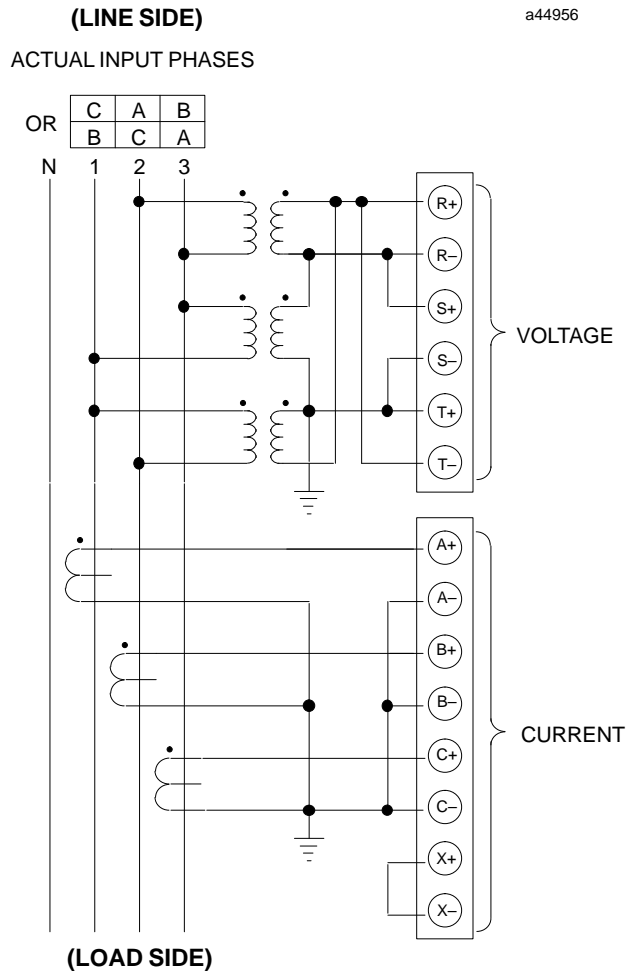

Connect the PTs to the block's R, S, and T terminals. An NCT can be connected to the X terminals as shown in chapter 2.

Data returned by the block for line 1 will be identified as "phase A" current, power, and voltage. Data returned for line 2 will be identified as "phase B". Data returned for line 3 will be identified as "phase C".

## 2 line-to-line PTs with 1 or 3 CTs

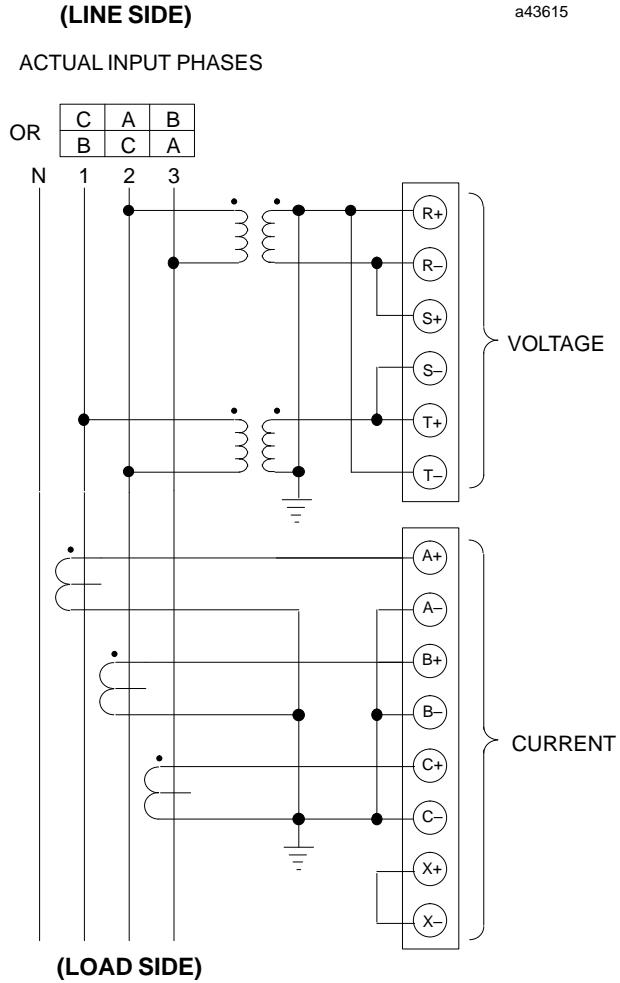

Connect the PTs to the block's R and T terminals. If there is just one CT, connect it to the B terminals. An NCT can be connected to the X terminals as shown in chapter 2.

## 2 line-to-line PTs with 2 CTs

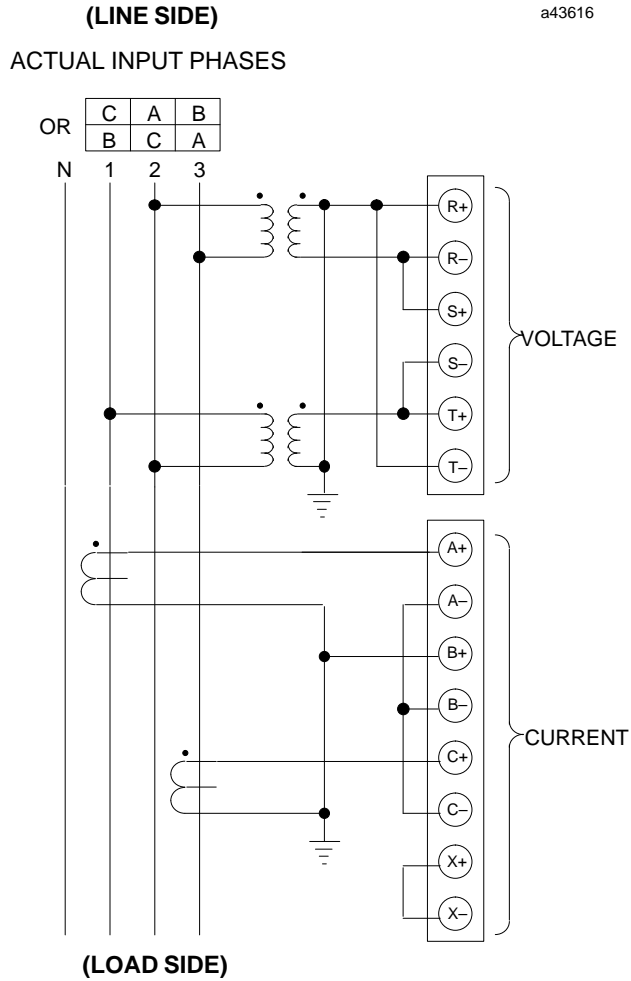

Connect the PTs to the block's R and T terminals. Connect the CTs to the A and C terminals. An NCT can be connected to the X terminals as shown in chapter 2.

Data returned by the block for line 1 will be identified as "phase A" current, power, and voltage. Data returned for line 2 will be identified as "phase B". Data returned for line 3 will be identified as "phase C".

## 1 line-to-line PT with 2 CTs

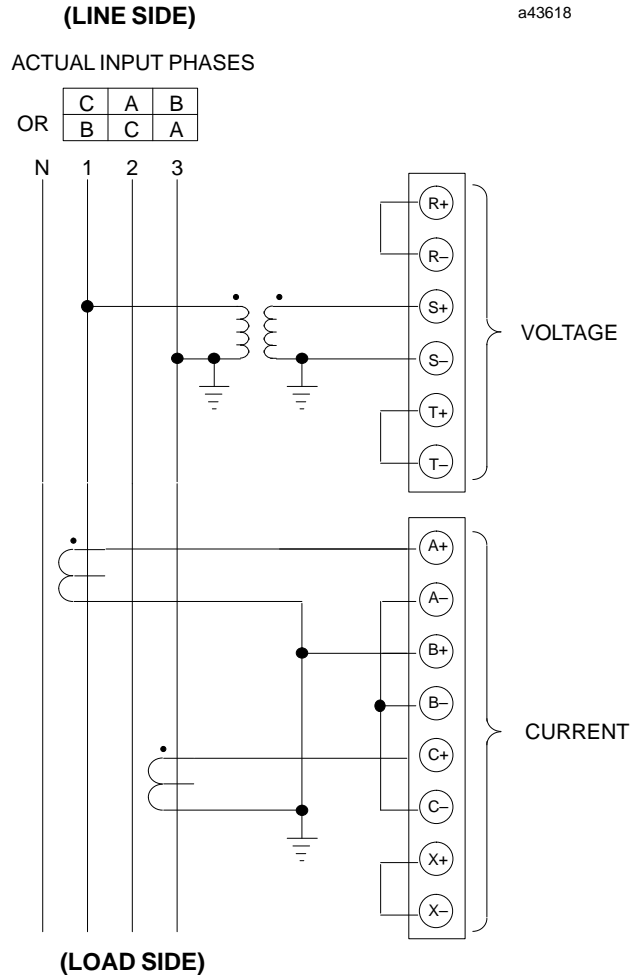

Connect the PT to the block's S terminals. Connect the CTs to the A and C terminals. An NCT can be connected to the X terminals as shown in chapter 2.

Data returned by the block for line 1 will be identified as "phase A" current power, and voltage. Data returned for line 2 will be identified as "phase B". Data returned for line 3 will be identified as "phase C".

Total power as used in the Watt-hour and Power Factor calculations is assumed to be three times the measured power on phase B.

# Appendix B

## Using PTs and CTs With Higher Turns Ratios

---

---

The PowerTRAC block can accept inputs from any PT with a secondary rating of 120V and any CT with a secondary rating of 5A. However, the range of configurable turns ratios for PTs and CTs is:

PT Turns Ratio: 1.0:1 to 2730.0:1 (120V to 327kV primary voltage)  
CT Turns Ratio: 1:1 to 6550:1 (5A to 32750A primary current)

If PTs and/or CTs used with the block have higher turns ratios, refer to the following instructions.

### Configuring Fractional Turns Ratios

If the turns ratio of PTs and/or CTs is too great to be configured directly, it is possible to configure a turns ratio that will produce an easily-understood calculated value. The configured turns ratio may be a fraction (such as 1/10) of the actual turns ratio.

#### Fractional PT Turns Ratio

The block uses the configured PT Turns Ratio to calculate primary line-to-line or line-to-neutral voltage from the secondary input voltage. If a fraction of the actual PT turns ratio is entered, the block will calculate voltage values that represent the same fraction of the primary voltage. For example, configuring 1/10 of the actual PT turns ratio will produce calculated voltages that are 1/10 of the actual primary voltage. As an example, for a PT turns ratio of 5000:1, the value 500 might be configured instead. When configuring the block with a Hand-held Monitor, the value is entered on this screen:

```
PT  TURNS  RATIO
( 1 . 0  T O  2 7 3 0 . 0 )
                    5 0 0 . 0
r n g   c h n g                n x t
```

## Fractional CT Turns Ratio

The block uses the configured CT Turns Ratio to calculate primary line current from the input secondary current. If a fraction of the actual CT turns ratio is entered, the block will calculate current values that represent the same fraction of the primary current. For example, entering 1/10 of the actual turns ratio will produce calculated currents that are 1/10 of the actual line current. As an example, for a CT turns ratio of 8000:1, the value 800 might be entered on this Hand-held Monitor block configuration screen:

```

C T   T U R N S   R A T I O
( 1   T O   6 5 5 0 )

r n g   c h n g           8 0 0
n x t

```

## Fractional Calculated Values

If the block is configured with a fractional PT turns ratio and/or CT turns ratio, the voltage and current calculations based upon those turns ratios will represent the same fraction of the primary voltage or current, as explained above.

These fractional values will be reported to a Hand-held Monitor and to the CPU. For example, if the PT turns ratio has been configured at 1/10 of the actual turns ratio, the calculated voltages will be 1/10 of the actual voltages. If the actual primary line-to-line voltage were really 75000 volts, the Hand-held Monitor would display 1/10 of that value:

## HHM Monitor/Control Reference Display

```

M N T R   1 7 -   3 2   I
V a b   ( K V )
S T S           7 5 . 0 0
>   r e f   f o r c e   d i a g

```

z Voltage A to B  
z displayed value

Similarly, if the CT turns ratio has been configured at 1/10 of the actual CT turns ratio, the calculated current will be 1/10 of the actual line current. If fractional CT turns ratios are programmed, the configured line transient/overcurrent event should be programmed as 1/10 of the desired actual line threshold.



## Fractional Calculated Power Values

The block calculates active and reactive power by multiplying calculated voltage and current values. If a fractional turns ratio has been entered for PTs or CTs but not for both, the calculated power values will represent the same fraction of the actual power values. For example, if the PT turns ratio is configured at 1/10 of the actual PT turns ratio, but the CT turns ratio is configured at the actual turns ratio, the calculated power values will be 1/10 of the actual power values.

However, if BOTH a fractional PT turns ratio and a fractional CT turns ratio are configured, the calculated power values are reduced by a fraction equal to the product of the PT and CT turns ratio fractions. For example, if both the PT turns ratio and the CT turns ratio are configured at 1/10 of the actual turns ratios, the calculated power values represent 1/100 of the actual power values ( $1/10 \times 1/10$ ).

## Recording Changed Turns Ratios

If a PT and/or CT turns ratio is configured as a fraction of the actual turns ratio, it is important to explain to operations and programming personnel how to correctly interpret data received from the PowerTRAC block.

### Note

Mark changed PT and CT turns ratios in this manual and in any other documentation that will be used with the block. Record how to correctly interpret the voltage and/or current and power values reported by the block. In addition, post appropriate instructions for interpreting the block's data where they will be noticed by personnel reading the data with a Hand-held Monitor.

# Appendix C

## Using a PowerTRAC Block for Current Monitoring Only

This appendix describes the necessary wiring and configuration for a PowerTRAC block that will be used to monitor only current where the application does not include any PT. Even though the block will not be used to monitor voltage, an appropriate voltage input must be provided.

### Note

The PowerTRAC block must have input voltage connected to operate properly, and that voltage must be at the same frequency as the current inputs.

## Installation Instructions

When installing the PowerTRAC block to monitor current only, connect the CTs normally, as described in chapter 2 or appendix A.

Connect the voltage source to the block's S terminals. Be sure to observe the correct polarity. Voltage can be obtained from an external source, or from the block itself.

If the block will be operated on 120VAC, the voltage source can be obtained by jumpering the block's power inputs to the S terminals. This is diagrammed below.

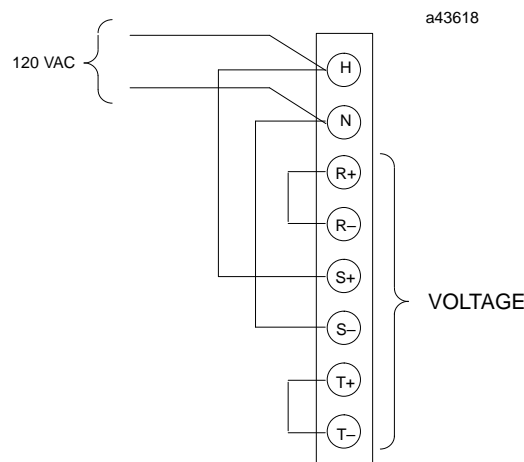

If the block will be operated on some other type of input power, a separate source of 120VAC can be connected to the S terminals instead.

## Configuration

If the block is wired as described above, configure it as follows:

PT Connection	Line-to-neutral
Number of PTs	2
Power Display Units	Not used
PT Turns Ratio	1.0:1

All other features can be configured to reflect the actual installation.

## Monitoring Data

Because actual system voltage is not being monitored, the block's power calculations are not meaningful. For this reason, it is not necessary to configure power display units. The installation and configuration setup described above will cause the block to supply zero or very low values in all its calculations that are based on voltage.

**A**

- AC voltage too low, 4-5
- Accumulated Power, explanation and HHM display, 4-13
- Accuracy of voltage and current measurements, 1-3
- Active Power, 1-7
  - data, in message structure, 4-1
  - explanation and HHM display, 4-10
  - HHM display format, 4-4
- Auxiliary Current
  - explanation and HHM displays, 4-9
  - transient, HHM configuration, 3-12
  - transient, range and default, 3-6

**B**

- Baud rate, 1-10
  - configuring for block, 3-5
  - cycling power after changing, 3-16
  - offline configuration, 3-2
  - selections and default, 3-6
  - stand-alone block, 2-5
- Block
  - description, 1-2
  - dimensions, 1-2
  - failure, LED indication, 2-12
  - features, 1-1
  - operation, description and diagram, 1-5, 6-1
- Block ID configuration, 3-4
- Block power, 1-2
  - applying, 2-12
  - disconnect, 2-4
  - LED indication, 2-12
  - needed for offline configuration, 3-2
  - wiring, 2-6
- BSM Controller, HHM configuration, 3-15
- BSM Present, HHM configuration, 3-15
- BSM Present, selections and default, 3-6
- Burden Per Input, 1-3
- Bus, 1-10
  - connector, 2-4
  - removal, 2-4
  - termination, 2-3
  - wiring, 2-3

**C**

- Calculated Data, 1-7
  - data, in message structure, 4-1
  - displaying with HHM, 4-7
  - for fractional turns ratios, B-2
  - HHM screen sequence, 5-1
  - types not automatically supplied, 5-1
- Catalog number, PowerTRAC block, 1-3
- Cimplicity, 1-12, 1-15
- Command Outputs, 4-14
  - HHM displays, 4-4, 4-15
- Communications failure, LED Indication, 2-12
- Communications handshake, 1-7, 6-8, 6-9, 6-10
- Configuration, 3-1, 3-6
  - data format for datagrams, 3-17
  - defaults, 3-6
  - offline, 3-2
  - stored through loss of power, 3-16
- Configuration Protection
  - HHM configuration, 3-16
  - selections and default, 3-6
- Counts to voltage or current, converting, 6-12
- CPU Memory Usage, 4-2
- CPU Redundancy
  - HHM configuration, 3-16
  - selections and default, 3-6
- CPU References
  - Host Computer, 4-3
  - Series 90 PLC, 4-2
  - Series Five PLC, 4-3
  - Series Six PLC, 4-3
- CT Turns Ratio
  - configurable range, 1-4
  - configuring fractional, B-1
  - HHM configuration, 3-11
  - range and default, 3-6
- CTs, 1-4
  - disconnecting from block, 2-11
  - grounding secondaries, 2-7
  - maximum burden, 1-4
  - not needed if current less than 5A, 1-14
  - number of, configuration steps, 3-8
  - number of, selections and default, 3-6
  - power flow, 2-7
  - primary and secondary ratings, 1-4

- wiring to block, 2-7 , 2-10 , 2-11
- Current, 1-7
  - Line current, explanation and HHM display, 4-9
  - transient, 6-4
  - transient, HHM configuration, 3-12
- Current burden, 1-1
- Current inputs, 1-1
  - auxiliary, HHM display format, 4-4
  - data, in message structure, 4-1
  - HHM display format, 4-4
  - monitoring only, C-1
- Current monitoring only, 1-4

## D

- Data monitoring system, 1-9 , 1-11
- Data read sequence, example, 6-9
- Data Ready bit, clearing, 6-6 , 6-7
- Data Ready output bit, 6-6
- Data Ready status bit, 4-5 , 6-8
- Data scaling, 6-12
- Data Target output bit, 4-14 , 6-6
- Data Target status bit, 4-5
- Data transfer to and from PowerTRAC, 4-1
- Data Type output bit, 4-14 , 6-6
- Data Type status bit, 4-5
- Datagram ignored by block, 6-10
- Datagrams, 1-5
  - returned data format, 5-11
  - timing, 5-10 , 6-10
  - using to read block data, 5-10
- Delta system, 1-1
- Design standards, 1-3
- Device Number, 3-4 , 3-16
- Devices on the Bus, 1-10
- Dimensions, block, 1-2 , 1-3
- Distance from host, maximum, 1-1

## E

- EEPROM failure, LED indication, 2-12

- Electronics Assembly, 1-2
  - installing, 2-12
  - upgrading, 2-12
- Enclosure, using to protect block, 2-1
- Extended Watt-hour Accumulator, explanation and HHM display, 5-9

## G

- Grounding, 2-7
  - for offline configuration, 3-2
  - PowerTRAC, 2-6
  - PT and CT secondaries, 2-7 , A-3

## H

- Hand-held Monitor, 1-10 , 5-2
  - compatibility, 1-12
  - connect to block, 3-3
  - data displays, 4-4
  - keyswitch position, 3-3
  - PowerTRAC connector, 1-2
  - status inputs displays, 4-6
  - using to configure block, 3-1
- Handshake, communications, 1-7 , 1-8 , 4-1 , 4-14 , 6-9 , 6-10
- Harmonic analysis, 1-5 , 1-8 , 6-3
- Harmonic VARs, 1-8
  - as % of Volt-Amps, 5-5
  - explanation and HHM display, 5-5
  - HHM format, 5-1
  - Total, explanation and HHM display, 5-7
- Harmonics waveforms, 5-5
- Host computer, reference usage, 4-3
- Host computer, using, 1-10
- Host CPU type, setting up HHM, 3-3
- Humidity tolerance, 1-3

## I

- Input data format, 6-2
- Input data tables, 6-1
- Input sampling, simultaneous, 1-6
- Installation Steps, 2-1

## L

- LEDs, 1-2 , 2-12
  - indications at powerup, 2-12

- operation on stand-alone block, 2-5
- Line frequency
  - calculated, 1-8
  - configuring automatic reporting of, 3-14
- Line frequency, explanation and HHM display, 5-8
- Load Monitoring, 1-14
- Load scheduling, 1-15
- Load shedding, 1-13 , 1-15
- Locations for block, 2-1
- Logicmaster software, versions required, 1-12

## M

- Module status LEDs, 2-12
- Monitoring current only, 2-7
- Monitoring devices, sending data to, 6-8
- Multiplexed input data, Series Six PLC, 4-3

## N

- NCT Turns Ratio, HHM configuration, 3-11
- NCT Turns Ratio, range and default, 3-6

## O

- Operating temperature range, 1-3
- Outputs from host, explanation, 4-14
- Outputs, setting to 0, 4-1
- Overcurrent
  - configurable threshold, 1-1
  - data, 1-7
  - Data Table, 6-4 , 6-6
  - data, reading, 5-10
  - location status bits, 6-5
  - Overcurrent Captured status bit, 6-5
  - status bit, 4-5
- Overcurrent Captured status bit, 4-5 , 6-4
- Overcurrent Data, explanation and diagram, 6-4

- Overcurrent Data Table, 1-5
  - clearing when frozen, 6-5
  - organization, 6-2
  - reading, 4-14
  - reading, example, 6-9
- Overflow, caused by incorrect configuration, 3-9
- Overload capability, 1-4

## P

- PCIM/QBIM versions, 1-12
- Phase relationships of calculated data, 1-6
- Phase shift, 5-3 , 5-5
- Phase-lock Loop status bit, 4-5 , 6-5
- PLC, using with PowerTRAC blocks, 1-10
- PLC, versions required, 1-12
- Power Display Units
  - HHM configuration steps, 3-9
  - selections and default, 3-6
- Power Factor, 1-7
  - configuring sign for, 3-13
  - data, in message structure, 4-1
  - explanation and HHM display, 4-12
  - Fundamental, explanation and HHM display, 5-4
  - HHM display format, 4-4
- Power flow, monitoring, 1-13
- Power Phases, redefining, A-2
- Power supply, block, 1-1 , 1-2
- Power Units, range and resolution, 3-9
- PowerTRAC block, configuration data, 3-17
- PowerTRAC Block Specifications, 1-3
- PT and CT connections, required, A-1
- PT Connection, HHM configuration steps, 3-7
- PT connection, selections and default, 3-6
- PT Turns Ratio, 1-3
  - configuring fractional, B-1
  - HHM configuration, 3-10
  - range and default, 3-6
  - reconfiguring, 2-12
- PTs, 1-4
  - 120-volt lines without, 1-14
  - grounding secondaries, 2-7

- line-to-line, wiring to block, 2-9 , 2-10
- number of, configuration steps, 3-8
- number of, selections and default, 3-6
- operating without, 1-4 , C-1
- power flow, 2-7
- primary and secondary ratings, 1-4
- wiring to block, 2-7 , 2-8

## Q

- QBIM, compatibility, 1-12

## R

- Reactive Power, 1-7
  - data, in message structure, 4-1
  - explanation and HHM display, 4-11
  - HHM display format, 4-4
- Read Block I/O datagram, 5-10
- Read Device datagram, 5-10 , 6-10
- Read Device Reply Datagram, 5-12 , 6-12
- Reading table data, sending datagrams, 6-10
- References
  - configuration, 3-4
  - required, 4-2
  - selection, 4-2
  - stand-alone block, 2-5
- Requesting data transfer via Output Command bits, 6-6

## S

- Sampling, simultaneous, 1-6
- Secondary ratings, 1-4
- Send Data output bit, 4-14
- Send Data output bit, clearing, 6-8
- Sending Datagrams to Read Table Data, 6-10
- Series 90-70 PLC
  - compatibility, 1-12
  - reference usage, 4-2
- Series 90-70 PLC, reference usage, 4-2
- Series Five PLC
  - compatibility, 1-12

- reference usage, 4-3
- Series Six PLC, reference usage, 4-3
- Series Six PLC, compatibility, 1-12
- Shorting bars, 1-4
- Single-phase Monitoring, 1-14
- Specifications, 1-3
- Stand-alone Block, 1-9
  - installation, 2-5
  - operation, 1-1
- Standards, design, 1-3
- Status Data, 1-5 , 1-7
  - HHM formats, 4-6
  - location in message structure, 4-1
- Status Inputs, 4-5
  - Data Ready, 4-5
  - Data Target, 4-5
  - Data Type, 4-5
  - Overcurrent, 4-5
  - Overcurrent Captured, 4-5
  - Overflow, 4-5
  - Phase-loop Locked, 4-5
- Storage temperature range, 1-3
- Substation Monitoring, 1-15
- Switch gear, using with PowerTRAC, 1-15
- System Monitoring, 1-13
- System, PLC and PowerTRAC, 1-10

## T

- Temperature Alarm
  - calculated, 1-8
  - configuring automatic reporting of, 3-14
- Temperature Alarm Status, explanation and HHM display, 5-8
- Temperature ranges, 1-3
- Terminal Assembly, 1-2
  - installation, 2-2
  - removal, 2-2 , 2-4
- Termination, 2-3
  - block, for offline configuration, 3-2
  - needed for stand-alone block, 2-5
- Transmit buffer, 1-5
  - reading last byte, 6-6
- Troubleshooting: LEDs, 2-12

Typical Applications, 1-13

## U

Update rate, 1-3 , 1-5

## V

VARs

configuring automatic reporting of, 3-14

configuring sign for, 3-13

Fundamental, explanation and HHM display, 5-3

Fundamental, HHM format, 5-1

Harmonic, explanation and HHM display, 5-5

Harmonic, HHM format, 5-1

Vibration tolerance, 1-3

Voltage, 1-7

HHM display format, 4-4

L-L, explanation and HHM displays, 4-7

L-N, explanation and HHM displays, 4-8

synthesized with 1 or 2 PTs connected, 2-8

Voltage inputs, 1-1

data, in message structure, 4-1

## W

Watt-hours, 1-7

accumulator, reset to 0, 3-16

data, in message structure, 4-1

explanation and HHM display, 4-13

HHM display format, 4-4

Waveform Data, 1-7 , 1-8

reading, 5-10

sampling technique and diagrams, 6-3

transmitting, 3-1

Wiring instructions

basic, 2-7 , A-3

special, A-1

Wiring PTs and CTs, 2-7

Working Data Table, 1-5 , 6-6

organization, 6-2

reading, 4-14

Wye system, 1-1