



GE Fanuc Automation

Programmable Control Products

*Series 90[™] -30
Enhanced Genius[®] Communications Module*

User's Manual

GFK0695A

July 1997

Warnings, Cautions, and Notes as Used in this Publication

Warning

Warning notices are used in this publication to emphasize that hazardous voltages, currents, temperatures, or other conditions that could cause personal injury exist in this equipment or may be associated with its use.

In situations where inattention could cause either personal injury or damage to equipment, a Warning notice is used.

Caution

Caution notices are used where equipment might be damaged if care is not taken.

Note

Notes merely call attention to information that is especially significant to understanding and operating the equipment.

This document is based on information available at the time of its publication. While efforts have been made to be accurate, the information contained herein does not purport to cover all details or variations in hardware or software, nor to provide for every possible contingency in connection with installation, operation, or maintenance. Features may be described herein which are not present in all hardware and software systems. GE Fanuc Automation assumes no obligation of notice to holders of this document with respect to changes subsequently made.

GE Fanuc Automation makes no representation or warranty, expressed, implied, or statutory with respect to, and assumes no responsibility for the accuracy, completeness, sufficiency, or usefulness of the information contained herein. No warranties of merchantability or fitness for purpose shall apply.

The following are trademarks of GE Fanuc Automation North America, Inc.

Alarm Master	Field Control	Modelmaster	Series One
CIMPLICITY	GEnet	PowerMotion	Series Six
CIMPLICITY Control	Genius	ProLoop	Series Three
CIMPLICITY PowerTRAC	Genius PowerTRAC	PROMACRO	VuMaster
CIMPLICITY 90-ADS	Helpmate	Series Five	Workmaster
CIMSTAR	Logicmaster	Series 90	

This book describes the features, installation, and operation of the Series 90™ -30 Enhanced Genius Communications Module.

Contents of this Manual

This book contains the following chapters:

Chapter 1. Introduction: describes the capabilities and appearance of the Enhanced Genius Communications Module and lists its specifications.

Chapter 2. Hardware Installations: explains how to install or remove an Enhanced Genius Communications Module and how to remove and replace the module's Terminal Assembly. This chapter also explains how to choose and install the bus cable, and how to install an optional connector for a Genius Hand-held Monitor.

Chapter 3. Operation and Timing: explains how the GCM+ sends, receives, and allocates Global Data. It also describes how other devices on the bus handle GCM+ Global Data and explains how to estimate the CPU sweep time and bus scan time contribution of the GCM+.

Chapter 4. Configuration: describes the module's selectable features and summarizes configuration steps for a Hand-held Programmer.

Chapter 5. Diagnostics: describes the diagnostics features of the Enhanced Genius Communications Module:

Appendix A. Characteristics of the Genius Bus.

Appendix B. Comparison of the GCM+ and GCM.

Changes in This Version of the Manual

This manual has been extensively revised and reorganized. Major changes include:

1. Information on bus cable types has been updated and expanded.
2. Information on bus installation has been expanded.
3. Information specific to the Logicmaster 90 programming and configuration software has been removed.
4. The module configuration chapter has been restructured to include Hand-held Programmer configuration steps with parameter definitions.
5. An appendix detailing the electrical characteristics of the bus has been added.

Related Publications

For more information, refer to the following publications:

Series 90-30 Installation and Operation Manual (GFK-0356): This manual is the primary reference for information about the Series 90-30 PLC.

Hand-held Programmer User's Manual (GFK-0402): This book describes the Hand-held Programmer displays, and explains operator procedures for module configuration, programming, and data monitoring.

Logicmaster 90-30 Software User's Manual: This manual explains how to use the Logicmaster 90-30 software for programming and configuring a Series 90-30 PLC.

Genius I/O System User's Manual (GEK-90486-1): Reference manual for system designers, programmers, and others involved in integrating Genius I/O products in a PLC or host computer environment. This book provides a system overview, and describes the types of systems that can be created using Genius products. Datagrams, Global Data, and data formats are defined.

We Welcome Your Comments and Suggestions

At GE Fanuc automation, we strive to produce quality technical documentation. After you have used this manual, please take a few moments to complete and return the Reader's Comment Card located on the next page.

Jeanne Grimsby
Senior Technical Writer

Chapter 1	Introduction	1-1
	Overview	1-1
	Module Description	1-2
	LEDs	1-2
	Module Specifications	1-3
	Compatibility	1-3
	Global Data for the GCM+	1-4
	Diagnostics Provided by the GCM+	1-4
	Some Special Applications	1-5
	Data Monitoring by a Computer	1-5
	Monitoring Inputs from I/O Blocks	1-6
	Communications Among Bus Devices	1-7
	Using Global Data Communications to Emulate Remote I/O	1-8
 Chapter 2	 Hardware Installation	 2-1
	Module Installation and Removal	2-1
	Module Installation	2-1
	Module Removal	2-2
	Terminal Assembly Removal and Installation	2-3
	Bus Cable Selection	2-5
	Using Other Cable Types	2-6
	Bus Length	2-6
	Baud Rate Selection	2-6
	Bus Installation	2-7
	Wiring Guidelines	2-9
	Lightning Transient Suppression	2-9
	Installing a Hand-held Monitor Connector	2-10
 Chapter 3	 Operation & Timing	 3-1
	How the GCM+ Handles Global Data	3-1
	GCM+ Receives Global Data	3-2
	GCM+ Sends Global Data	3-3
	Global Data Without an Application Program	3-3
	How Other Devices Handle GCM+ Global Data	3-4
	Timing Considerations	3-5
	Bus Scan Time for Global Data	3-6
	Estimating Data Response Time	3-7
 Chapter 4	 Configuration	 4-1
	Initial Configuration	4-1
	Global Data Transmissions during Reconfiguration	4-1

Contents

Starting Hand-held Programmer Configuration	4-2
Configurable Features of the GCM+	4-4
Status	4-4
Bus Address (Device Number)	4-5
Baud Rate	4-5
Series Six Reference	4-6
Data Default	4-6
Report Faults	4-7
Drop ID	4-7
Global Data References, Lengths, & Offsets	4-8
Configuration Example 1	4-10
Configuration Example 2	4-12
Configuration Example 3	4-14
Configuration Example 4	4-16
Configuration Example 5	4-19
Chapter 5 Diagnostics	5-1
Status Bits	5-1
Fault Reports	5-2
Appendix A Characteristics of the Genius Bus	A-1
Electrical Interface	A-2
Serial Bus Waveforms	A-4
Effect of Long Cables, Repeaters, or Unspecified Cable Types on Maximum Length Bus	A-5
Serial Data Format	A-6
Bus Access	A-7
Bus Errors Caused by Noise	A-7
Appendix B Comparison of the GCM+ and the GCM	B-1

Chapter 1

Introduction

Overview

The Series 90™ -30 Enhanced Genius Communications Module (IC693CMM302) is an intelligent module that provides automatic “global data” communications between a Series 90-30 PLC and up to 31 other devices on a Genius bus.

The Enhanced Genius Communications Module (GCM+) can be located in any standard Series 90-30 CPU rack, I/O rack, or remote I/O rack.

Two or more GCM+ modules can be installed in a Series 90-30 PLC. Each GCM+ has its own Genius bus, which can serve up to 31 additional devices. That means a Series 90-30 PLC equipped with two GCM+ modules can exchange global data with as many as 62 other Genius devices automatically.

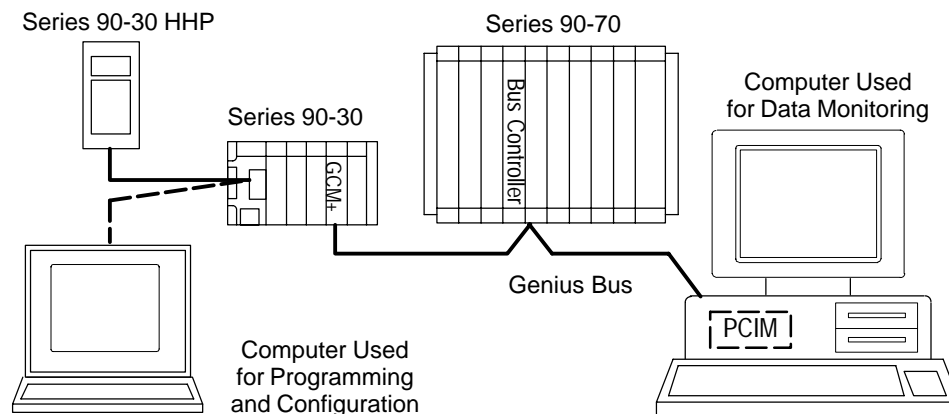

The illustration above represents a Series 90-30 PLC with an Enhanced Genius Communications Module that can exchange Global Data with a Series 90-70 PLC and a computer equipped with a PCIM card. The diagram also shows a Hand-held Programmer and a computer, both of which can be used to configure the Series 90-30 PLC and GCM+. The GCM+ can monitor input data from I/O devices; however, it cannot control I/O devices.

Module Description

The GCM+ is a standard Series 90-30 PLC module. It plugs easily into the PLC's backplate. The latch on the bottom of the module secures it in position.

The module's Terminal Assembly, with its protective hinged cover, is removable. Bus connections are made to the Terminal Assembly and routed out through the bottom. The Terminal Assembly can be removed without breaking the bus and disrupting Genius communications if appropriately installed as described in chapter 2.

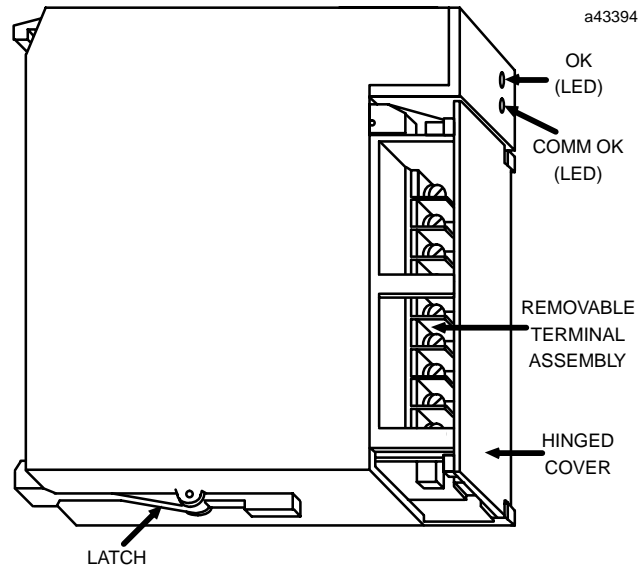

There are no DIP switches or jumpers to set on the module. Its configuration is completed using the Hand-held Programmer or system programming software. A GCM+ can not be configured with a Genius Hand-held Monitor.

LEDs

LEDs on the front of the GCM+ module indicate its operating status, and the status of communications between the module and the Series 90-30 PLC.

- OK** indicates that the GCM+ has passed its powerup test and is operating.
- COMM** indicates that the GCM+ is configured and is transmitting or receiving global data.

If either OK or COMM is off or blinking, look for the following causes:

OK LED	COMM LED	Indicates:
ON	ON	Normal operation
ON	Blinking	Intermittent bus operation
Synchronous blinking	Synchronous blinking	Genius Bus Address conflict
ON	OFF	Module not configured, or no communications
OFF	OFF	No power or fatal powerup error

Module Specifications

Ordering information	IC693CMM302
Module type	Series 90-30 PLC module, providing Genius Global Data communications with up to 31 other devices.
Quantity per PLC	Up to 2
Current consumption	<300mA at +5VDC
Global data length per GCM+	
Transmitted:	Up to 128 bytes.
Received:	Up to 128 bytes each from up to 31 other devices.
Series 90-30 PLC, memory types for global data	%G, %I, %Q, %AI, %AQ, %R
LEDs	OK, COMM
Software diagnostics	Status bits, Fault Reporting to Series 90-70 PLC
Environmental:	
Operating temperature	0°C to +60°C (+32°F to +140°F)
Storage temperature	-25 °C to +70°C (- 13°F to +158°F)
Humidity	5% to 95% (non-condensing)
Vibration and shock	0.2 inch displacement 5Hz to 10Hz 1 G 10Hz to 200Hz 5 G 10Ms duration

Compatibility

Specific equipment or software versions required for compatibility with the GCM+ module are listed below.

- Series 90-30 PLC** **CPU:** The GCM+ module can be used with CPU models: IC693CPU311K, 321K, 331L or later. Other CPU models can be any version. The CPU firmware must be rel. 3.5 or later.
LogiMaster 90-30 software: rel. 3.5 (IC641SWP301L, 304J, 306F, 307F) or later is required.
Genius Communications Module: The GCM+ cannot be installed in a Series 90-30 PLC that also has a Genius Communications Module (IC693CMM301). However, that module can be located in another PLC on the bus, and it may exchange global data with a GCM+. Appendix B compares the features of the GCM+ with those of the GCM.
- Series 90-70 PLC** **Bus Controller:** v. 3.0 (IC697BEM731D) or later is required. If the Series 90-70 PLC will receive fault reports from the GCM+, the bus controller must be v. 4.0 (IC697BEM731F) or later. If **LogiMaster 90-70 Software** is used, it must be version 4.0 or later.
- Series Six PLC** **Bus Controller:** To exchange global data with a GCM+, the Series Six Bus Controller must be catalog number IC660CBB902F/903F (firmware version 1.5), or later.
- Genius Hand-held Monitor** A Genius Hand-held Monitor can be used to display: the GCM+ Bus Address, its software version, and the Series Six register address configured for global data. HHM version IC660HHM501H (rev. 4.5) or later is required. There is no Hand-held Monitor connector on the GCM+ module, but a Hand-held Monitor may communicate with the GCM+ while connected to any other device on the bus. Optionally, an additional HHM mating connector can be installed on the bus near the GCM+.
- Genius I/O Blocks** Genius I/O blocks may be present on the same bus. However, the GCM+ is *not* compatible with older “phase” A blocks; they should not be installed on the same bus.

Global Data for the GCM+

Global data is data that is transmitted automatically and repeatedly, allowing the formation of a shared database. The GCM+ can exchange global data with any other PLC or host computer in the bus.

Each bus scan, a GCM+ module can send up to 128 bytes of global data from exactly one of the following: %I, %Q, %G, %AI, %AQ, or %R memory in the Series 90-30 PLC. Because the global data is broadcast, the same data is available to all other global data devices on the bus.

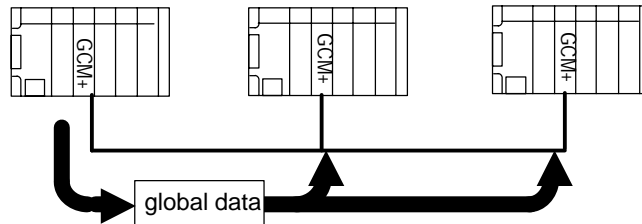

Conversely, each bus scan the GCM+ module can pass to the CPU up to 128 bytes of global data each from up to 31 other devices on the bus. If the Series 90-30 PLC does not need certain global data that is being sent, the GCM+ can easily be configured to ignore all or part of any global data message.

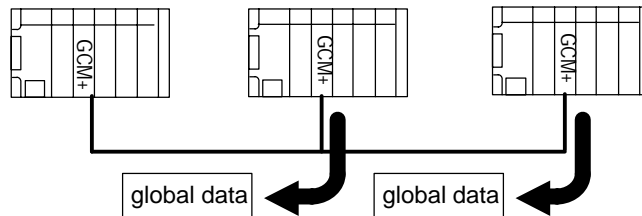

Incoming global data can be placed in %I, %Q, %G, %AI, %AQ, or %R memory in the Series 90-30 PLC. One destination per incoming message is permitted.

For the Series 90-30 PLC, no special programming is needed to start or stop global data.

Chapter 3 explains how global data passes between the Series 90-30 PLC and a GCM+ module. It also describes operation of the Genius bus scan, and explains how to estimate global data timing.

Diagnostics Provided by the GCM+

The GCM+ provides two kinds of diagnostic information. (For more information about these diagnostics features, see chapter 5).

Status Bits: The GCM+ uses 32 status bits in %I memory to indicate the presence or absence of each device on the bus. The status bits also verify operation of the GCM+ itself. Each bit represents one bus device, from bus address 0 in the LSB to bus address 31 in the MSB.

Fault Reports: If this feature is enabled by configuration, the GCM+ will send fault reports to be monitored by a Series 90-70 PLC on the bus. Among the diagnostic information available is the addition or loss of a rack in the Series 90-30 PLC, and the addition or loss of a module. Each Series 90-30 PLC is treated as a remote drop by the Series 90-70 PLC.

Some Special Applications

In addition to basic global data exchange, the GCM+ module can be used for applications such as:

- Data monitoring by a personal or industrial computer.
- Monitoring data from I/O blocks.
- Communications among devices on the bus.
- Emulating remote I/O for the Series 90-30 by allowing another device on the bus to read input data and control output data in a Series 90-30 PLC.

Data Monitoring by a Computer

In the example system below, there are two Series 90-30 PLCs, a Series 90-70 PLC, and a host computer on a bus. Each bus scan, the Series 90-70 PLC sends one global data message to communicate with both of the Series 90-30 PLCs. Each of the Series 90-30 PLCs sends one global data message to communicate with the Series 90-70 PLC and with the other Series 90-30. The host computer acts as a monitor, and reads all global data.

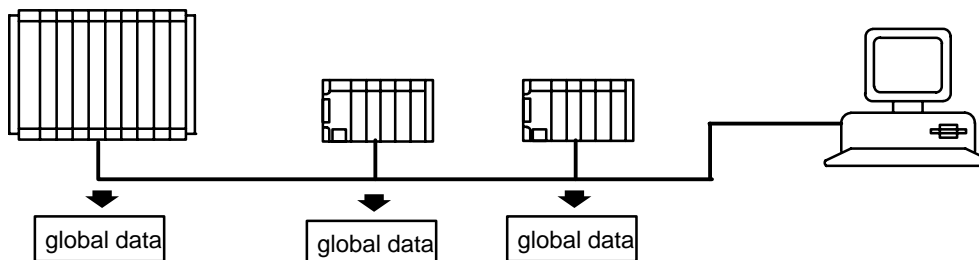

In this system:

- The Series 90-70 PLC broadcasts 100 bytes of global data each bus scan. Within this 100 bytes, the first 60 bytes is data for one Series 90-30 PLC, and the last 40 bytes is data for the other Series 90-30 PLC.
- Each Series 90-30 PLC places the corresponding portion of the data received from the Series 90-70 PLC directly into its host PLC's memory, and discards the rest.
- Both Series 90-30 PLCs send 50 bytes of global data.
- Each Series 90-30 PLC listens to 10 bytes of the other's global data and discards the rest.
- The Series 90-70 PLC automatically receives all Global Data from both Series 90-30 PLCs.

Configuration

Because each of these GCM+ modules receives much more incoming global data than its host PLC needs, the GCM+ module's **offset** and **length** configuration features are used to discard the extra data. For configuration details, see chapter 4.

Monitoring Inputs from I/O Blocks

Devices on a bus may include Genius I/O blocks which are under the control of another type of host (either a PLC or computer). The GCM+ cannot be used to control I/O blocks. However, it is possible for the Series 90-30 PLC to monitor the input data that is broadcast by individual I/O blocks.

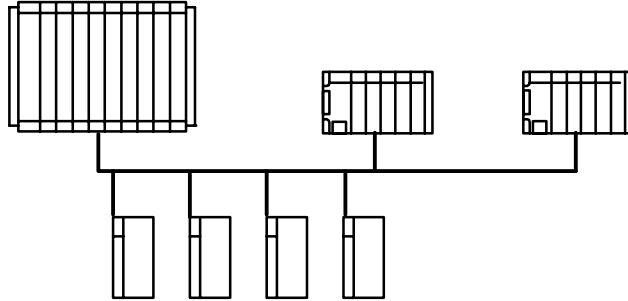

In this system:

- The Series 90-70 PLC controls the operation of the I/O blocks.
- The Series 90-30 PLCs listen to input data from the I/O blocks, but cannot control their outputs.
- All three PLCs exchange global data with each other.

Configuration

The Series 90-30 PLC will receive the input data from block if the block's bus address (SBA) is assigned a length during configuration of the GCM+ module. See chapter 4 for configuration instructions.

Communications Among Bus Devices

In the system represented below, four Series 90-30 PLCs exchange communications via GCM+ modules. Every bus scan, each Series 90-30 sends global data to all of the others. Using the **message length** and **offset** configuration features of the GCM+, each of the other Series 90-30s is able to read a designated 8-byte section of the message and discard the rest.

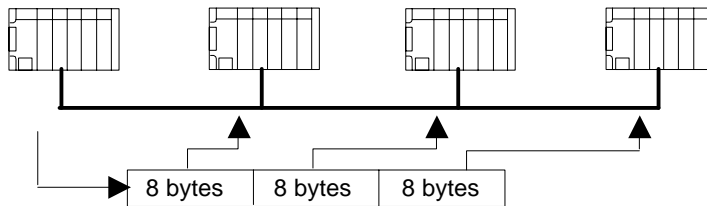

In this example, each Series 90-30 PLC sends its global data from output (%Q) memory, and places incoming global data into input (%I) memory.

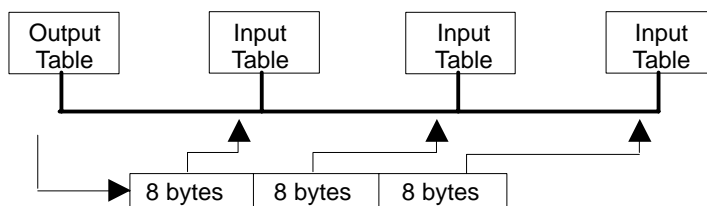

The illustrations represent the global data transmission for one Series 90-30 PLC. In the same bus scan, the three other PLCs also send global data which is read by the others in the same way.

Configuration

Configuration for this type of application is explained in chapter 4.

Using Global Data Communications to Emulate Remote I/O

In this example, four Series 90-30 PLCs exchange data from their I/O tables. One of the PLCs sends output data to the others and receives input data from them in return. Here, the device sending outputs is a Series 90-30 PLC. The device sending outputs could also be a Series 90-70 PLC, a host computer, or a Series Six or Series Five PLC.

PLC Sends Outputs (example)

Every bus scan, the device that controls outputs sends global data. Each of the other PLCs reads its own 8-byte section of the message and discards the rest.

Device that Sends Outputs

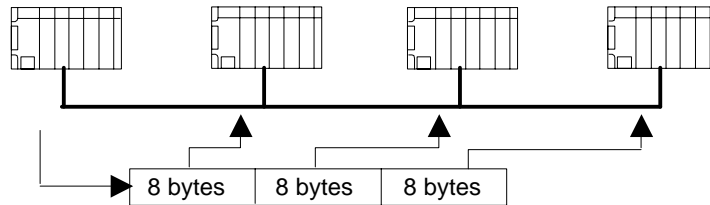

Because the first PLC sends global data from its output table to the output tables of the other PLCs, it can actually control the other PLCs' output devices.

Device that Sends Outputs

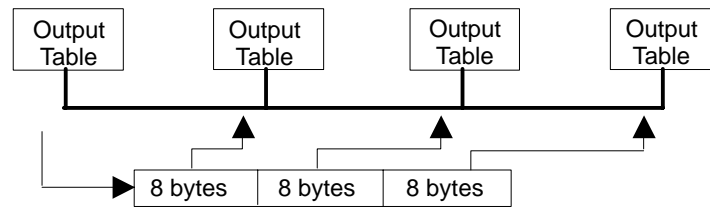

Other PLCs Send Inputs

In the same bus scan, each of the other PLCs sends data from its own input table to the first PLC's input table. The application program in the first PLC can act on these global data inputs as though they were inputs from its own PLC system.

Device that Sends Outputs

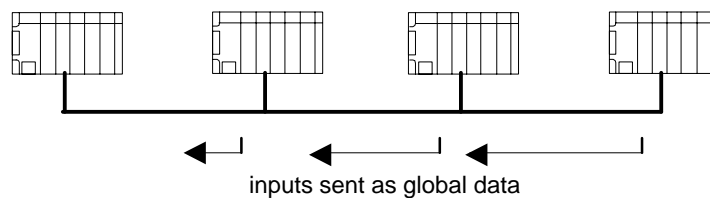

Configuration

Configuration for this type of application is explained in chapter 4.

Chapter 2

Hardware Installation

This chapter explains how to:

- install and remove a GCM+ module
- remove and install the module's Terminal Assembly
- select and install the Bus Cable
- connect and terminate the communications bus
- plan system wiring installation and protect against lightning surges
- install a separate Genius Hand-held Monitor connector on the bus

Module Installation and Removal

The GCM+ module may be installed and removed in the same manner as all other Series 90-30 modules. Power must be OFF when installing or removing the module.

Module Installation

To install the GCM+ module in the Series 90-30 PLC backplate:

1. Grasp the module with the terminal board toward you and the rear hook facing away from you.
2. Align the module with the desired base slot and connector. Tilt the module upward so that the top rear hook on the module engages the slot on the baseplate.
3. Swing the module downward until the connectors mate and the locking lever on the bottom of the module snaps into place, engaging the baseplate notch.

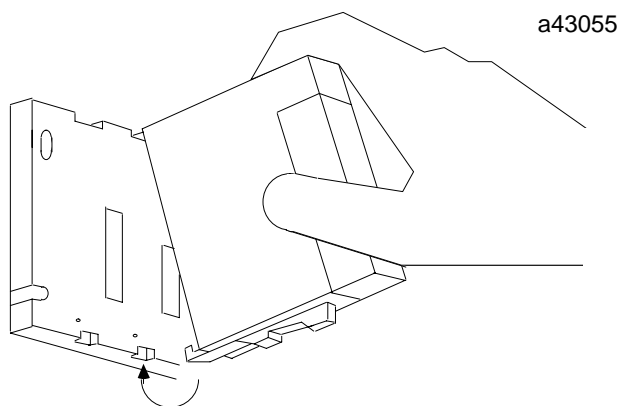

Note the slot number; this number must be entered when the module is configured.

Module Removal

The module can be removed without powering down the communications bus, provided the incoming and outgoing Serial 1 wires have been connected to one terminal and the Serial 2 wires have been connected to one terminal or jumpered as described on the next page. If this has been done, do not disconnect the bus cable or any terminating resistor. Remove the Terminal Assembly from the front of the GCM+ carefully. Avoid contact with exposed cable wiring. Place the Terminal Assembly, with the bus wiring still attached, in a protected location.

Caution

If exposed wiring comes in contact with conductive material, data on the bus may be corrupted, possibly causing the system to shut down.

If the rest of the bus is powered down, the bus wiring can be removed from the module.

To remove the module:

1. Locate the release lever on the bottom of the module. Firmly press it up toward the module.
2. While holding the module firmly at the top, continue fully depressing the release lever and swing the module upward.
3. Disengage the hook at the top of the module by raising the module up and moving it away from the baseplate.

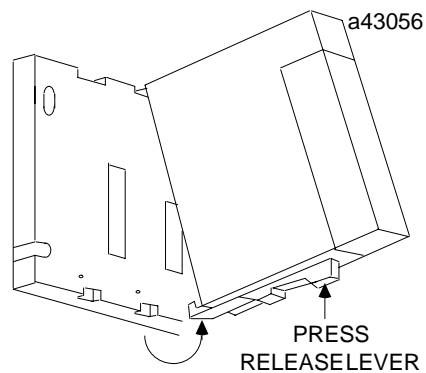

Note

If the Genius bus is operating at 76.8Kbaud, the bus must be properly terminated before powering-up the GCM+ module.

The module will not power up on an unterminated bus at 76.8Kbaud.

Terminal Assembly Removal and Installation

The Terminal Assembly of all Series 90-30 modules can be removed or installed from the module as described below.

Terminal Assembly Removal

1. Open the hinged cover on the front of the module.
2. There is a jacking lever above the wiring terminals, on the left. Push this lever upward to release the terminal block.

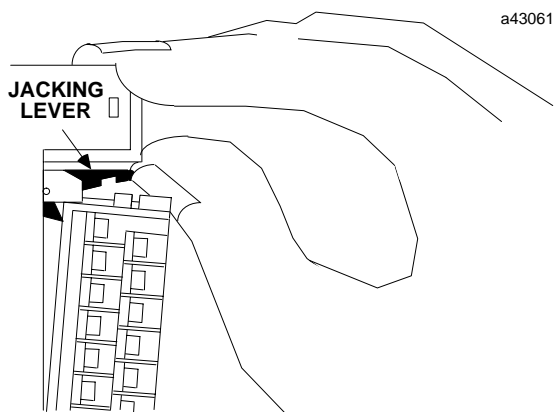

3. Grasp the narrower pull-tab located at the right of the retaining tab. Pull the tab toward you until the contacts have separated from the module housing and the hook has disengaged.

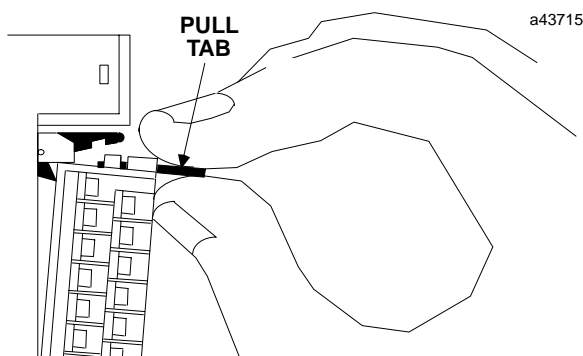

Terminal Assembly Installation

To replace the Terminal Assembly, follow the steps below. If wiring is already in place, be sure that the Terminal Assembly is being connected to the proper type of module.

Caution

Check the label on the hinged door and the label on the module to be sure they match. If a wired Terminal Assembly is installed on the wrong module type, damage to the module may result.

1. If the pull tab at the top of the Terminal Assembly is extended, push it back. Close the Terminal Assembly door.
2. Place the hook at the bottom of the Terminal Assembly into the corresponding slot at the bottom of the module.
3. Pivot the Terminal Assembly upward and firmly press it into position.
4. Open the door and check to be sure that the latch is securely holding the Terminal Assembly in place.

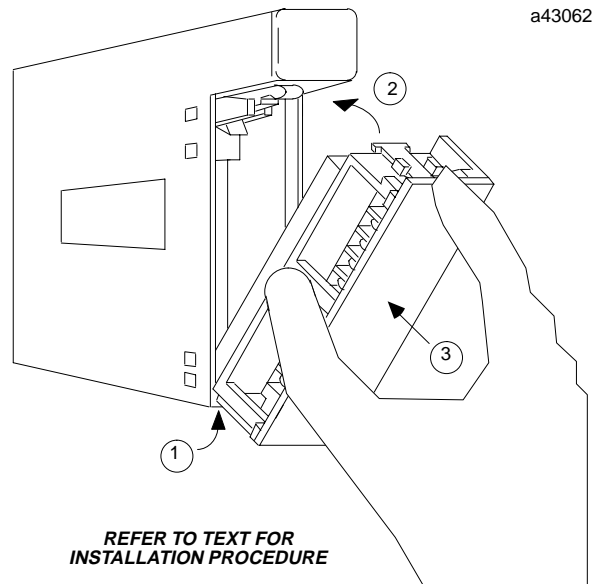

Bus Cable Selection

The Genius bus is a shielded twisted-pair wire, daisy-chained from block to block and terminated at both ends. Proper cable selection is critical to successful operation of the system.

Each bus in the system can be any cable type listed in the table below. Do not mix cables of different impedance, regardless of cable run length. Do not mix cable types in long and/or noisy installations. Other, small-size twisted pair shielded wire of unspecified impedance can be used for short runs of 50 feet or less, using 75 ohm terminations. Selection of wire type may be limited by local and national codes and industry standards. Consult the cable manufacturer to determine the cable's suitability for a particular type of installation.

Conservative wiring practices and national and local codes require physical separation between control circuits and power distribution or motor power. Refer to sections 430 and 725 of the National Electric Code. Also refer to Appendix A for more detailed information about the bus.

Cable # & Make	NEC (USA) Type	Outer Diameter	Terminating Resistor* -10%to+20% 1/2 Watt	Number of Conductors/ AWG	Dielectric Voltage Rating	Ambient Temp Rating	Maximum Length Cable Run, feet/meters at baudrate			
							153.6s	153.6e	76.8	38.4 ●
(A)9823 (C)4596 (M)M39240	none CL2 CM	.350in 8.89mm	150 ohms	2 / #22	30v	60C	2000ft 606m	3500ft 1061m	4500ft 1364m	7500ft 2283m
(B)89182	CL2P	.322in 8.18mm	150 ohms	2 / #22	150v	200C	2000ft 606m	3500ft 1061m	4500ft 1364m	7500ft 2283m
(B)9841 (M)M3993	CM CL2	.270in 6.86mm	120 ohms	2 / #24	30v	80C	1000ft 303m	1500ft 455m	2500ft 758m	3500ft 1061m
(A)9818C (B)9207 (M)M4270	CL2 CM CM	.330in 8.38mm	100 ohms	2 / #20	300v	80C	1500ft 455m	2500ft 758m	3500ft 1061m	6000ft 1818m
(A)9109 (B)89207 (C)4798 (M)M44270	CL2P CM * CMP	.282in 7.16mm	100 ohms	2 / #20	150v	200C	1500ft 455m	2500ft 758m	3500ft 1061m	6000ft 1818m
(A)9818D (B)9815	none *	.330in 8.38mm	100 ohms	2 / #20			1500ft 455m	2500ft 758m	3500ft 1061m	6000ft 1818m
(O)911264 **	none	.260in 6.60mm	100 ohms	2 / #22 flexing	250V	80C	1500ft 455m	2000ft 606m	3000ft 909m	4500ft 1364m
(E)532185 BBDN	CM	approx. .50in (12.7mm)	100 ohms	4 pairs #24 (solid)	>150V	80C	1500ft 455m	2000ft 606m	3000ft 909m	4500ft 1364m
(A)9818 (B)9855 (M)M4230	* CM CM	.315in 8.00mm	100 ohms	4 (two pair) #22	150v	60C	1200ft 364m	1700ft 516m	3000ft 909m	4500ft 1364m
(A)9110 (B)89696 (B)89855	none CMP CMP	.274in 6.96mm	100 ohms	4 (two pair) #22	150v	200C	1200ft 364m	1700ft 516m	3000ft 909m	4500ft 1364m
(A)9814C (B)9463 (M)M4154	none CM CL2	.243in 6.17mm	75 ohms	2 / #20	150v	60C	800ft 242m	1500ft 455m	2500ft 758m	3500ft 1061m
(A)5902C (B)9302 (M)M17002	none CM CM	.244in 6.20mm	75 ohms	4 (two pair) #22	300v	80C	200ft 60m	500ft 152m	1200ft 333m	2500ft 758m

Notes: A = Alpha, B = Belden, C = Consolidated, E = Essex, M = Manhattan, O = Olflex
 ● = Limited to 16 taps at 38.4 Kbaud
 * = not known
 ** = Suitable for applications requiring high flexibility continuous flex or vibration.

NEC classes are based on data obtained from manufacturers and are subject to change. CANADIAN CEC codes are generally similar. Other countries may vary. The serial bus can be treated as a Class 2 circuit when appropriate wiring practices are followed. Maximum available bus lengths may be affected when installation requires the high voltage rated CM (Communications) rating. CM types can replace CL2, but not vice versa.

Using Other Cable Types

The cable types listed in the preceding table are recommended for use. If the cable types listed above are not available, the cable selected must meet the following guidelines.

1. High quality construction. Most important is uniformity of cross section along the length of the cable. Poor quality cable may cause signal distortion, and increase the possibility of damage during installation.
2. Precision-twisted shielded wire of EIA RS422 standard type, having a uniform number of twists per unit of length. In a catalog, this type of cable may also be listed as twinaxial cable, data cable, or computer cable.
3. Relatively high characteristic impedance; 100 to 150 ohms is best; 75 ohms is the minimum recommended.
4. Low capacitance between wires, typically less than 20pF/foot (60pF/meter). This may be accomplished by inner dielectrics of foamed type, usually polypropylene or polyethylene, having a low dielectric constant. Alternatively, the conductors may be spaced relatively far apart. Lower impedance types have smaller cross-sections, and provide easier wiring for shorter total transmission distances.
5. Shield coverage of 95% or more. Solid foil with an overlapped folded seam and drain wire is best. Braided copper is less desirable; spiral wound foil is least desirable.
6. An outer jacket that provides appropriate protection, such as water, oil, or chemical resistance. While PVC materials can be used in many installations, Teflon, polyethelene, or polypropylene are usually more durable.
7. Electrical characteristics: cable manufacturers' information about pulse rise time and NRZ data rate is useful for comparing cable types. The Genius bit consists of three AC pulses; the equivalent NRZ bit rate is about three times as great.

For assistance in selecting a cable type, please consult your local GE Fanuc application engineer.

Bus Length

The maximum bus length for shielded, twisted-pair cable is 7500 feet. Some cable types are restricted to shorter bus lengths. If the application requires greater bus length, fiber optics cable and modems can be used. For more information, see the *Genius I/O System and Communications Manual*.

Baud Rate Selection

The bus length determines which baud rate may be selected. A Genius bus can operate at one of four baud rates: 153.6 Kbaud standard, 153.6 Kbaud extended, 76.8 Kbaud, or 38.4 Kbaud. The baud rate selected should be indicated on all devices, especially if different busses in the facility use different baud rates. The baud rate must be configured using a Hand-held Programmer or the system configuration software.

Note that in noisy environments, 153.6 Kbaud extended provides improved noise immunity with little effect on bus scan time. If a system is experiencing excessive blinking of the bus controller's COMM OK light, or if the I/O blocks' I/O Enabled LEDs go off frequently, 153.6 Kbaud extended should be used.

Bus Installation

The Genius bus is connected to the terminal assembly on the front of the GCM+ module. For the GCM+ module, these terminals have the following assignments:

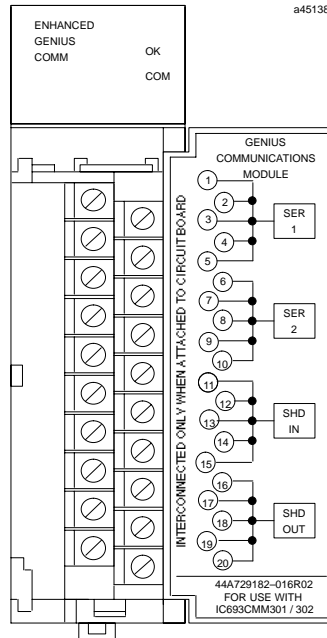

Connection can be made to any of the terminals in a group. The cable is routed to and from the terminals via the bottom of the Terminal Assembly cavity.

Using the cable type selected for the application, connect the Serial 1 terminals of adjacent devices and the Serial 2 terminals of adjacent devices. Connect Shield In to the Shield Out terminal of the previous device. Connect Shield Out to the Shield In terminal of the next device. For the first device on the bus, Shield In is not connected. For the last device on the bus, Shield Out is not connected.

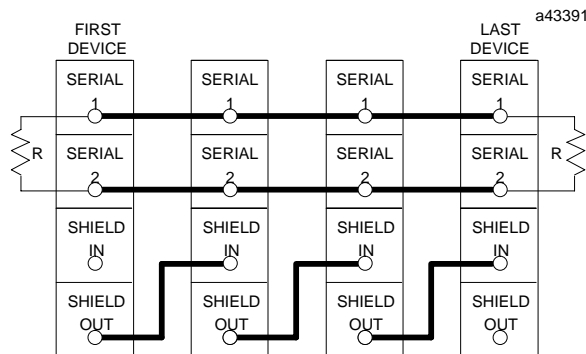

Each terminal will accept up to one AWG #14 wire or two AWG #16 wires using ring or lug-type connectors.

The bus shield wires are not insulated; do not permit them to touch other wires or terminals. The use of spaghetti tubing for this purpose is recommended.

Serial Wire Connections

The Serial 1 and Serial 2 terminals are interconnected *on the circuit board*, not on the terminal strip. Incoming and outgoing signal wire pairs can be connected to either one or two Serial 1 or Serial 2 terminals:

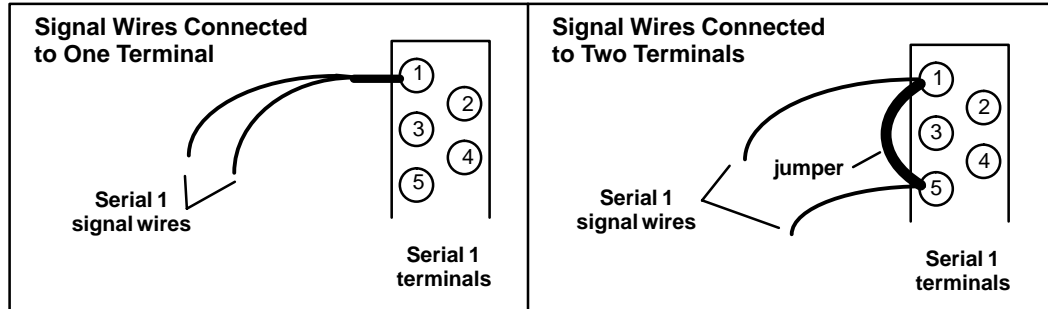

If you are connecting two signal wires to the same terminal, use spade or lug-type connectors, or twist the exposed ends of the wires together before inserting them. This will allow future removal of the Terminal Assembly without disrupting other devices on the bus (see *Module Removal*, in this section).

If you are connecting two signal wires to separate terminals, install a jumper between the two terminals as shown on the right above. Failure to install the jumper will cause the entire bus to be disrupted whenever the faceplate is removed.

Terminating the Bus

The bus must be terminated at both ends by its characteristic impedance. The list of cable types in chapter 3 includes the termination requirements for each cable type. If the GCM+ is at the end of the bus, install a resistor of the appropriate impedance across its Serial 1 and Serial 2 terminals as shown below.

If you need to install the terminating resistor across different terminals than those used for the signal wires, attach jumper wires between the signal wire terminals and the resistor terminals to prevent the bus from becoming unterminated if the Terminal Assembly is removed. Failure to do so will cause the entire bus to be disrupted whenever the faceplate is removed.

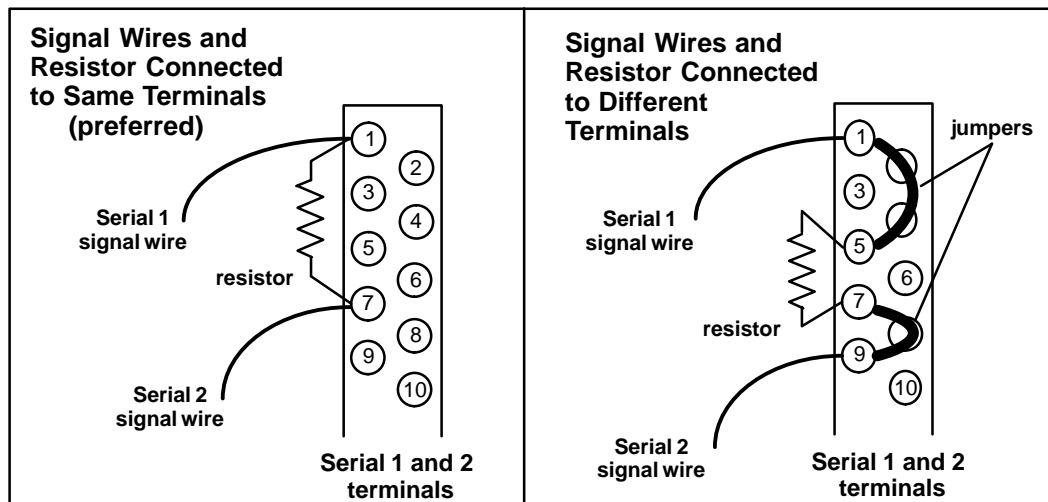

Wiring Guidelines

Four types of wiring may be encountered in a typical factory installation:

1. Power wiring – the plant power distribution, and high power loads such as high horsepower motors.
2. Control wiring – usually either low voltage DC or 120 VAC of limited energy rating. Examples are wiring to start/stop switches, contactor coils, and machine limit switches. This is generally the interface level of the Genius discrete I/O.
3. Analog wiring – transducer outputs and analog control voltages.
4. Communications and signal wiring – the communications network that ties everything together, including computer LANs, MAP, and the Genius communications bus.

These four types of wiring should be separated as much as possible to reduce the hazards from insulation failure, miswiring, and interaction (noise) between signals. A typical PLC system may require some mixing of the latter three types of wiring, particularly in cramped areas inside motor control centers and on control panels. In general, it is acceptable to mix the Genius bus cable with the I/O wiring, as well as associated control level wiring. All noise pickup is cumulative, depending on both the spacing between wires and the distance span they run together. I/O wires and Genius bus cable can be placed randomly in a wiring trough for lengths of up to 50 feet. If wiring is cord-tied (harnessed), do not include the bus cable in the harness, since binding wires tightly together can damage some cable types.

Wiring external to equipment and in cable trays should be separated following NEC practices.

Lightning Transient Suppression

Running the bus cable outdoors or between buildings may subject it to lightning transients beyond the 1,500 volt transient rating of the system. Installing cable underground reduces the probability of a direct lightning strike. However, buried cables can pick up hundreds of amperes of current when lightning contacts the ground nearby.

Therefore, it is important to protect the installation by including surge protectors on underground data lines. The cable shields should be grounded directly. Surge suppressors and spark gaps should be used to limit the voltage that might appear on the signal lines. It is recommended to install two (only) silicon surge suppressors or spark gaps to control transients of 1 to 25 Kilovolts from 100 to 1000 amps or more. These devices should be installed close to the entrance of the bus to the outdoors.

Silicon Surge Suppressors are available many sources, including Clare/General Instruments and Motorola, For information about this product, in the US contact Lucas Industries Incorporated, 5500 New King Street, Troy, Michigan 48098. Spark gaps are available from Clare. Refer to the vendor's literature for installation details.

In extreme situations such as totally-isolated power systems, additional protection against lightning damage should be provided by adding surge suppressors for groups of I/O blocks. Such suppressors should be installed from incoming power leads to ground (enclosure baseplate/block case where leads enter the enclosure).

A device specifically designed to protect the Genius bus is available from CONTROL TECHNOLOGY, 835 Hwy 90, Hancock Square Suite 10 (P. O. Box 2908), Bay Saint Louis, MS 39520. (tel 601 466- 4550, fax 601 466- 4553). Contact them for application information. The device must be used in combination with power line suppression to fully protect the system.

Installing a Hand-held Monitor Connector

The GCM+ does not have a built-in connector for a Genius Hand-held Monitor. However, a Hand-held Monitor connector can be added directly to the serial bus at any location.

The unit shown below (catalog number 44A736310-001-R001) provides a Hand-held Monitor connector and serial bus terminals in a single convenient package.

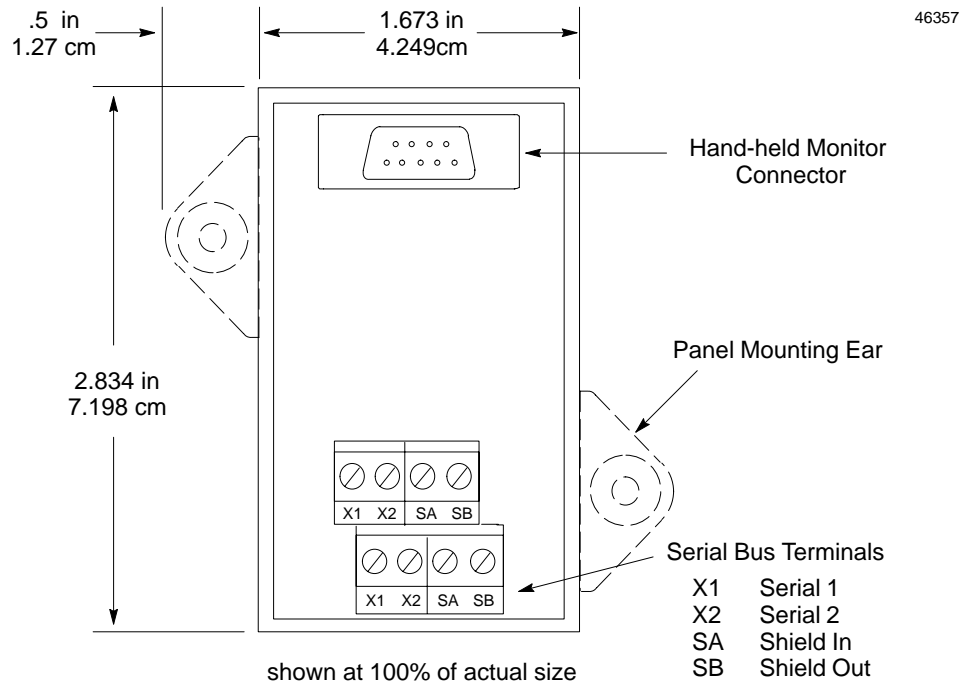

Mounting the HHM Connector

This unit can be easily mounted on a rail such as a standard 35mm or 15mm DIN rail. The panel-mounting ears are not used if the unit is installed on a DIN rail.

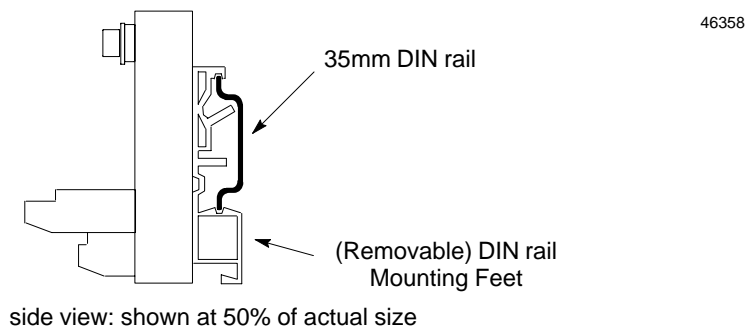

Alternatively, it can be installed directly on a panel using screws through its mounting ears. The DIN rail feet on the back of the unit are removed when the unit is panel-mounted.

Making the Bus Connections

The Hand-held Monitor connector has two sets of terminals; one for incoming cable and the other for outgoing cable.

Connect the Serial 1, Serial 2, and Shield In terminal of either connector to the previous device. Connect the Serial 1, Serial 2, and Shield In terminal of the other connector to the next device.

The following illustration shows connections for incoming and outgoing serial bus cable. As with other devices, the HHM connector can be at either end of its bus. If it is, there will only be one bus cable attached.

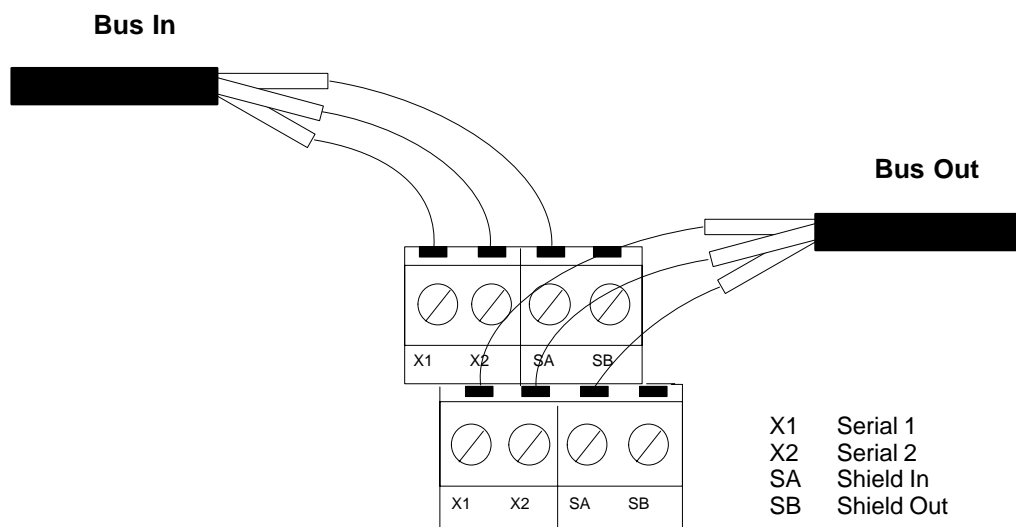

As with other devices, if the Hand-held Monitor Connector is at either end of its bus, install an appropriate terminating resistor across the Serial 1 and Serial 2 terminals.

Installing the Hand-held Monitor D-Shell Connector on the Bus

You have the option of installing the D-shell connector that is supplied with the Hand-held Monitor.

1. Using the mounting plate as a template, cut an opening in the panel for the mating connector. Also drill two holes for the mounting hardware.
2. Attach the mounting plate and mating connector to the panel using the mounting hardware supplied.
3. Secure the two ends* of the serial bus cable to the back of the panel using strain relief brackets.
4. Strip the ends of the wires. Twist the two Serial 1 wires together and attach them to pin 5 of the connector. Twist the Serial 2 wires together and attach them to pin 9. Similarly, attach the Shield wire(s)* to pin 4.

The following illustration shows connections for incoming and outgoing serial bus cable. As with other devices, the HHM connector may be at either end of its bus. If it is, there will only be one bus cable attached.

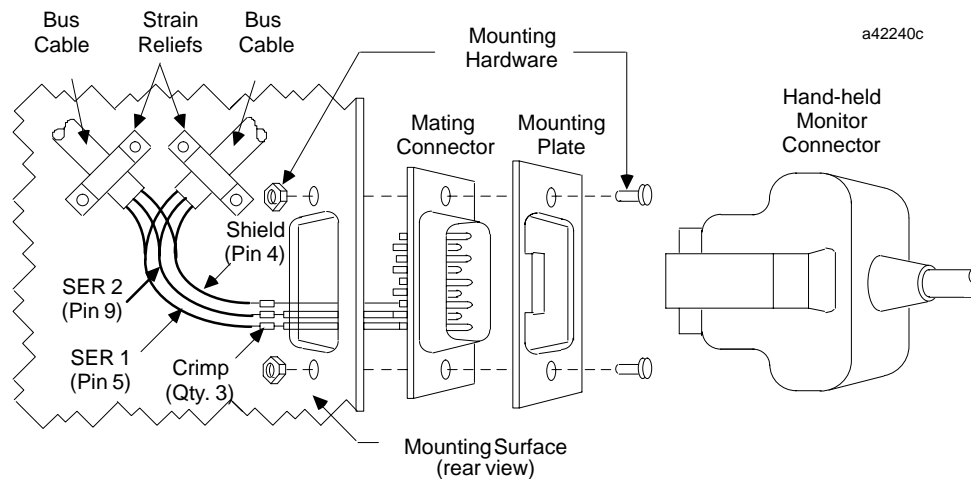

When making bus connections, the maximum exposed length of bare wires should be two inches. For added protection, each shield drain wire should be insulated with spaghetti tubing to prevent the Shield In and Shield Out wires from touching each other.

If the Hand-held Monitor connector is at either end of its bus, it is necessary to install an appropriate terminating resistor across the Serial 1 and Serial 2 wires.

Chapter 3

Operation & Timing

This chapter explains:

- How the GCM+ sends and receives global data.
- What happens to global data if some communications stop.
- Application programming needed for global data.
- The relationship between the bus scan and the CPU sweep.
- How other devices handle global data received from the GCM+.
- How to estimate bus scan time.
- How to estimate data response time.
- How to avoid unnecessarily slowing down both the CPU sweep time and the scan time of the Genius bus.

How the GCM+ Handles Global Data

The GCM+ can send global data to all the other global Genius devices on the bus. It can also automatically pass to the CPU any global data that has been sent by any other devices on the same bus.

Global data can be sent from and received into the following memories in the Series 90-30 PLC: %G, %I, %Q, %AI, %AQ, and %R. Status data uses %I memory.

GCM+ Receives Global Data

The GCM+ passes to the CPU global data from all devices for which a length has been configured.

In the following example, two devices (at Bus Addresses 18 and 22) send global data on the bus. Each module broadcasts its global data while it has the bus token. The global data is received by a GCM+ module in a Series 90–30 PLC (#20 in the diagram).

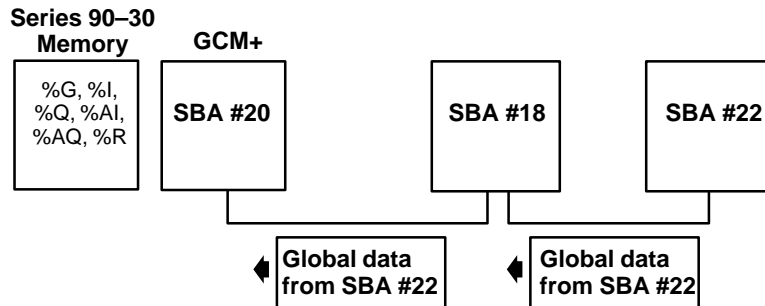

The GCM+ module stores the global data it receives. When the Series 90–30 CPU executes the input update portion of its sweep, it reads both global data and status bits (see below) from the GCM+.

In this example, the PLC CPU copies global data from the GCM+ into the memory locations configured for the devices at Bus Addresses 18 and 22.

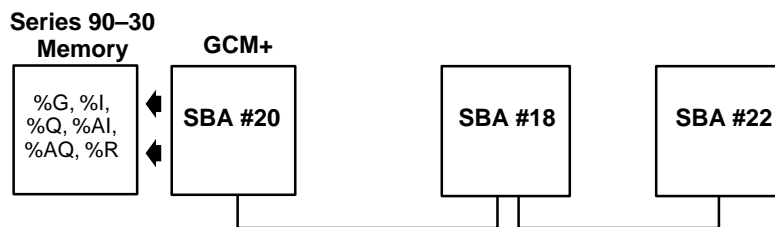

What Happens If Incoming Global Data Stops

As part of the GCM+ configuration a **data default** selection (OFF or Hold Last State) must be configured. If the GCM+ stops receiving global data from any device(s) for which a global data length has been configured, the GCM+ sets the corresponding memory locations to the selected default. If the default is OFF, the GCM+ supplies 0s for the missing data. If the default is Hold, the GCM+ continues to supply the last set of valid data it received.

Status Bits

The GCM+ maintains a status bit for every potential bus device. Those bits are set to 1 for every device that sends global data. If the GCM+ does not receive, or stops receiving, communications from any device, its bit is set to 0. In addition, it defaults the data as described above. The configuration supplied to the GCM+ must provide a location in %I in which to place the 32 status bits. The status bits are updated every PLC sweep.

GCM+ Sends Global Data

If there is an application program running in the 90–30, it executes before the PLC CPU updates outputs. During the output portion of the sweep, if the GCM+ is configured to send global data, the PLC CPU also writes the content of the selected memory location to the GCM+.

Continuing the same example, the CPU sends new global data to its GCM+ from the memory location configured for Bus Address 20.

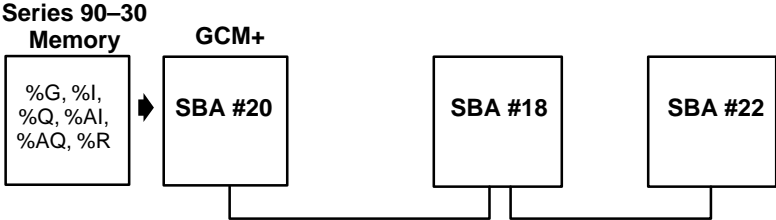

The GCM+ module stores this data until it receives the bus token. At that time, it broadcasts the global data to all the other devices on the bus.

In the example system, both Bus Addresses 18 and 22 will receive the global data sent from Bus Address 20:

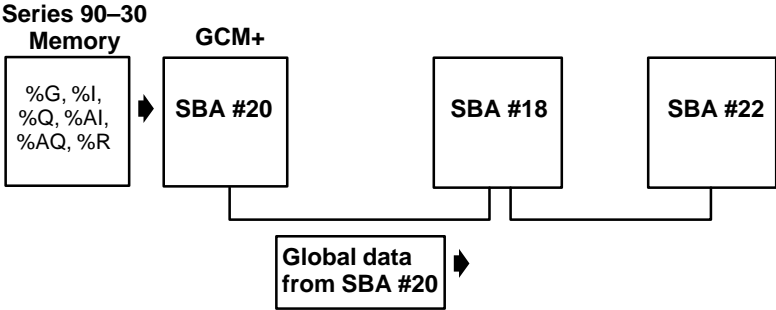

What Happens If the CPU Stops Supplying Global Data

As mentioned above, a **data default** of OFF or Hold Last State must be selected. If the GCM+ stops being scanned by the Series 90–30 PLC CPU, it defaults its outgoing global data. If the default is OFF, it sends all 0s. If the default is Hold, it continues to send the last set of valid data it received from the CPU.

Global Data Without an Application Program

The Series 90–30 can transmit and receive global data with or without running an application program. Configuring I/O modules in the Series 90–30 to have the same reference addresses used for global data allows the I/O modules to effectively exchange I/O data with another device on the bus. Thus, where it is desired to set up the Series 90–30 PLC without a program, incoming data to the GCM+ will be mapped to %Q and %AQ (where output modules are also mapped) and outgoing global data will be mapped to %I or %AI (where input modules are also mapped).

How Other Devices Handle GCM+ Global Data

Global data sent by a GCM+ can be received by any other GCM+, bus controller, PCIM, QBIM, or GCM on the bus. All of the devices will receive the same global data message from the GCM+. How each type of device handles the message is summarized below.

- Series 90–30 PLC GCM+ Module or Bus Controller** A GCM+ or bus controller in another Series 90–30 PLC places the data in the memory location specified when that GCM+ or bus controller is configured. If the GCM+ or bus controller does not need all of the data, a message offset and length can be specified.
- Series 90–30 PLC GCM Module** The Series 90–30 Genius Communications Module (GCM) uses specific %G memory locations for global data. It places incoming global data in the %G memory location corresponding to Device Number (16–23) of the device that sent the data. The GCM will not receive global data sent from SBAs 0 to 15 or 24 to 31.
- Series 90–70 PLC** The Series 90–70 PLC places incoming global data into the memory location selected during configuration of its bus controller.
- Series Six PLC** If a Series Six Reference is specified during GCM+ configuration, any Series Six and/or Series Five PLC on the bus will automatically receive all global data from the GCM+ and place it in that register location.
- Series Five PLC** See Series Six PLC.
- Computer** Data from the GCM+ is placed into the PCIM or QBIM Input Table Segment corresponding to the Bus Address of the GCM+. The computer's application program is responsible for transferring global data between the CPU and the PCIM or QBIM.
- I/O Blocks** I/O blocks (controlled by another host) can be present on the bus, but they cannot receive global data.

Timing Considerations

Communications on the Genius bus occur by a method called “token passing”. The devices on the bus pass an implicit token, which rotates among the devices in sequence from bus address 0 to bus address 31. Unused bus addresses (SBAs) are passed with very slight delays. This sequence is called a bus scan. After device 31 has had its turn, the scan restarts at device 0.

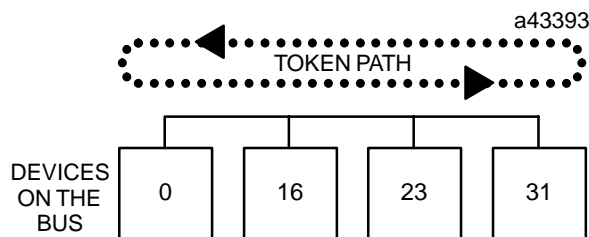

Each device on the bus can listen to messages at all times (not just when it has the token). A GCM+ module listens to all broadcast messages. These are messages that are sent to all devices on the bus. Global data is a type of broadcast message.

While each device holds the token, it can send messages. To end its turn, the transmitting device sends one specific broadcast message which acts as a sign-off message, and the token passes to the next device.

Bus Scan Time and CPU Sweep Time

Global Data adds to both the CPU sweep time in the Series 90-30 and to the scan time of the Genius bus. You can estimate the CPU sweep time and bus scan time added by global data, and the time it can take for a Series 90-30 PLC to send global data and then receive a response based on that data.

If CPU sweep time is slower than bus scan time, it is possible that some incoming global data might change before it is picked up by the CPU. It is important to be sure that the data will not be sent so briefly that it will be missed.

If program execution time is faster than bus scan time, the CPU may process the same data repeatedly. Also, if output data changes too quickly, some outputs may change before they are sent out on the Genius bus.

The *Series 90-30 PLC Installation Manual* (GFK-0356) explains how you can estimate bus scan time.

Bus Scan Time for Global Data

The minimum amount of time required for the token to make a complete bus rotation is 3mS. This minimum time limit is imposed by the GCM+ and other types of bus interface modules. The maximum possible bus scan time is 400mS, but this will never be reached under normal circumstances.

The presence of other PLCs, a host computer, I/O blocks, or datagrams on the bus adds to the bus scan time (although the time required for each individual message transmission remains the same). Using one of the slower baud rates also increases bus scan time. The scan time increase from 153.6 Kbaud standard to 153.6 Kbaud extended is slight. But scan time is about twice as long at 76.8 Kbaud and four times as long at 38.4 Kbaud.

Estimating Bus Scan Time

If you want to estimate bus scan time, follow the instructions below for GCM+ modules. If the bus also has other types of controllers or Genius I/O blocks, you will need additional information from the *Genius I/O System User's Manual*.

1. First, **add up the time needed to service all 32 possible bus addresses** (including unused bus addresses), at the bus baud rate. See the table below.

Device Type	Contribution time in mS at each baud rate			
	153.6 Kb std	153.6 Kb ext	76.8 Kb	38.4 Kb
GCM+	0.586	0.658	1.324	2.655
Unused Bus Address	0.026	0.052	0.104	0.208

2. Next, **find the total amount of global data transmitted each bus scan**. For example, if two GCM+ modules each send a 24-byte global data message and there is no other global data on the bus, the total is 48 bytes.
3. **Multiply the total amount of global data by the transmission rate:**
 - 0.0715ms per byte for 153.6 Kbaud (either standard or extended)
 - 0.143ms per byte for 76.8 Kbaud
 - 0.286ms per byte for 38.4 Kbaud

Example

A bus has eight GCM+ modules and no other devices. Each GCM+ sends 24 bytes of global data. The baud rate 153.6 Kbaud standard.

8 GCM+ modules (8 x 0.586)	4.688ms
24 unused Device Numbers (24 x 0.026)	0.624ms
8 global data messages, 24 bytes each ((8 x 24) x 0.0715)	<u>13.728mS</u>
Total bus scan time =	19.040mS

Reducing Bus Scan Time

Bus scan time can be shortened by reducing the number of devices on the bus, reducing the amount of global data transmitted, or both.

Estimating Data Response Time

If you want to find out approximately how long it will take for one module to send global data to another and to receive a response based upon that data, add together the maximum times that may be required for each portion of the input to output cycle.

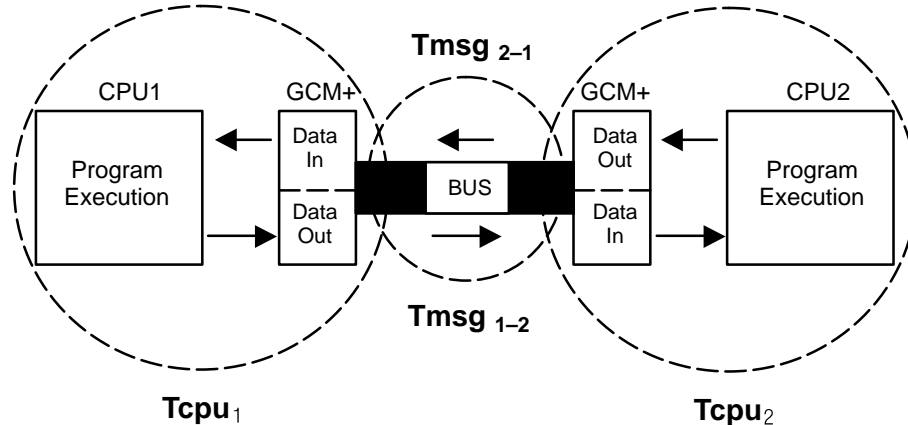

The equation to use when calculating response time is:

$$2(Tcpu_1) + (Tmsg_{2-1} + Tmsg_{1-2}) + 2(Tcpu_2) = \text{response time}$$

Bus Scan Time (Tmsg)

Whenever a GCM+ gets its turn on the bus, it obtains the latest global data from the Series 90-30 PLC CPU, then transmits that data on the bus. An application program normally will process the incoming global data before preparing a response. In the worst case, this will result in the response being sent on a separate Genius bus scan. Thus, from CPU₁ to CPU₂ there is a delay of Tmsg₁₋₂ and from CPU₂ to CPU₁ there is a delay of Tmsg₂₋₁. Calculate Tmsg for a GCM+ by going through steps 1, 2, and 3 on the previous page. Don't include unused bus addresses.

CPU Time (Tbus) for Each CPU

A GCM+ module stores incoming global data where it can be accessed by the application program currently executing in the CPU. If the CPU services the module shortly after it receives new global data, the data is read into CPU memory quickly. However, if the GCM+ module has just been serviced by the CPU, the global data won't be read until the next sweep. The worst-case delay is therefore Tcpu.

If the application program will send global data in response to global data it has received, one additional CPU sweep is needed for the application program to process the data and update the GCM+. Again, this represents a delay of Tcpu. Total delay time within each CPU is 2Tcpu.

Chapter 4

Configuration

This chapter describes:

- Configuration parameters of the GCM+
- Configuration steps for the GCM+ using a Series 90-30 Hand-held Programmer

The GCM+ must be physically present to be configured by a Hand-held Programmer (HHP). It does not have to be present if it will be configured using the system configuration software. The HHP may be used to enter, change, or remove a GCM+ configuration. The HHP will work whether the Series 90-30 was previously configured with the system configuration software to include a GCM+ or not. Note that a Genius Hand-held Monitor cannot be used to configure a GCM+.

Initial Configuration

An unconfigured GCM+ may be installed in a Series 90-30 PLC and connected to the Genius bus. Until such time as it is configured, it will not communicate on the Genius bus and will not exchange any data with its host CPU. To configure the GCM+, the CPU must be in Stop mode.

Global Data Transmissions during Reconfiguration

Configuration data is stored by the PLC. Once defined, the configuration cannot be altered without stopping the PLC. Note that placing the PLC in Stop mode for reconfiguration does *not* stop the GCM+ from sending global data. The content of the data depends on the modules's configured **data default**. If its data default is OFF, the GCM+ sends all 0s each bus scan. If its data default is Hold Last State, the GCM+ sends a copy of the last valid set of data it received from the CPU.

You can prevent the GCM+ sending default data during reconfiguration by temporarily removing it from the bus. The bus wiring must have been installed as described in chapter 2 so that the bus is not "broken" by removal from the GCM+ . The recommended configuration sequence is:

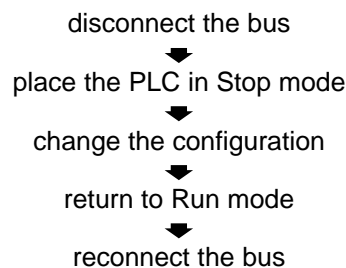

After you finish reconfiguration and return to Run mode, the GCM+ starts sending new global data as soon as it is supplied by the PLC CPU.

Starting Hand-held Programmer Configuration

For Hand-held Programmer configuration, the PLC must be in Stop mode. If necessary, press the **RUN** key on the Hand-held Programmer to change the PLC mode to Stop.

```
PRESS<-/+KEY <R
```

The < R in the upper right corner of the screen indicates that the PLC is in Run mode. Press the -/+ key.

```
RUN MODE <R
```

Press the -/+ key again

```
STOP MODE <R
```

Press the **ENT** key. The screen shows:

```
1. PROGRAM <S
2. DATA
```

The < S in the upper right corner of the screen indicates that the PLC is in Stop mode. Select module configuration by pressing the 4 key, then the **ENT** (enter) key.

Select the GCM+

From the Program/Data screen, select module configuration by pressing the 4 key, then the **ENT** (enter) key.

Press the **Down Arrow** key to reach the configuration screen for the rack and slot location of the GCM+. If the GCM+ is already configured, it appears in the slot location.

```
R0:05 GC+ <S
I32:I0033-I0064
```

The top line indicates the baseplate (RO) and slot (:05) selected. GC+ stands for Enhanced Genius Communications Module. The bottom line shows the addresses in %I memory that are assigned to the status bits. If you press the **Right Arrow** key, this screen appears:

```
R0:05 GC+ <S
SBA: 16
```

Line 2 of the screen shows module's Bus Address (SBA).

If the GCM+ was not previously configured, but is present in the rack and slot, it does not appear at first. The HHP indicates that the slot is "empty".

```
R0:05 EMPTY <S
```

Press the **READ/VERIFY** key, then the **ENT** key.

HHP Error Messages

The Hand-held Programmer will display a message if you make an error during configuration, or if the GCM+ is not present or not communicating with the host PLC.

REF ER	<p>May indicate either of the following:</p> <ul style="list-style-type: none"> A. The reference address assigned to that SBA exceeds the reference limit for the PLC model. B. The SBA message offset plus the length of the reference assigned to the SBA exceed 128 bytes.
REF ADJ	<p>May indicate either of the following:</p> <ul style="list-style-type: none"> A. References have been adjusted (rounded) down to a byte boundary. B. For discrete references, the reference length for the SBA has been rounded up to a byte boundary.
GCM ERR	<p>May indicate either of the following:</p> <ul style="list-style-type: none"> A. Too many GCM+ modules have been configured (the limit is 3). B. You have tried to configure a GCM+ module and a GCM module in the same PLC. The GCM+ cannot be installed in the same PLC as a GCM module.
IOM ERR	The GCM+ module is not available.
I/O ERR	You have assigned reference addresses that overlap references already assigned.
DAT ERR	A parameter (such as the Series Six reference address) is out of bounds.

Configurable Features of the GCM+

Configuration supplies the following setup information for a GCM+:

Parameter	Default	Choices	Comments
Slot number of the GCM+	none	Any Series 90-30 rack slot	
SBA	16	0 - 31	Bus Address
Drop ID	33	16 - 254.	Optional. Used with the Report Faults feature.
Baud Rate	153.6 Kb st.	153.6 Kb standard or extended, 76.8 KB, or 38.4 Kb.	All devices on the bus must use the same baud rate.
Data Default	Off	Off or Hold Last State	Determines data content if communications are lost.
Report Faults	No	Yes or No	Optional. Used to send Fault Reports to a Series 90-70 PLC.
S6 Reference	0	1-16,383	Optional. For sending global data to a Series Six or Series Five PLC.
Status	%I0001	Any available %I reference in host.	Requires 32-bit memory space.
Starting Reference	see text.	Any available %I, %Q, %G, %AI, %AQ, or %R reference in host.	One table memory type per message.
Reference Length	0	0 - 64 words or 0 to 1024 bits in selected host memory.	A length must be specified to exchange global data.
Message Buffer Byte Offset	0	0 - 128 bytes.	Optional. Used to skip the start of an incoming global data message. The configured offset plus length should not exceed the end of the message.

Status

This is the beginning address of a 32-bit status area in the %I memory of the Series 90-30 PLC where the GCM+ can locate status information.

Hand-held Programmer Configuration

```
R0:05 GC+    <S
I32:I  _
```

Enter the beginning reference in %I memory for the GCM+ module's 32 status bits. It is not necessary to enter leading zeros. After entering the number, press the **Enter** key. The HHP displays the range of selected status bit addresses. For example:

```
R0:05 GC+    <S
I32:I0001-I0032
```

Press the **Right Arrow** key to go to the next configuration screen.

Bus Address (Device Number)

Each Genius communications bus can serve up to 32 devices, which are identified by a Bus Address (sometimes called a Device Number) from 0 to 31. By convention, certain numbers are associated with specific types of devices. For example, Bus Address 0 is normally used for a Genius Hand-held Monitor. The Series 90-70 PLC and the Series Six PLC use Bus Addresses 30 and 31 for Bus Controllers in a backup (redundancy) type of system. The Series 90-30 Genius Communications Module, an earlier version of the GCM+, uses Bus Addresses 16 through 23 for global data.

Hand-Held Programmer Configuration

If the Bus Address shown is not correct for this GCM+, enter the new number from the keypad. Press the ENT key to display the new Bus Address. For example:

```
R0:05 GC+ <S  
BUS ADDR: 17
```

To continue configuring the same module, press the **Right Arrow** key.

Baud Rate

All devices on a bus must be configured to use the same baud rate: 153.6 Kbaud standard, 153.6 Kbaud extended, 76.8 Kbaud, or 38.4 Kbaud. The module is set to operate at 153.6 Kbaud standard when shipped from the factory.

Baud rate must be selected on the basis of cable type (see the table in chapter 2) and the following considerations.

1. If the cable length is less than 2000 feet, either 153.6 Kbaud standard or 153.6 Kbaud extended can be used. The use of 153.6 Kbaud extended is recommended, especially if the system will include a dual bus with Bus Switching Modules.
2. If cable length is between 2000 and 3500 feet, select 153.6 Kbaud extended.
3. If the cable length is between 3500 and 4500 feet, select 76.8 Kbaud.
4. If the cable length is between 4500 and 7500 feet, you must select 38.4 Kbaud. This data rate only supports a maximum of 16 device on the bus.
5. If there are any older Genius products on the bus (catalog numbers IC660CBDnnn, IC660CBSnnn, IC660CBAAnnn, IC660HHM500, or IC660CBB900/901), the bus must be set up to use 153.6 Kbaud standard.

Hand-Held Programmer Configuration

Pressing the right arrow key once from the Bus Address screen shows the currently-configured baud rate. For example:

```
R0:05 GC+ <S  
BAUD:153.6KSt
```

If the baud rate shown is not correct, press the +/- key to change it. When the correct baud rate appears, press the **Enter** key then the **Right Arrow** key to display the next configurable feature of the module.

Series Six Reference

This entry can be used to specify a beginning register to be used by a Series Six or Series Five PLC for global data received from the GCM+.

All Series Six and Series Five PLCs on the bus will use this reference. The range of registers available for global data use is 1 to 16,383. A Series Six or Series Five PLC will figure out the length automatically and will require this amount of register space for global data.

If a previously-configured Series Six or Series Five PLC should no longer receive global data from a GCM+, this should be set to 0.

Hand-Held Programmer Configuration

If there is a Series Six or Series Five PLC on the bus that should receive global data from the GCM+, enter a register number here.

If a previously-configured Series Six or Series Five PLC should no longer receive global data from a GCM+, enter 0.

R0:05	GC+	<S
S6	REF:	

Data Default

This parameter determines how the GCM+ will respond if it loses communications. Data will either HOLD its last state, or be set to 0 (OFF). If the GCM+ stops being scanned by the PLC CPU, it applies the data default as outputs. If the GCM+ stops receiving data from one or more devices on the bus, it applies the data default for the missing devices as inputs being passed back to the CPU. The same type of default (last state or zero) is used for both outgoing and incoming data.

If data should hold its last state when communications are lost, select HOLD. If data should be set to 0, select OFF.

Hand-Held Programmer Configuration

R0:05	GC+	<S
DATA DEF:	OFF	

Press the -/+ key to select OFF or HOLD, then press the ENT key.

Report Faults

The GCM+ can send fault reports that can be read by any Series 90-70 PLC on the same bus (the Bus Controller in the Series 90-70 PLC must be rev. 4.0 or later).

If Fault Reports is set to YES, a Drop ID (see below) must be assigned to the Series 90-30 PLC where the GCM+ is located.

If the GCM+ will send fault reports, set **Report Faults** to YES.

Hand-Held Programmer Configuration

```
R0:05 GC+    <S  
REPORT FLTS:NO
```

Use the -/+ key toggles between YES and NO. Press **Entr**. Press the **Right Arrow** key to go to the next item.

Drop ID

A Drop ID must be assigned if a Series 90-70 PLC on the bus will monitor fault report diagnostic messages sent by the GCM+.

The Drop ID (a number from 16 to 254) is used to identify the Series 90-30 PLC where the fault has occurred. This number must not duplicate one used by another PLC that sends Fault Reports, or a Remote I/O Scanner, or a device in the 90-70 system that uses SNP communications.

If two GCM+ modules in the same PLC will both send fault reports, configure the *same* Drop ID for both.

Hand-Held Programmer Configuration

If there is a Series 90-70 PLC that should receive fault reports from the GCM+, enter a Drop ID for the Series 90-30 PLC where the GCM+ module is located.

```
R0:05 GC+    <S  
DROP ID: 33
```

Press **Entr**. Press the **Right Arrow** key to go to the next item.

Global Data References, Lengths, & Offsets

For any device on the bus (including the GCM+ being configured) which corresponds to a bus address *that will send global data*, a **starting reference** and **length** must be configured. An **offset** can also be specified.

Starting Reference

The **starting reference** is the address in the Series 90-30 PLC's %G, %I, %Q, %AI, %AQ, or %R memory when the Global Data will be sent from (for outgoing Global data) or stored (for incoming Global Data).

Length and Offset

For %G, %I, or %Q memory, the length must be specified in bits (points). The number must be a multiple of 8. For the other memories, the length is in registers (2-byte words). The **length** for any bus address that does not send global data should be 0.

For incoming Global Data, you should know the length of the transmission from the external Bus Address. If you want the PLC CPU to receive the entire message, enter this number for the **length**. Enter a shorter **length** to receive only part of the data.

If you want to skip data at the start of the message, you can enter an **offset** in bytes. Using the **length** and **offset**, you can specify any "slice" of the message to be passed to the PLC CPU.

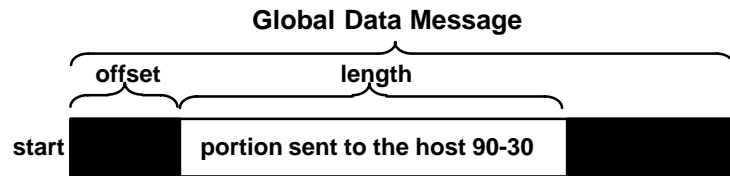

The combined **length** and **offset** must not exceed the total length of the global data message. If they do, the PLC will receive data (always 0) beyond the end of the global data message.

Configuration Software Defaults

The system configuration software provides each bus address with a default starting reference address and length. These defaults, which are listed below, are entirely optional and may be overridden.

SBA	Default Starting Reference	Length (F9)	SBA	Default Starting Reference	Length (F9)	SBA	Default Starting Reference	Length (F9)
24	%G0257	128	3	%AI063	0	14	%Q0449	0
25	%G0385	128	4	%AQ057	0	15	%Q0481	0
26	%G0513	128	5	%AQ059	0	16	%G0001	32
27	%G0641	128	6	%AQ061	0	17	%G0033	32
28	%G0769	128	7	%AQ063	0	18	%G0065	32
29	%G0897	128	8	%I0385	0	19	%G0097	32
30	%G1025	128	9	%I0417	0	20	%G0129	32
31	%G1153	128	10	%I0449	0	21	%G0161	32
0	%AI057	0	11	%I0481	0	22	%G0193	32
1	%AI059	0	12	%Q0385	0	23	%G0225	32
2	%AI061	0	13	%Q0417	0			

Hand-Held Programmer Configuration

Configuration is the same for sending or receiving global data.

There are two screens for every bus address from 0 to 31. Press the **Right Arrow** key to advance from screen to screen. If you want to go back, use the **Left Arrow** key. On the screen that represents the bus address of the GCM+ itself, you will see an asterisk (*) in front of the SBA number. The first of these configuration screens is for bus address 0.

```
R0:05 GC+ SB00<S
IGNORE DEVICE
```

If you want to skip (“ignore”) any bus address, press the **Right Arrow** key.

If the GCM+ will receive global data from the device whose bus address is shown in the upper right corner of the screen, or if the GCM+ module’s own bus address is being displayed, enter the memory type (I, Q, G, AI, AQ, or R) where the data will be located in the Series 90-30 PLC. Press the **ENT** key. Example:

```
R0:05 GC+ SB04>S
I _
```

Press the $\frac{I}{A_i}$ key once. Enter the number of bits or registers of the global data to be written or read. For %G, %I, or %Q memory, the number must be a multiple of 8. If it isn’t, the HHP will automatically adjust it. Press **ENT**.

```
R0:05 GC+ SB04>S
I0040:I_
```

Enter the beginning reference for the data and press **ENT**. The HHP displays references that correspond to the starting reference and length you have entered. For example, for a starting reference of 33 and length of 40, the HHP would show:

```
R0:05 GC+ SB04>S
I0040:I0033-0072
```

Press the **Right Arrow** key to display the second configuration screen for the same bus address. For example:

```
R0:05 GC+ SB04>S
MSG OFFS: 0
```

If the current configuration screen is for the GCM+ module itself, skip to the next bus address, or exit if you have finished configuring devices.

If the configuration is for a device that will send data to the GCM+, and if the GCM+ should read only part of a global data message, but not the beginning, enter an **offset**, then press the **Enter** key. The offset is the amount, in bytes, to be skipped at the start of the message.

Use the **Right Arrow** key to continue configuring global data parameters. Skip the bus addresses that don’t correspond to global data devices. It isn’t necessary to go through all 32 bus devices; when you finish configuring devices, you can exit.

Configuration Example 1

GCM+ modules in two Series 90-30 PLCs exchange global data with each other. One of them also exchanges global data with another Series 90-30 PLC that has an older Genius Communications (GCM) Module (IC693CMM301) instead of a GCM+. If there is a GCM on the bus, the following restrictions exist:

1. Any device that communicates with a GCM must use an SBA from 16 to 23.
2. Any device that communicates with a GCM is constrained to send an amount of data the GCM can handle. GCM modules can send and/or receive up to a total of 32 bytes (256 bits) of global data.
3. As a result, devices that send large amounts of global data should not communicate with a GCM and so should not use an SBA from 16 to 23 when on a bus which contains a GCM.

In this example:

- The GCM+ that does not exchange global data with the GCM uses SBA #1. Every bus scan, this GCM+ sends 48 bytes of global data from %R memory. The data is received by the GCM+ at SBA #20, which is configured to place the data into %R memory. The GCM module in the third PLC is not capable of receiving the data from SBA #1.

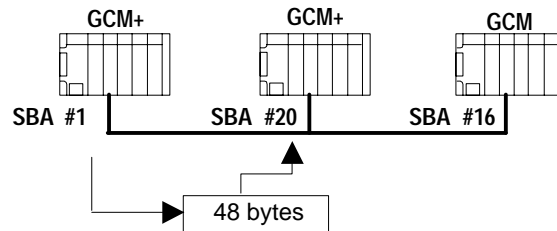

- The second GCM+ sends 16 bytes of global data from %G memory. To allow its data to be received by the GCM module, the second GCM+ is assigned SBA #20. The GCM+ module at SBA #1 places the data into %I memory. The GCM module uses %G memory for all global data.

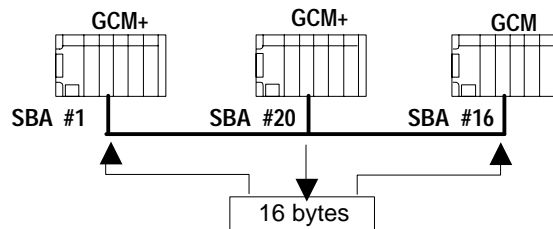

- The GCM module, which uses SBA #16, sends 16 bytes of global data from %G memory. Both of the GCM+ modules receive the data and place it in %I memory.

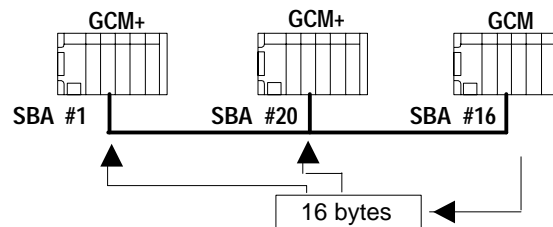

Configuration Summary for this Example

Device	SBA	Transmit: Refs/Bytes	Received from #1: Refs/Bytes	Received from #16: Refs/Bytes	Received from #20: Refs/Bytes
GCM+	1	%R0001/48	none	%I0001/16	%I00017/16
GCM+	20	%G0001/16	%R0001/48	%I0001/16	none
90-30 GCM	16	%G001/16	none	none	%G129/16

Configuration for GCM+ #1

1. Configure the first GCM+ at SBA #1.
2. Configure the baud rate so that all devices operate at the same rate.
3. Configure the references, lengths and offsets for global data.
 - A. On the configuration screen, there is an asterisk (*) beside SBA #1, because it is the device being configured. Enter the parameters for the data to be transmitted:

StartingReference	%R0001
ReferenceLength	24 registers (=48 bytes)
MsgBufferByteOffset	0
 - B. Enter the parameters for the data to be received from GCM+ #20:

StartingReference	%I0001
ReferenceLength	128 bits (==16 bytes)
MsgBufferByteOffset	0
 - C. Enter the parameters for the data to be received from the GCM at SBA #16:

StartingReference	%I0017
ReferenceLength	128 bits (16 bytes)
MsgBufferByteOffset	0
 - D. For all other SBAs on the bus:

StartingReference	don't care
ReferenceLength	0(required)
MsgBufferByteOffset	0

Configuration for GCM+ #20

1. Configure the second GCM+ at SBA #20.
2. Configure the baud rate so that all devices operate at the same rate.
3. Configure the references, lengths and offsets for global data.
 - A. On the configuration screen, there is an asterisk (*) beside SBA #20, because it is the device being configured. Enter the parameters for the data to be transmitted:

StartingReference	%G0001
ReferenceLength	128 bits (=16 bytes)
MsgBufferByteOffset	0
 - B. Enter the parameters for the data to be received from GCM+ #1:

StartingReference	%R0001
ReferenceLength	24 registers (=48 bytes)
MsgBufferByteOffset	0
 - C. Enter the parameters for the data to be received from the GCM at SBA #16:

StartingReference	%I0017
ReferenceLength	128 bits (=8 x 16 bytes)
MsgBufferByteOffset	0
 - D. For all other SBAs on the bus:

StartingReference	don't care
ReferenceLength	0(required)
MsgBufferByteOffset	0

Configuration for GCM #16

Please see the *Genius Communications Module User's Manual* (GFK-0412) if you need more information about how the GCM is configured, and how it handles global data.

Configuration Example 2

There are two Series 90-30 PLCs with GCM+ modules on a bus with a Series 90-70 PLC and a host computer.

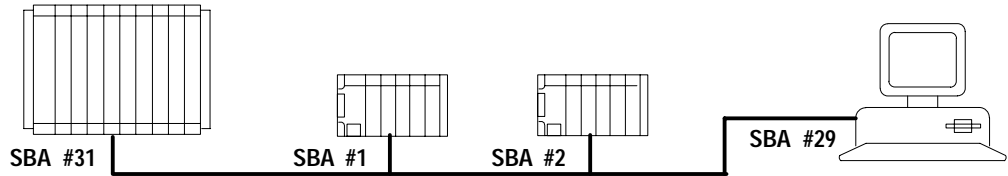

- Both Series 90-30 PLCs send 50 bytes of global data.
- Each Series 90-30 PLC listens to 10 bytes of the other's global data and places the data into its own %G memory.

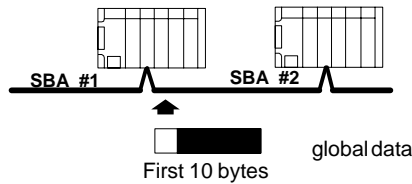

- The Series 90-70 PLC receives all Global Data from both Series 90-30s. Both sets of incoming global data are placed into %I memory.

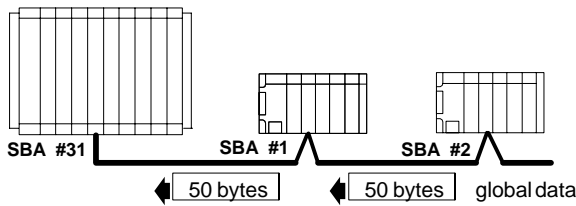

- The Series 90-70 PLC broadcasts 100 bytes of global data each bus scan. The first 60 bytes is for one Series 90-30 PLC and the last 40 bytes is for the other.

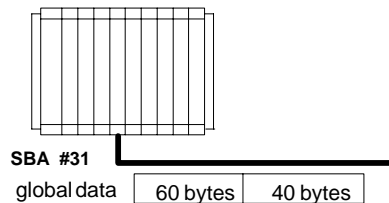

- Each Series 90-30 PLC reads only the intended portion of the data sent by the 90-70, and discards the rest by using the **offset** and **length** parameters.

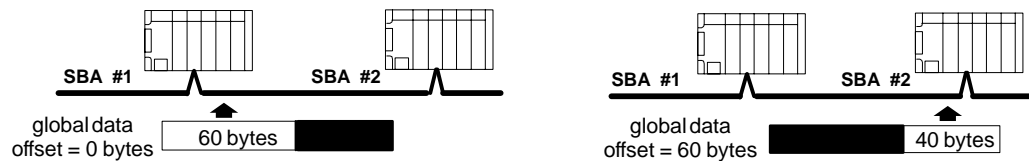

- The computer acts as a monitor, and reads all global data from the Series 90-30 and Series 90-70 PLCs, and transmits no global data itself.

Configuration Summary for this Example

Device	SBA	Transmit: Refs/Bytes	Received from #1: Refs/Bytes	Received from #2: Refs/Bytes	Received from #31: Refs/Bytes
GCM+	1	%I0001/50	none	%G0001/10	%Q0001/60
GCM+	2	%I0001/50	%G0001/10	none	%Q0001/40
90-70 GBC	31	%Q0001/100	%I1001/50	%I2001/50	none
PCIM	29	none	all	all	all

Configuration for GCM+ #1

1. Configure the first GCM+ at SBA #1.
2. Configure the baud rate so that all devices operate at the same rate.
3. Configure the references, lengths and offsets for global data.
 - A. On the configuration screen, there is an asterisk (*) beside SBA #1, because it is the device being configured. Enter the parameters for the data to be transmitted:

StartingReference	%I0001
ReferenceLength	400 bits (=50 bytes)
MsgBufferByteOffset	0
 - B. Enter the parameters for the data to be received from GCM+ #2:

StartingReference	%G0001
ReferenceLength	80 bits (=10 bytes)
MsgBufferByteOffset	0 (the first 10 bytes will be received)
 - C. Enter the parameters for the data to be received from the Series 90-70 PLC's Bus Controller, at SBA #31:

StartingReference	%Q0001
ReferenceLength	480 bits (=60 bytes)
MsgBufferByteOffset	0 (the first 60 bytes will be received)
 - D. For all other SBAs on the bus:

StartingReference	don't care
ReferenceLength	0 (required)
MsgBufferByteOffset	0

Configuration for GCM+ #2

1. Configure the second GCM+ at SBA #2.
2. Configure the baud rate so that all devices operate at the same rate.
3. Configure the references, lengths and offsets for global data.
 - A. Enter the parameters for the data to be received from GCM+ #1:

StartingReference	%G0001
ReferenceLength	80 bits (=10 bytes)
MsgBufferByteOffset	0 (the first 10 bytes will be received)
 - B. On the configuration screen, there is an asterisk (*) beside SBA #2, because it is the device being configured. Enter the parameters for the data to be transmitted:

StartingReference	%I0001
ReferenceLength	400 bits (=50 bytes)
MsgBufferByteOffset	0
 - C. Enter the global data reference, length, and offset for the data to be received from the Series 90-70 PLC's Bus Controller, at SBA #31:

StartingReference	%Q0001
ReferenceLength	320 bits (=40 bytes)
MsgBufferByteOffset	60 (the first 60 bytes will be skipped)
 - D. For all other SBAs on the bus:

StartingReference	don't care
ReferenceLength	0 (required)
MsgBufferByteOffset	0

Configuration for the Other Devices

The PCIM at SBA #29 is set up to handle the three global data messages via its application program. The Series 90-70 PLC at SBA #31 configures GCM+ modules at SBAs #1 and #2, and expects each to send 50 bytes, which it places in 90-70 memory at %I1001-%I1401 and %I2001-%I2401 respectively.

Configuration Example 3

In this example, there are four Series 90-30 PLCs. Each one sends global data from %Q memory. Each of the other Series 90-30s reads 8 bytes of the global data and places it into %I memory.

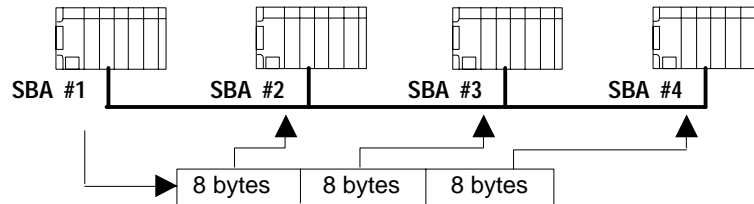

This illustration represents the global data transmission for one Series 90-30 PLC. In the same bus scan, the three other PLCs also send global data the same way.

In this system:

- A GCM+ is installed in each Series 90-30 PLC. The GCM+ modules are configured to use Bus Addresses (SBAs) 1 through 4.
- In each Series 90-30 PLC, the first 32 bytes (256 bits) of %I and %Q memory is set aside for global data. The 32 bytes are divided into 4 segments of 8 bytes each; the segments are organized in ascending order of SBAs.

%Q Memory	%I Memory
SBA #1	SBA #1
SBA #2	SBA #2
SBA #3	SBA #3
SBA #4	SBA #4

Thus, each PLC has a segment of its %Q memory set up to convey data to another specific PLC, and a corresponding segment set up in %I to receive data. There is an unused segment in each table, which corresponds to the SBA of that GCM+.

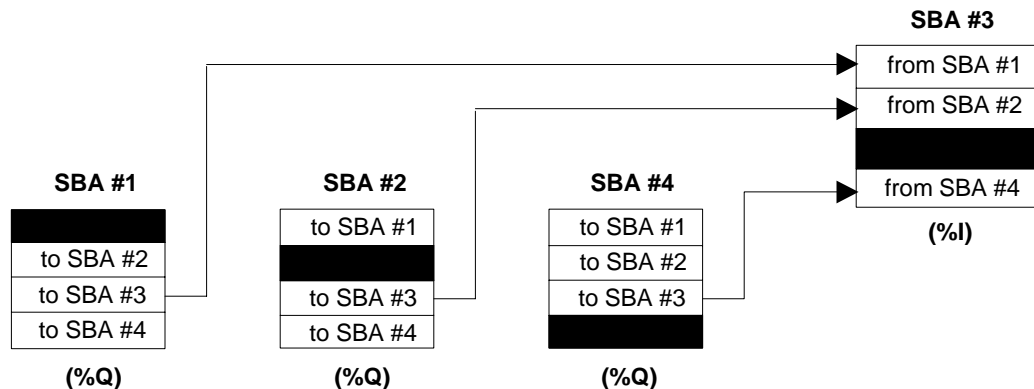

Configuration Summary for this Example

Configuration for each of the four GCM+ modules in the example system is listed below, along with a representation of what happens when that GCM+ sends global data. Each GCM+ is set up to transmit 32 bytes of %Q data (8 bytes for each other GCM+ and 8 “unused” bytes). Each GCM+ is also configured to receive 8 bytes from each of the other GCM+ modules. Each GCM+ uses the same Message Byte Offset for each global data message it receives. The offset corresponds to its place in the SBA sequence. Other configuration for each GCM+ includes setting **status** to %I1025.

SBA #1 Sends Global Data

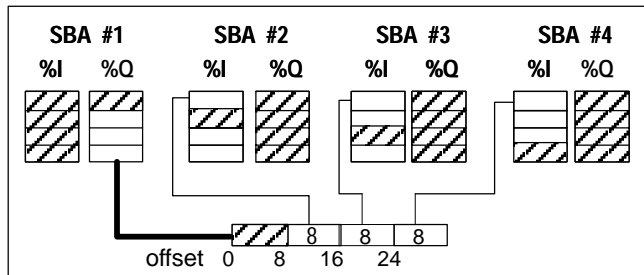

Configuration For SBA #1

SBA	Starting Reference	Reference Length (bits)	Message Buffer Offset (bytes)
SBA #1	%Q0001	256	x
SBA #2	%I0065	64	0
SBA #3	%I0129	64	0
SBA #4	%I0193	64	0
all others	x	0	x

SBA #2 Sends Global Data

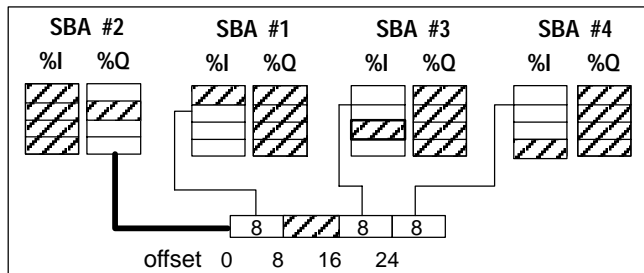

Configuration For SBA #2

SBA	Starting Reference	Reference Length (bits)	Message Buffer Offset (bytes)
SBA #1	%I0001	64	8
SBA #2	%Q0001	256	x
SBA #3	%I0129	64	8
SBA #4	%I0193	64	8
all others	x	0	x

SBA #3 Sends Global Data

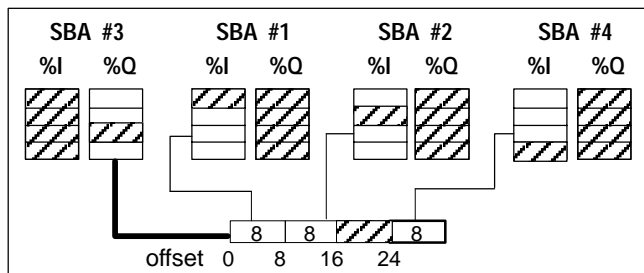

Configuration For SBA #3

SBA	Starting Reference	Reference Length (bits)	Message Buffer Offset (bytes)
SBA #1	%I0001	64	16
SBA #2	%I0065	64	16
SBA #3	%Q0001	256	x
SBA #4	%I0193	64	16
all others	x	0	x

SBA #4 Sends Global Data

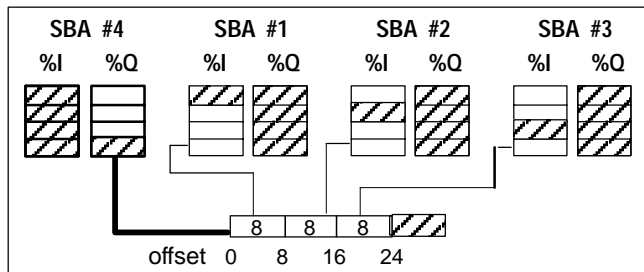

Configuration For SBA #4

SBA	Starting Reference	Reference Length (bits)	Message Buffer Offset (bytes)
SBA #1	%I0001	64	24
SBA #2	%I0065	64	24
SBA #3	%I0129	64	24
SBA #4	%Q0001	256	x
all others	x	0	x

Configuration Example 4

Global Data can be used to emulate a remote I/O option for Series 90-30 PLCs. In this type of system, one device controls the I/O of one or more Series 90-30 PLCs. While the controller shown in this example is a Series 90-30 PLC, a Series 90-70 PLC or other type of host could also serve this function.

In the previous example, each PLC sent global data from its output table to the **input** tables of all the others. In this example, one PLC sends 24 bytes of global data from its output table to the **output** tables of the others, so it can actually control the output devices of three Series 90-30 PLCs. Each 90-30 PLC uses 8 bytes of the output data.

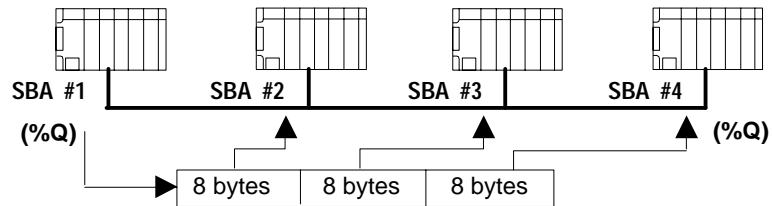

Each Series 90-30 PLC sends global data from its own input table to the first PLC's input table, so the application program in the first PLC can act on inputs from the "remote" 90-30s as though they were inputs from its own PLC system.

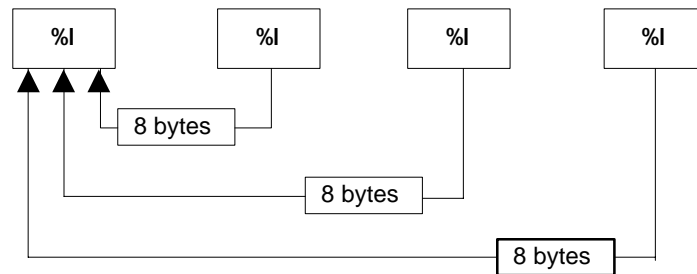

The Series 90-30 PLCs that act as remote I/O devices do not need to contain an application program to use the %I and %Q data. The data is exchanged directly with input and output modules that are assigned to these same %I and %Q references.

When configuring GCM+ modules in PLCs that will have no application program, the **data default** parameter should be configured to be OFF. That will ensure that disruptions (caused by loss of PLCs or loss of communications) results in a predictable, "safe" shutdown. If the data default parameter were set to hold last state instead, some outputs would remain ON until the disruption was resolved.

In this system:

- A GCM+ is installed in each Series 90-30 PLC. The GCM+ modules are configured to use Bus Addresses (SBAs) 1 through 4.
- The GCM+ in the Series 90-30 PLC that will control the other PLCs' inputs and outputs is assigned SBA #1. The GCM+ modules in the "remote" PLCs are assigned #2, 3, and 4.
- In the Series 90-30 PLC that will be the controller, the first 24 bytes (192 bits) of %I and %Q memory is set aside for global data. The 24 bytes are divided into 3 segments of 8 bytes each; the segments are organized in ascending order of SBAs.

%Q Memory	%I Memory
SBA #2	SBA #2
SBA #3	SBA #3
SBA #4	SBA #4

- In each Series 90-30 PLC that will serve the "remoteI/O" function, the GCM+ is configured to receive from the controller the portion of the %Q table that is assigned to it.

During operation, the following occurs each bus scan:

- A. The GCM+ module in the controller PLC broadcasts 24 bytes of global data beginning at %Q0001 to all other devices on the bus.
- B. Every "remoteI/O" GCM+ receives 24 bytes of global data from the controller, but passes only the 8-byte segment that starts at its configured Message Buffer Byte Offset to the PLC CPU.
- C. Each remote PLC broadcasts 8 bytes of global data from %I0001 to all other devices on the bus.
- D. The GCM+ in the controller receives the three broadcasts and places all the data in contiguous 64-bit blocks at %I0001 - %I0193.
- E. Each remote GCM+ also receives the broadcasts from the other two remote PLCs. Because the length parameter for these SBAs is 0, the GCM+ modules in the remote PLCs discard each others' messages.

Configuration Summary

Global data configuration for each of the four GCM+ modules in the example system is shown below. Other configuration for each GCM+ includes setting **status** to %I1025. The **baud rate** and **S6 ref** selections remain defaulted.

For SBA #1

Global output data sent by SBA #1 (controller)



SBA	Starting Reference	Reference Length(bits)	MessageBuffer ByteOffset
SBA #1*	%Q0001	192	x
SBA #2	%I0001	64	0
SBA #3	%I0065	64	0
SBA #4	%I0129	64	0
all others	x	0	x

Offset 0 for other SBA#s on bus

For SBA #2

inputs sent by SBA #2 as global data



SBA	Starting Reference	Reference Length(bits)	MessageBuffer ByteOffset
SBA #1	%Q0001	64	0
SBA #2*	%I0001	64	x
all others	x	0	x

Offset 0 for controller SBA #1

For SBA #3

inputs sent by SBA #3 as global data



SBA	Starting Reference	Reference Length(bits)	MessageBuffer ByteOffset
SBA #1	%Q0001	64	8
SBA #3*	%I0001	64	x
all others	x	0	x

Offset 8 for controller SBA #1

For SBA #4

inputs sent by SBA #4 as global data



SBA	Starting Reference	Reference Length(bits)	MessageBuffer ByteOffset
SBA #1	%Q0001	64	16
SBA #4*	%I0001	64	x
all others	x	0	x

Offset 16 for controller SBA #1

For this example, the only part of the GCM+ configuration that changes in the remote PLCs is the **offset**; it increments by eight as the Bus Address of the GCM+ increments.

Configuration Example 5

A Series 90-70 PLC exchanges I/O data with two Series 90-30 PLCs.

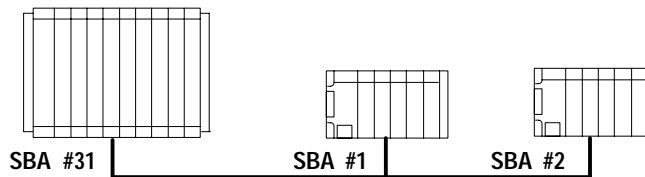

- During the input portion of each Series 90-30 PLC's sweep, input data from I/O modules is placed into the same references used for sending global data.



- When each GCM+ module has its turn on the bus, it transmits the input as Global Data, which is read by the Series 90-70 PLC.

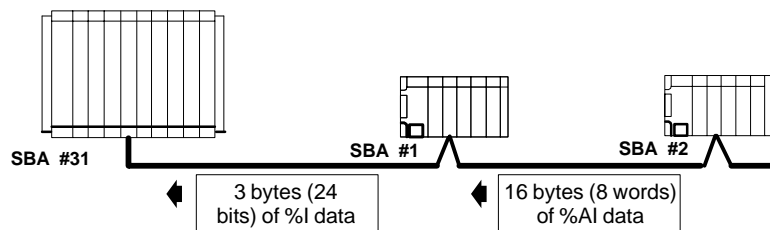

- The application program in the Series 90-70 PLC processes the input data. It provides 100 bytes of outputs to be sent to the Series 90-30s as global data. Within the 100-byte global data message, the first 60 bytes is discrete output data for one Series 90-30 PLC and the last 40 bytes is analog output data for the other.

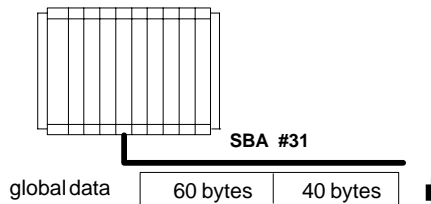

- Each Series 90-30 PLC reads only the intended portion of the data sent by the 90-70, and discards the rest by using the **offset** and **length** parameters. The first GCM+ places its portion of the data into %Q memory in its Series 90-30 PLC. The second GCM+ places its portion of the data into %AQ memory.

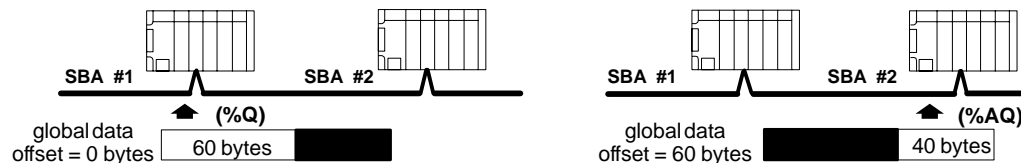

- During the output portion of each PLC's sweep, the received output data is sent to output modules that are configured to use the same %Q and %AQ references as the global data. Because the Series 90-70 acts as the controller for the 90-30 I/O modules, 90-30 application programming is not needed.

Configuration Summary for this Example

Device	SBA	Transmit: Refs/Bytes	Received from #1: Refs/Bytes	Received from #2: Refs/Bytes	Received from #31: Refs/Bytes
GCM+	1	%I0001/3	none	none	%Q0001/60
GCM+	2	%AI0001/16	none	none	%AQ0001/40
90-70 GBC	31	%G0001/100	%I1001/3	%AI0001/16	none

Configuration for GCM+ #1

1. Configure the first GCM+ at SBA #1.
2. Configure the baud rate so that all devices operate at the same rate.
3. Configure the references, lengths and offsets for global data.
 - A. On the configuration screen, there is an asterisk (*) beside SBA #1, because it is the device being configured. Enter the parameters for the data to be transmitted:

StartingReference	%I0001
ReferenceLength	24 bits (=3 bytes)
MsgBufferByteOffset	0

- B. Enter the parameters for the data to be received from the Series 90-70 PLC's Bus Controller, at SBA #31:

StartingReference	%Q0001
ReferenceLength	480 bits (=60 bytes)
MsgBufferByteOffset	0 (the first 60 bytes will be received)

- C. For all other SBAs on the bus:

StartingReference	don't care
ReferenceLength	0 (required)
MsgBufferByteOffset	0

Configuration for GCM+ #2

1. Configure the second GCM+ at SBA #2.
2. Configure the baud rate so that all devices operate at the same rate.
3. Configure the references, lengths and offsets for global data.
 - A. On the configuration screen, there is an asterisk (*) beside SBA #2, because it is the device being configured. Enter the parameters for the data to be transmitted:

StartingReference	%AI0001
ReferenceLength	8 words (=16 bytes)
MsgBufferByteOffset	0

- B. Enter the global data reference, length, and offset for the data to be received from the Series 90-70 PLC's Bus Controller, at SBA #31:

StartingReference	%Q0001
ReferenceLength	320 bits (=40 bytes)
MsgBufferByteOffset	60 (the first 60 bytes will be skipped)

- C. For all other SBAs on the bus:

StartingReference	don't care
ReferenceLength	0 (required)
MsgBufferByteOffset	0

Configuration for the Other Devices

The Series 90-70 PLC at SBA #31 configures GCM+ modules via the system configuration software at SBAs #1 and #2. It assigns 24 bits (=8 bytes) of %I memory to the input data from the first GCM+, and 8 words (=16 bytes) of %AI memory to the input data from the second GCM+.

Chapter 5

Diagnostics

This chapter describes the diagnostics features of the Enhanced Genius Communications Module:

- Status bits that reflect the presence or absence of other devices on the bus, and confirm the operating status of the GCM+ itself.
- Diagnostic messages that report the operating status of the Series 90–30 PLC and its modules to a Series 90–70 PLC on the same bus.

The diagnostic features of the GCM+ must be configured. See chapter 4 for more information about configuration.

Status Bits

The GCM+ uses 32 reference address bits in %I memory to supply status information for the PLC. A default beginning reference (the next available %I) for the status bits is automatically supplied by the system configuration software or by a Hand-held Programmer, but a different %I reference can be selected. Status bits are organized in ascending order of the devices' Bus Addresses (SBAs), beginning at the first %I status reference.

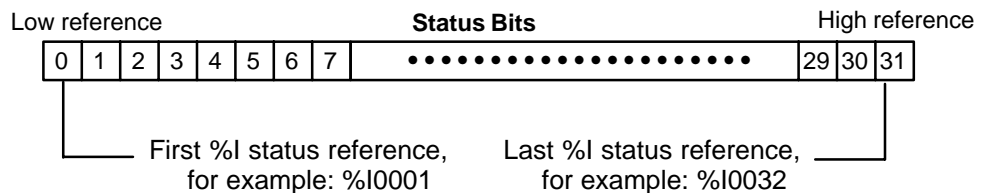

Monitoring GCM+ and Bus Device Status

Every bus scan, the Series 90–30 PLC reads the status bits from the GCM+. Your application program logic may monitor the selected %I memory area regularly to check on the operating status of the GCM+ and the devices on its bus. This is especially recommended if the data default parameter has been set to hold last state.

- The status bits for devices other than the GCM+ itself indicate whether they are currently on the bus (status = 1). If the status bit for a device is 0, any global data received from that Bus Address should be discarded. If the data default parameter has been set to OFF, this data will be 0.
- During normal operation, the status bit for the GCM+ is 1 if the GCM+ is on the bus and 0 if it isn't.

Fault Reports

If the Fault Reports capability of the GCM+ is enabled by configuration, the GCM+ will send diagnostic messages that can be read by a Series 90–70 PLC on the same bus. The Bus Controller in the Series 90–70 PLC must be rev. 4.0 or later.

These messages will report:

- I/O faults like addition or loss of a module or of another rack (see below) within the Series 90–30 PLC.
- Series 90–30 board-specific faults.

If a fault occurs, the GCM+ sends one Series 90 fault datagram. Even if the fault still exists, the GCM+ does not repeat the fault report. For example, for a Loss of Module fault, a module must be added back at the same rack and slot location before another Loss of Module fault can be reported.

Both the GCM+ and its PLC CPU must be operating for the Series 90–30 to send Series 90 fault datagrams. So these diagnostics will *not* report loss or addition of the GCM+, the CPU module, or their rack(s).

At powerup, the GCM+ cannot report faults that occur before it receives its configuration from the PLC. To avoid missing any faults, the GCM+ should be installed right next to the CPU module. In that way, the GCM+ will receive its configuration before the rest of the modules in the system are logged in.

Fault Clearing

Faults are cleared in the normal way, from the programming software or using a Hand-held Programmer.

Clearing a fault in the Series 90–30 PLC does not remove it from the fault table in the Series 90–70 PLC. That fault message can be cleared using the programming software. No 90–70 fault contacts are associated with the fault.

Drop ID

Part of the Series 90–70 fault display is the Drop ID (a number between 16 and 254). The Drop ID is intended to uniquely identify a remote drop, so each 90–30 should use a different Drop ID. If there are two GCM+ modules installed in one Series 90–30 PLC, they should use the same Drop ID, so the 90–30 gets reported in the same way via either GCM+. The Series 90–70 Remote I/O Scanner also uses the Drop ID, so assignments should take this into account.

Note that unlike the Remote I/O Scanner, the GCM+ does not use the Drop ID as part of its SNP ID; there is no SNP association in the GCM+.

This appendix describes the characteristics of the bus cable that links Genius devices.

- Electrical Interface
- Serial Bus Waveforms
- Effect of Long Cables, Repeaters, or Unspecified Cable Types on Bus Length
- Serial Data Format
- Bus Access
- Bus Errors Caused by Noise

This information supercedes the equivalent text portion of chapter 2 of the *The Genius I/O System and Communications Manual* (GFK-90486), "The Communications Bus".

A Genius serial bus consists of two or more Genius devices, and (usually) the bus cable that connects them. A single block or bus controller with a Hand-held Monitor directly attached, properly terminated with a 75Ω resistor, are considered the smallest possible Genius communications bus.

Electrical Interface

The Genius serial bus uses computer grade twisted pair data cable. The half duplex token sequence used requires only a single pair since at any time only one station is transmitting and all others are receiving. All stations must receive in order to track the present token value and take their appropriate turn on the bus, regardless whether the data is to be used locally. The transmit sequence is the same as the serial bus address (SBA) set into each location during configuration. A simplified interface circuit is shown below:

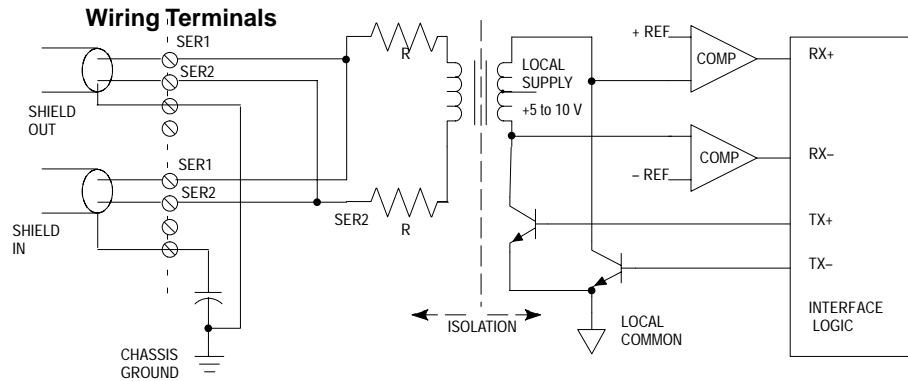

Signal coupling to the bus is via a high frequency, high isolation pulse transformer. This permits the bus and the local logic to be at different voltage levels. The pulse waveforms are bipolar (see next section below) to reduce DC baseline offsets in the waveform.

The daisy-chained bus is shown on the left in the above illustration. The SER 1 and SER 2 lines are merely tapped at the intermediate locations along the bus. These connections must be consistent since the signal is polarized. The shield of the cable is broken into segments at each location. Each shield segment is DC grounded at one end (SHIELD OUT), and terminated with a small capacitor at the other (SHIELD IN). The segmenting breaks up long ground loop paths. The capacitor termination reduces common mode noise from high frequency pickup, while preventing large ground loop currents in the shield at low frequencies.

The alternately switching transistors produce a negative pulse followed by a positive pulse across **SERIAL 1** relative to **SERIAL 2**. The bit waveform is a series of these pulses, as will be shown later. The transformer provides isolation (2500 volts test) between the bus and the local logic, permitting these to be at different voltages. The internal resistors in each line provide current limit and some termination function during transmission.

The balanced (differential) signals on the twisted pair provide high noise immunity due to the magnetic (H field) cancellation effect of the twisting, as well as electric (E field) reduction by the shielding. Most remaining noise pickup is common mode: the transformer provides a high common mode noise rejection by looking only at the differential signal across the SER 1-2 lines. The two input comparators detect the positive polarity input pulses separately from the negative; these are sent to a custom interface logic chip which digitally filters these for timing and sequence, then reconstructs the NRZ digital data. Voltages between the two thresholds are ignored. This filtering, and the high input threshold of the comparators, are highly effective in rejecting both random impulse noise and low level line reflections. Finally a CRC-6 checksum check is performed before the data is sent to the local processor (not shown).

Genius Transceiver Electrical Specification

Property	Min	Max
Normal peak voltage V_p into 78 ohm terminated cable (1)	3.5 volts	5.5 volts
Normal peak voltage V_p into 150 ohm terminated cable (1)	6.0 volts	9.5 volts
Rated bus impedance (2)	78 ohms	150 ohms
Maximum output voltage (SER 1 and 2 open) (3)	Peak RMS	35 volts 15 volts
Maximum output current (SER 1 and 2 shorted together) Peak RMS		180 milliamp 50 milliamp
Transmitter source resistance	80 ohms	140 ohms
Transmitter source inductance (transformer leakage inductance)		10 microhenries
Receiver input threshold; $+V_r$, $-V_r$ (4)	0.7 volt	1.1 volt
Receive mode input impedance	10 K ohm	
Receive mode load inductance (transformer shunt inductance)	6 millihenries	12 millihenries
Receiver common mode rejection (DC to 1 MHz)	60 dB	
Shield capacitor termination	0.1 microfarad	
Isolation, serial bus to circuit, continuous	240 volts AC	

Notes:

- (1) V_p may vary among various module types.
- (2) Rated load is half cable impedance when termination is included.
- (3) Peak open circuit voltage contains underdamped ringing due to lack of termination.
- (4) Input voltages between $+V_r$ and $-V_r$ thresholds are ignored.

Serial Bus Waveforms

The actual waveforms seen on the cable depend on the cable impedance and the distance from the station presently transmitting. A data "0" is a series of three AC pulses, while a "1" is no pulse.

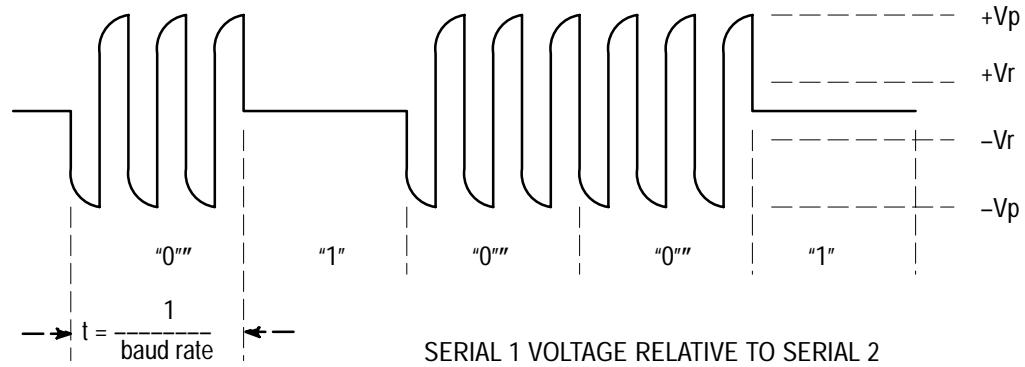

Use caution when connecting instrumentation to the bus. A differential probe or a summation of two probes relative to ground is required. Inadvertent grounding of one side of the bus can cause loss of data or data errors.

The pulse frequency is three times the baud frequency, for example 460.8 KHz at 153.6 Kb.

The peak transmitted voltage V_p and the receiver thresholds V_r are per the electrical specification above. The peak voltages measured will decline with distance along the cable from the transmitting station, so different stations will have varying amplitudes. The wave shape will also become more rounded with distance.

The minimum amplitude pulses seen during a "0" should exceed the receiver threshold V_r of 900 millivolts by 50% (about 1.4 volts) for best reliability. An occasional pulse at or below the threshold may still not cause the bit to be missed, due to a voting algorithm in the logic, however.

Likewise, no pulses greater than V_r should exist during logic "1" intervals. Occasional extra pulses during this interval are also rejected by the logic.

Line reflections will show up as notch distortion during the pulse or low level pulses during "1" intervals, and their appearance is synchronized to the baud frequency. These cause no problem if they do not cause violation of the amplitude criteria of the previous paragraphs.

The Serial 1 and Serial 2 lines should always have a termination resistor equal to the characteristic impedance of the cable connected at each extreme end. When testing a Genius block or other device using a Hand Held Monitor, when no serial bus is present, a terminating resistor will improve integrity. 75 Ohms is recommended.

Effect of Long Cables, Repeaters, or Unspecified Cable Types on Maximum Length Bus

Three effects limit the maximum length bus available at any baud rate:

1. Voltage attenuation
2. Waveform distortion (frequency dispersion)
3. Propagation delays

Attenuation

The transmitter output levels and receiver thresholds determine the maximum attenuation that can be tolerated. For Genius products, this is the principal determinant when using recommended cable types.

Distortion

Waveform distortion is due to the limited bandwidth of wire media, which causes the various frequency components of a pulse waveform to travel at different speeds and thus arrive separately in time (called dispersion). As a result, the received pulse appears rounded and distorted. The signal at the extreme end from the transmitter may look rounded and skewed as shown below. Distortion is most apparent near the beginning and end of a pulse train where it may appear as a change in phase or a frequency shift. Critical timing for a logic 0 transmission is shown below in a more detailed version of the waveform:

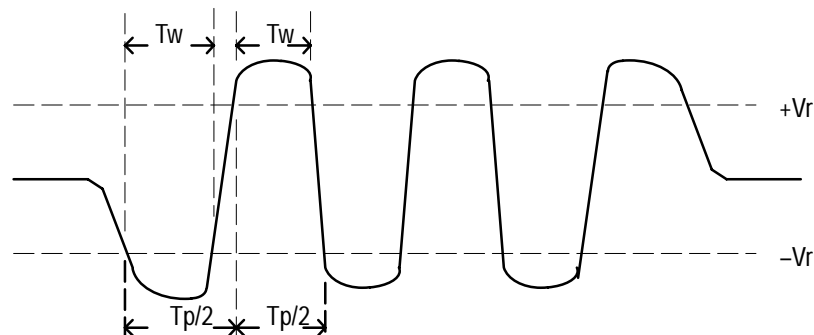

Note the first and last half-cycle look wider. The most critical to operation is the first full cycle of the first start bit of the transmission. Detection of this pulse establishes the time synchronization of the receiver to the incoming waveform. Missing this first pulse does not cause the data to be missed, but may compromise the noise immunity with respect to extra or missing pulses. The frequency of the AC pulse is 3X the baud rate as noted earlier. This means the normal period $T_p(\text{normal})$ is:

- 2.17 microseconds at 153.6 Kb
- 4.34 microseconds at 76.8 Kb
- 8.68 microseconds at 38.4 Kb.

The half cycle pulse width, when measured between the positive and negative receiver thresholds, denoted as $T_p/2$ in the figure, will vary along the waveform due to dispersion, and resembles a frequency shift. The digital input filter essentially is a band pass filter which looks at the half cycle timing $T_p/2$, and the duration above the thresholds, T_w . The limits are:

- $T_p/2 = 0.6 T_p(\text{normal})$ maximum
- $T_w = 0.188 T_p(\text{normal})$ minimum

These measurements can be taken when evaluating the maximum length of an unspecified cable. Dispersion is much less of a problem with fiber optic links since the media is much wider bandwidth, and therefore has less distortion.

Propagation Delay

The propagation delay is caused by travel time of the signal down the cable. Typical signal velocity in data grade cables is around 65– 78% of the speed of light. This requires about 3 microseconds to travel a 2000 foot long bus. This is about half a bit time at 153,6 Kb. This skew could affect the bus access sequence since only one bit of quiet bus (skip) time is usually allocated between transmission of adjacent addresses. (Refer to Bus Access Time section below.) The signal must reach all devices on the bus within the period of one bit. Propagation delay causes the ultimate limitation in bus length, even with ideal media. Propagation speed through fiber optic is not significantly different than wire, and delays through the interfaces must be accounted for.

Serial Data Format

The Genius protocol is designed to produce maximum throughput of data by using a minimum overhead of control and synchronizing characters.

Each character is 11 bits long, comprising a start bit (always 0), next a control bit, followed by 8 bits of data, sent LSB first. The last bit is a stop bit, always 1. Successive characters are sent with no time space between them. The control bit is used to signal the type of character being sent. A 1 indicates a control character, and 0 a data character.

A minimum transmission is comprised of a start character, one or more data characters, and a stop character. The Start character data contains the address and whether the transmission is directed to a specific address or a broadcast to all. The End character contains the CRC– 6 checksum. More complex transmissions may have additional start and end of block characters to break up the message into “blocks” of data (not to be confused with Genius I/O “Blocks”). For example, a Bus Controller can send device specific messages (blocks of data) to all devices on the bus during one transmission cycle.

Bus Access

All devices must receive the current SBA and the stop character even though the data is irrelevant locally. After the stop control character is received, each device on the bus starts a timer. The time delay is equal to a “skip time”, times the difference between the device Serial Bus Address (SBA) and the last SBA received. The device will transmit after the time delay if no other start bits are detected first. Thus each device takes turn in order of SBA. Unused SBAs result in longer times between messages. All devices must detect messages within this skip time delay. A bus “collision” (two sources transmitting simultaneously) results if this sequence is missed. The skip time value is equal to one bit period, except on the 153.6e rate, where it is two bit periods long. The longer interval is useful to accommodate the longer propagation delays due to longer bus cables, or when delays are introduced by fiber optic or other repeaters, The worse case is when adjacent SBAs are physically located at opposite ends of a long bus. For example, assume SBA 4 and 6 are at one end of a 2000 foot bus and SBA5 at the other, operating at 153.6s Kb. When SBA 4 end character is detected, SBA6 immediately starts timing 2 skip times (13 uSec) to start of it’s transmission. SBA5 receives the end character 3 uSec later, and starts timing 1 skip time (6.5 uSec). Thus SBA 5 will start transmitting 9.5 uSec after SBA 4 quit. This allows 3.5 uSec for the signal to get back to SBA6 to cancel it’s transmission turn. The 3 uSec transmission delay leaves only 0.5 uSec to do this and avoid a collision between SBA5 and 6.

Bus collisions result in missing data or detected CRC errors. Problems resulting from bus collisions can be fixed by not using (skipping) a SBA, resequencing SBAs in order along the bus, going from 153.6s baud to the 153.6e, or a lower baud rate.

Bus Errors Caused by Noise

Most capacitively- and magnetically-coupled noise shows up as common mode voltage on the bus. The bus provides a 60 dB common mode rejection ratio. A noise spike above 1000 volts would be required to corrupt the data. The bus receivers filter out corrupted data and perform a 6-bit cyclic redundancy check to reject bad data. Corrupted signals due to noise show up as missed data rather than incorrect data. The bus continues operating to the maximum extent possible when bus errors are detected; random bus errors do not shut down communications. Bad data is rejected by the receiving device and excessive errors are reported to the controller. Bus errors are indicated by flickering of I/O block and bus controller LEDs. If excessive bus errors occur, the problem should be found and corrected.

Appendix B

Comparison of the GCM+ and the GCM

The Genius Communications Module (GCM) is an earlier, less powerful version of the GCM+. Both types of module can be used on the same bus, but they cannot be installed in the same PLC. The two types of module can exchange global data with each other.

Differences between the GCM+ and GCM are summarized below.

	GCM+	GCM
ModuleNumber	IC693CMM302	IC693CMM301
Quantity per 90–30 PLC	1, 2, or 3	1
GlobalDataLengths: transmitted received	up to 128 bytes up to 128 bytes each from up to 31 other devices	up to 256 bits total global data, transmitted and received
Number of Other Global Data Devices	31	7
Bus Addresses (SBAs) for Global Data	0–31	16 to 23 only
Memory Types for Global Data	%G, %I, %Q, %AI, %AQ, %R	%G only
Diagnostics LEDs Softwarediagnostics	OK, COMM statusbits, Fault Reports to Series 90–70 PLC	OK, COMM none –
Ability to pass to host PLC a partial global data message only?	yes	no
Host PLC Scan Impact	faster transfers potentially more data	slower transfers restricted maximum data
Host PLC Program	not needed for certain configura- tions	required
Data Default	may default to 0	no option
Series Six Interface	selectable	fixed

A

Attenuation, A-5

B

Baud Rate, Choosing, 4-5

Baud rate

- configuration, 4-4
- selection guidelines, 2-6, 4-5

Bus

- access, A-7
- baud rate, 2-6, 4-5
- cable characteristics, 2-6
- cable types, 2-5
- disconnecting for reconfiguration, 4-1
- electrical interface, A-2
- general transceiver specifications, A-3
- how to disconnect, 2-2
- installation, 2-7
- length, 2-6
- lightning transients, 2-9
- noise, 2-2
- noise, effect on data, A-7
- outdoors, 2-9
- removal, 2-2
- repeaters, using, A-5
- serial data format, A-6
- surge suppression, 2-9
- termination, 2-8
- unspecified cable type, using, A-5
- using other cable types, 2-6
- waveforms, A-4

Bus Address, 4-4, 4-5

Bus scan, 3-5

Bus scan time, 3-7

C

Cable types, 2-5

Catalog number, 1-3

Catalog numbers, inline HHM port,
44A736310-001-R001, 2-10

COMM LED, 1-2

Communications

- loss of, data defaults for, 4-6
- master/slave.example, 1-8, 4-16

- peer-to-peer , example, 1-7, 4-14
- stopped, 3-2, 3-3

Compatibility, 1-3

Computer

- receives global data from GCM+, 3-4
- using to monitor data, 1-5, 4-12, 4-19

Configuration, summary of features and defaults, 4-4

Connector, Hand-held Monitor, 2-10

Control wiring, 2-9

CPU sweep, 3-2, 3-3

CRC checking, A-7

D

Data default, 3-2, 3-3, 4-1, 4-4, 4-6

Data monitoring, 1-5

Device Number, 4-5

Diagnostics

- Fault Reports, 1-4, 5-2
- status bits, 1-4, 5-1

Drop ID, 4-4, 4-7, 5-2

D-shell connector, installing, 2-12

E

Environmental specifications, 1-3

F

Fault clearing, 5-2

Fault Reports, 4-4, 4-7, 5-2

Fiber optics, 2-9

G

GCM module, 1-3

- compared to GCM+, B-1
- configuration example, 4-10
- receives global data from GCM+, 3-4

GCM+ module

- illustration, 1-2
- number per PLC, 1-1
- specifications, 1-3

Genius I/O blocks on bus, 1-1, 1-6

Global data

- amount, 1-4
- length, 4-4, 4-9
- memory types, 1-4, 3-1
- offset, 4-4, 4-8, 4-9
- operation, 3-2, 3-3
- programming for, 1-4
- references, 4-8
- sent during configuration, 4-1

Grounding, 2-9

H

Hand-held Monitor (Genius), compatibility, 1-3

Hand-held Programmer, 1-1
As part of a system, 1-1

Hand-held Monitor, connector, 2-10

Hold last state, 4-1, 4-6

I

I/O blocks on bus, 1-1, 1-6, 3-4

Input data, monitoring with GCM+, 1-6

L

LEDs, 1-2

Logicmaster 90-30 software, compatibility, 1-3

Logicmaster 90-70 software, compatibility, 1-3

M

Memory for global data, in other types of host, 3-4

Module Installation, 2-1

Module location, 1-1

O

Offset for global data, 4-4, 4-8

OK LED, 1-2

P

Power wiring, 2-9

Propagation delays, A-5

R

Racks, installing GCM+ in, 1-1

Reconfiguring the GCM+, 4-1

Remote I/O, emulating with global data, 1-8, 4-16

Removing the Module, 2-2

S

SBA, 4-4, 4-5

Series 90-30 PLC, compatibility, 1-3

Series 90-70 PLC
compatibility, 1-3
monitoring diagnostics from GCM+, 1-4, 5-2
receives global data from GCM+, 3-4

Series Five PLC, 3-4
receives global data from GCM+, 3-4
reference address, 4-4, 4-6

Series Six PLC
compatibility, 1-3
receives global data from GCM+, 3-4
reference address, 4-4, 4-6

Shock, 1-3

Signal wiring, 2-9

Slot Number, 2-1

Slot number, 4-4

Specifications, 1-3

Status bits, 1-4, 4-4, 5-1
meaning, 3-2
memory for, 3-1

Surge suppressors, 2-9

T

Terminal Assembly

- illustration, 1-2
- installation, 2-4
- removal, 2-3, 4-1

Terminating the bus, 2-5

Timing

- bus scan time, 3-6
- busscan/CPU sweep, 3-5
- Device to device response time, 3-7

V

Vibration, 1-3

Voltage attenuation, A-5

W

Wiring guidelines, 2-9